

balco

BT5000W

COMPUTERISED MOTORCYCLE
ROLLER BRAKE TESTER
WITH WEIGHING FACILITY

**Operating Manual and General Information
Version 1.1. UK**

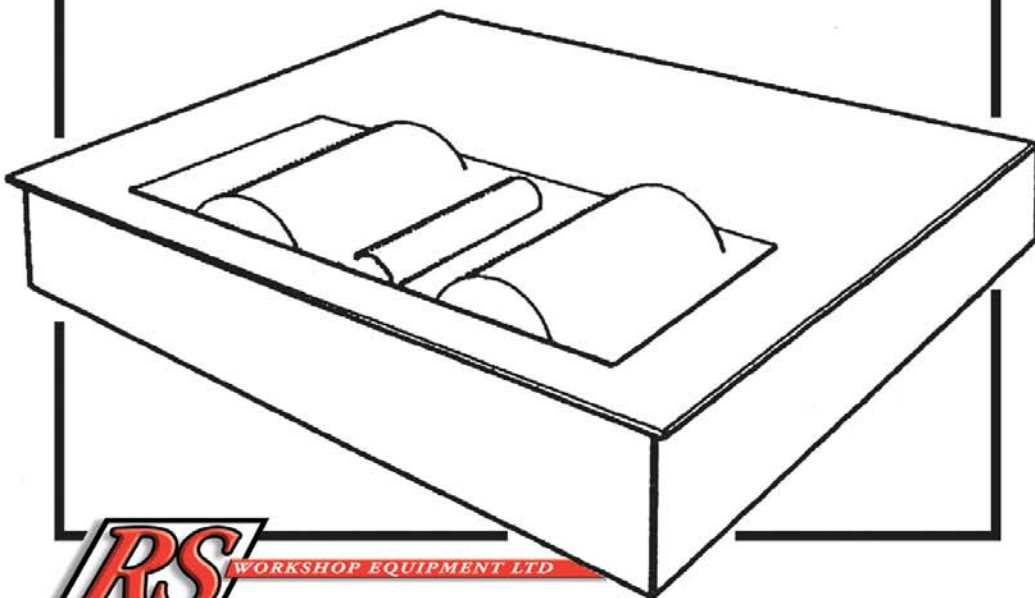

RS WORKSHOP EQUIPMENT LTD

TECHNICAL DATA

BT5000W

- Automatic stop when leaving the rollers
- Automatic slip cut-off (pre-selected between 10 and 25% blocking limit) with pointer stop at max. applied brake force during the test.
- Drive motor 1.5 KW (HP2) 3 phases 380/415 Volt 50 Hz.
- Optional motor 1.5 KW (HP2) 1 phase 220/240 Volt 50 Hz.
- Max. applied axle load 1000 Kg.
- Simple maintenance procedure due to advanced microprocessor system.
- Weight incl.packing 170 Kg.

GENERAL

- The BT5000W brake tester provides you with an easy and precise way of testing braking efficiency as well as the ability to clearly see any faults in the brake-system. By starting brake testing and without applied brake force, the display will indicate defects due to unreleased brakes, please note the rolling resistance from the tyre normally is 5 - 20 KgF depending on tyre, pressure and axle weight. By gradually applying brake force, proportional brake force can then easily be monitored.

- To ensure safety the brake tester will indicate with red and green lights when brake testing can start.

Red light indicates:

Do not apply brake force (wait for green). Green light indicates: Brake tester is ready for applied brake force. Special safety checks performed by the microprocessor system: *No automatic start when wheel is placed in rollerbed. When must be present in roller bed before start button can be accepted. No applied brake force is accepted at start of test. Automatic stop if wheels leave roller bed. Automatic stop at slip point. Automatic stop if brake force exceeds 300 KgF.*

- When power is turned on, the brake tester-system starts a self-test sequence to ensure correct operation of measuring system, safety switches and indication lights. During the self-test sequence the pointer will show which components are currently being tested, after successfully testing all components the pointer will return to zero and red light indicates that the brake tester is ready to use. If the pointer does not return to zero note the value currently pointed at and call authorized service organisation (brake testing cannot be performed).

IMPORTANT: NEVER TURN ON POWER TO THE BRAKE TESTER WHILE STANDING ON ROLLER SET OR WITH MOTORCYCLE PLACED IN THE ROLLERBED.

- **DESIGNED TO FULFIL THE LATEST REQUIREMENTS OF DOT.**

BRAKE TESTING PROCEDURE

BEFORE TESTING

- Turn on power to the brake tester and wait for self-test procedure to be completed.
- Ensure correct tyre pressure and no visible faults on tyre before andly brake test can be attempted.

TEST FRONT WHEEL

• Place front wheel on the clearly marked weighing plate on the roller bed. The wheel indicator display will now display: 1 (one) to indicate test of the first wheel and the Kg display will show the actual weight of the wheel. When the readings are stable, press the memory button. Please note the rider's behaviour has influence on stable readout. Both mentioned displays will keep the values under the following brake testing.

- Place front wheel in roller bed and release brakes.
- Press the green start button for forward testing, now the rollers will start rotating, use both hands to stabilise front wheel in roller bed. When roller speed is stabilized after approx. 2-3 seconds, the green light will indicate brake tester is running correctly.
- Applying no brake force the display will now show the rolling resistance. (i.e. a small constant force, if this erratic or high, check for related problems, i.e. run-out sticking brakes etc.)
- To maintain stability in the roller bed apply medium brake force at the rear wheel first, then apply gradual medium brake force at the front wheel. With a correct operating brake system the pointer will indicate a stable value. Run-out faults in the brake system will show an oscillating pointer.
- Slowly increase brake force until the rollers automatically stop. (red light is turned on). The pointer will now hold the maximum applied brake force during test.
- Now the brake force can be memorised simply as follows: keep the wheel in the roller bed and press the memory button.
- Further testing on front wheel can be performed by releasing brake and pressing the start button again as described above. (This last brake force overrides the previous).

TEST REAR WHEEL

• Place the rear wheel on the clearly marked weighing plate on the roller bed. The wheel indicator will now display 2 (two) to indicate test of second wheel and the Kg display will show the actual weight of the wheel. When the readings are stable, press the memory button. Please note that the rider's behaviour has influence on stable read-out. Both mentioned displays will keep the values under the following brake testing.

- Place the rear wheel in roller bed and release brakes.
- Press the green start button for forward testing.

Now the rollers will start rotating. When the roller speed is stabilised after approx. 2-3 seconds, the green light will indicate the rollers are running correctly.

- Applying no brake force the display will now show the rolling resistance (as described above).
- To maintain stability in the roller bed apply medium brake force at front wheel first. Then apply gradual medium brake force at rear wheel. With a correctly operating brake system it will indicate a stable value. Run-out faults in the brake system will show oscillating pointer.
- Slowly increase brake force until the rollers automatically stop (red light is turned on). The pointer will now hold the maximum applied brake force during the test.

- Now the brake force can be memorised simply as follows: keep the wheel in the roller bed and press the memory button.
- Further testing on the rear wheel can be performed by releasing brake and pressing start button again as described above. (The last memorised brake force overrides the prior).
- After testing and store of data, the rear wheel must now leave the roller bed and the calculated values be present. Indicator display will display will display a: 1 for total. The weight display will display the sum of front and rear weight i.e 645Kg. The first diff display will show the front wheel brake force in percentage of the total weight i.e. 36%.
- All values will be present for a period of 10 minutes or until the next brake test is started.

PRINTING

- If your BT5000W Brake Tester includes the printer option, simply press the button on the remote control and all tested/memorised values will appear on paper.

TEST SIDE CAR WHEEL

- Place the wheel in roller bed and release brakes. Depending on type of installation (i.e. position of unit), it might be necessary to reserve the motorcycle to place the sidecar wheel on roller bed.
- Press the green start button for forward/reverse testing (the test procedure is the same for both forward and reverse rotation of roller). Now the rollers will start rotating. When the roller-speed is stabilised after approx. 2-3 seconds, the green light is to indicate brake tester is running correctly.
- Applying no brake force the display will now show the rolling resistance (as described above).
- To maintain stability in the roller bed apply medium brake force at motorcycle wheel first. Then apply gradual medium brake force at sidecar wheel. With a correctly operating brake system will show an oscillating pointer.
- Slowly increase brake force until the rollers automatically stop (red light is turned on). The pointer will now hold the maximum applied brake force during test.
- Further testing on sidecar wheel can be performed by releasing the brake and pressing start button again (as described above).

SERVICE ROUTINE

- Always keep the roller bed clean and free of water. Make sure that the drain or sump in the pit is in good order. If by accident water gets in the roller bed **NEVER TURN ON THE MAIN POWER**. Contact our service organisation.
- To comply with the requirements of the V.I. calibration of the brake tester must be carried out every 6 months.
- At the power-up time the brake tester performs a safety check procedure where the following items are tested: No wheel in roller bed, no buttons are activated, no rotation of roller and no force applied on the roller. During this test the display will indicate some brake values i.e. 0-50-100... and return to zero when finished. Also the lamps are tested. Please observe that all lamps have been both on and off and at the end only the red lamp is on. In the event of any problems with your BT5000W Motorcycle Brake Tester, please contact:

RS WORKSHOP EQUIPMENT LTD.
UNIT 28, BARNWELL MANOR INDUSTRIAL ESTATE, BARNWELL,
PETERBOROUGH, CAMBS. PE8 5PL
TEL: 01832 741007 FAX: 01832 741008
 Or your local authorised BALCO distributor.

TESTER CALIBRATION

Before Calibration

- Turn off the power to the brake tester.
- Check that all the required tools are available: *Hex-key set in mm. Metric type socket set and spanners. Special isolated screwdriver for trimmer pot.meter. This manual. Test-jig and two verified 10 Kg weights. Jig holder (might be permanently mounted on gear motor).*
- Remove the cover plate from roller bed.
- Open the cabinet.

TEST JIG

- The test-jig is supplied with the two 10 Kg weight. There are two positions to hang the 10 Kg weight. With no weight on the jig, the instrument must be zero-adjusted to compensated the neutral jig force.

With 10 Kg mounted in Pos. 1 the display will indicate 30 KgF+/-3Kg.

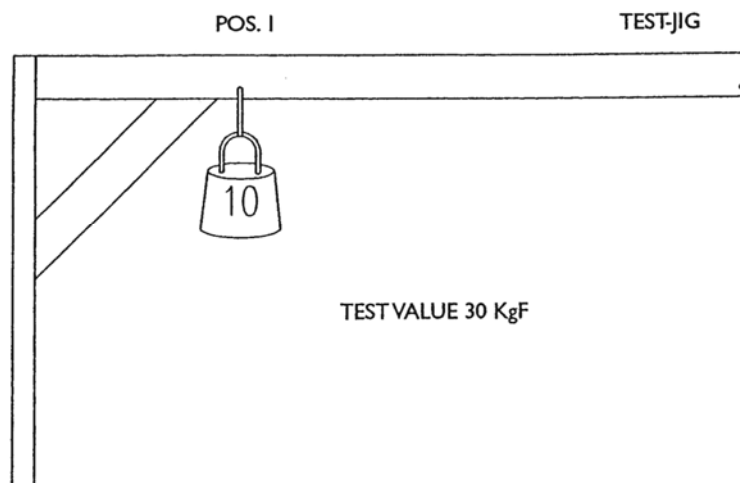

With 10 Kg mounted in Pos. 2 the display will indicate 100 KgF+/-3KgF.

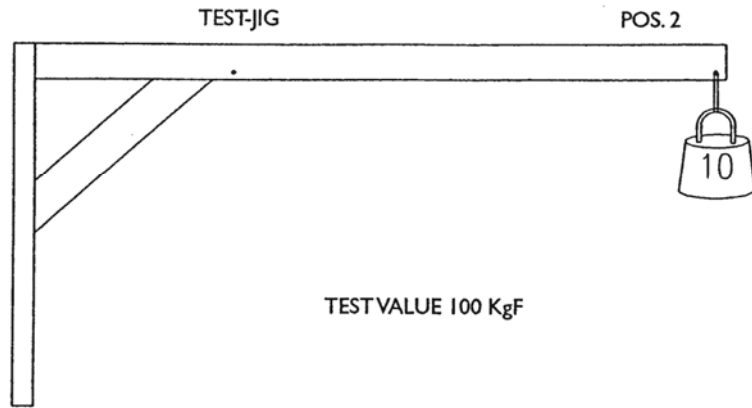

With 20 Kg mounted in Pos. 2 the display will indicate 200 KgF+/-6KgF.

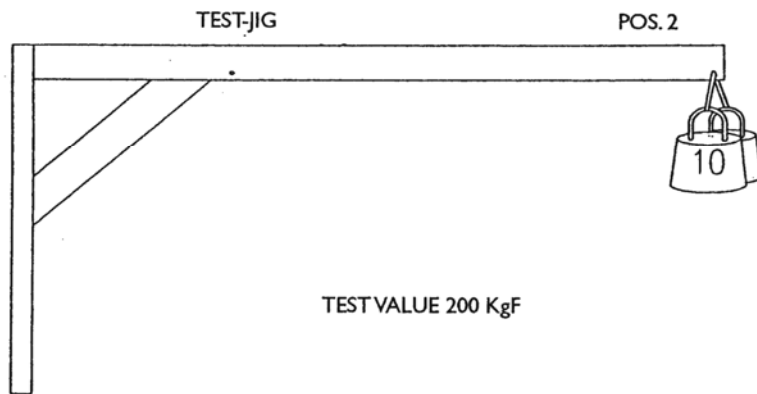

CALIBRATION PROCEDURE

- Turn on power to the brake tester and wait for self-test procedure to be completed.
- Put the Dip-Switch 1 on the computer board in pos. **ON**. The display will now indicate any force applied on the load cell (Gear motor Support).
- Mount the Test-Jig on the gear-motor parallel with the normal drive direction of motorcycle testing.
- Adjust the zero after placing the jig (No weight must be mounted).
- Place 10 Kg in Pos. 1 and verify that the display indicates 30 KgF \pm 3. If outside this tolerance then adjust gain, remove the weight and check the zero.
- Place 10 Kg in Pos. 2 and verify that the display indicates 100 KgF \pm 3. If outside this tolerance then adjust gain, remove the weight and check the zero.
- Place 20 Kg in Pos. 2 and verify that the display indicates 200 KgF \pm 6. If outside this tolerance then adjust gain, remove the weight and check the zero.
- Check again the 30, 100 and 200 value if any adjustment has been necessary.
- Remove the Test-jig.
- Mount the cover plate and check that zero is still correct.
- Turn off the power.
- Put switch 1 back in pos. **OFF** for normal operation.
- Close the cabinet.
- Turn on the power and check that operation is normal.

CALIBRATION WEIGHING

Before Calibration

- Turn off the power to the brake tester.
- Check that all the required tools are available:
Hex-key set in mm.
Metric type socket set and spanners.
Special isolated screwdriver for trimmer pot. meter.
This manual.
Test-jig and two verified 10 Kg weights.
- Remove the cover plate from roller bed.
- Open the cabinet.

TEST JIG

- The test-jig is supplied with the two 10 Kg weight. There are two positions to hang the 10 Kg weight.
- With no weight on the jig, the instrument must be zero-adjusted to compensate the neutral jig force.

With 10 Kg mounted in Pos.2 the display will indicate 100 Kg (+/- 3 Kg).

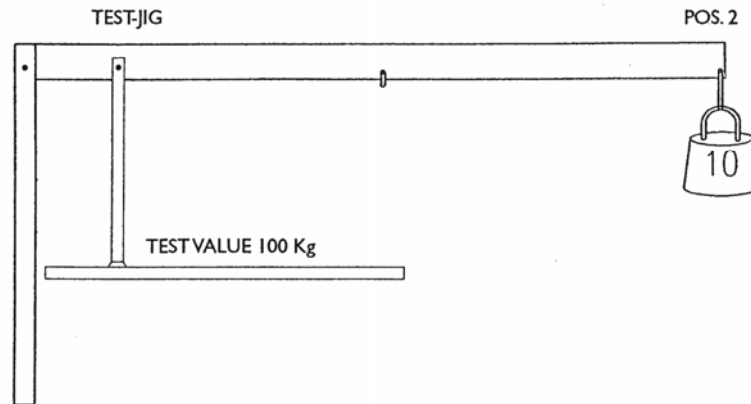

With 20 Kg mounted in Pos.2 the display will indicate 200 Kg (+/- 6 Kg).

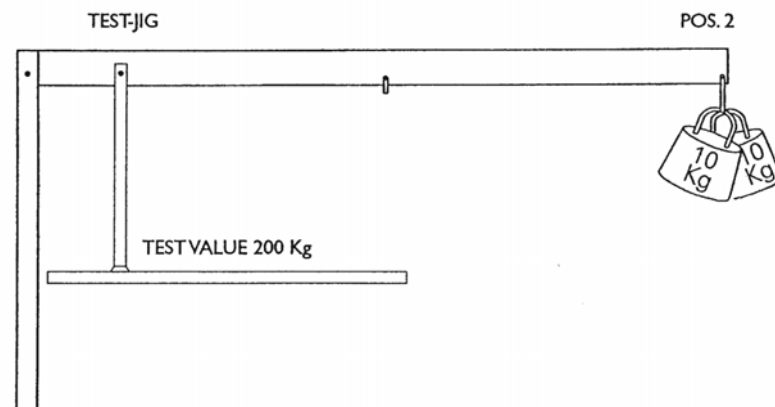

With 30 Kg mounted in pos.2 the display will indicate 300 Kg (+/-6 Kg).

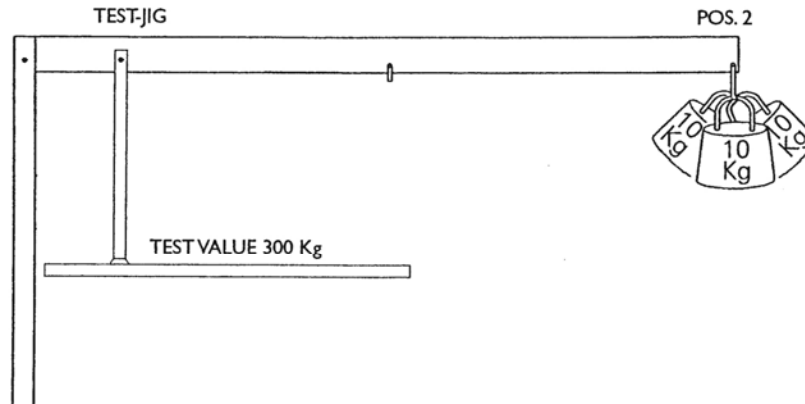

If the brake tester indicate values outside of this tolerance, you must adjust the gain trimmer on the I/O board in the cabinet. After many gain adjustments you must check the zero adjustment.

- Designed to fulfil the specification and requirement of DOT. (50, 100, 200 and 300 Kg are required by DOT).

CALIBRATE PROCEDURE WEIGHING

- Turn on power to the brake tester and wait for self-test procedure to be completed.
- Put the Dip-Switch 1 on the computer board in pos. ON. The display will now indicate any force applied on the load cell.
- Mount the Test-jig.
- Adjust the zero after placing the jig (NO weight must be mounted).
- Place 10 Kg in Pos. 1 and verify that the display indicates 50 Kg +/-3. If outside this tolerance then adjust gain, remove the weight and check the zero.
- Place 10 Kg in Pos. 2 and verify that the display indicates 100 Kg +/-3. If outside this tolerance then adjust gain, remove the weight and check the zero.
- Place 20 Kg in Pos. 2 and verify that the display indicates 200 Kg +/-3. If outside this tolerance then adjust gain, remove the weight and check the zero.
- Place 30 Kg in Pos. 2 and verify that the display indicates 300 Kg +/-3. If outside the tolerance then adjust gain, remove the weight and check the zero.
- Check again 50, 100, 200 and 300 value if any adjustment had been necessary.
- Remove the Test-jig.
- Adjust the zero after removing the jig.
- Mount the cover plate and check that the zero is still correct.
- Turn OFF the power.
- Put switch 1 back in Pos. OFF for normal operation.
- Close the cabinet.
- Turn on the power and check normal operation.

INSTALLATION

The roller bed is mounted with four eyebolts when shipped. Please use all four when lifting the roller bed, and use two 50mm shorter chains at motor side. (left on this drawing) then the two others to keep level when lifting down in the pit.

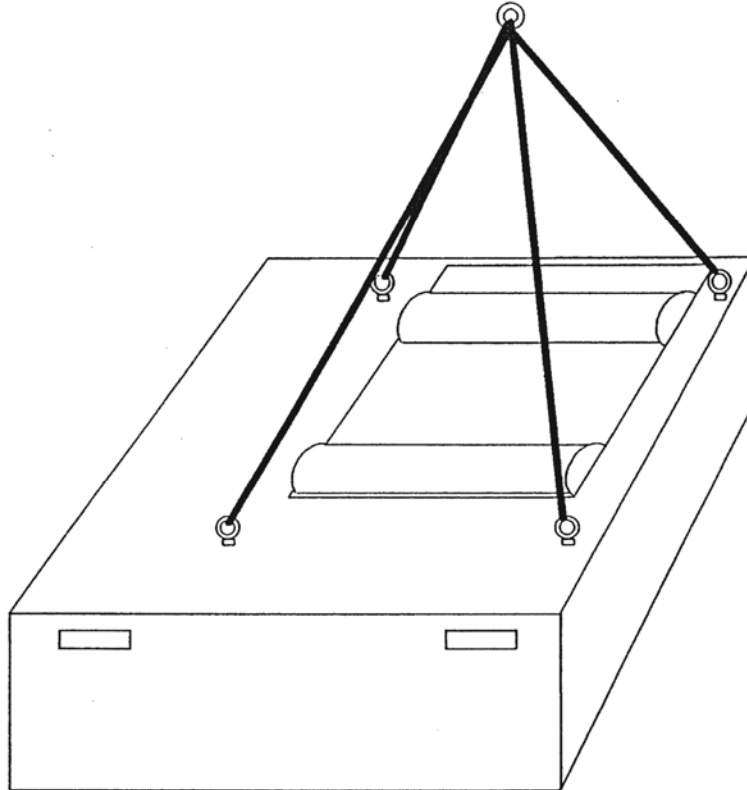

Make sure that the frame is standing stable and is safely fixed at the end side of the pit.

Make sure that the frame is standing stable and is safely fixed at the end side of the pit.

POWER DIAGRAM

The brake tester BT5000 can be supplied for either 3 phase or single phase main supply.

The single phase model has the following diagram for the roller bed:

The motor is 1.5kW and needs to be fused by 16 Amp. slow acting.

The 3 phase model has the following diagram for the roller bed:

The motor is 1.5kW and needs to be fused by 10 Amp. slow acting.

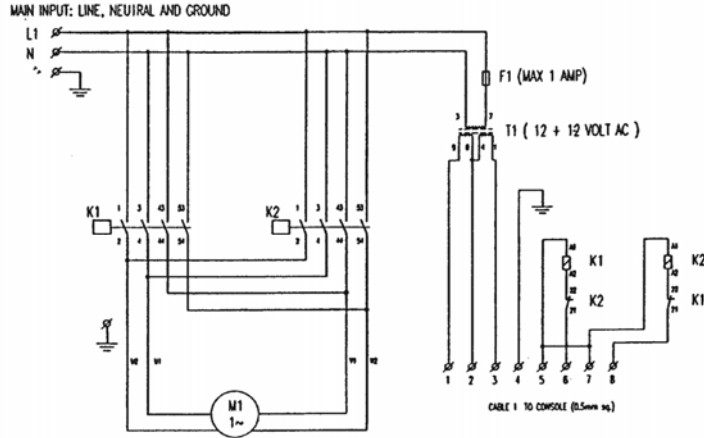

The motor is 1.5kW and needs to be fused by 16 Amp. slow acting.

The 3 phase model has the following diagram for the roller bed:

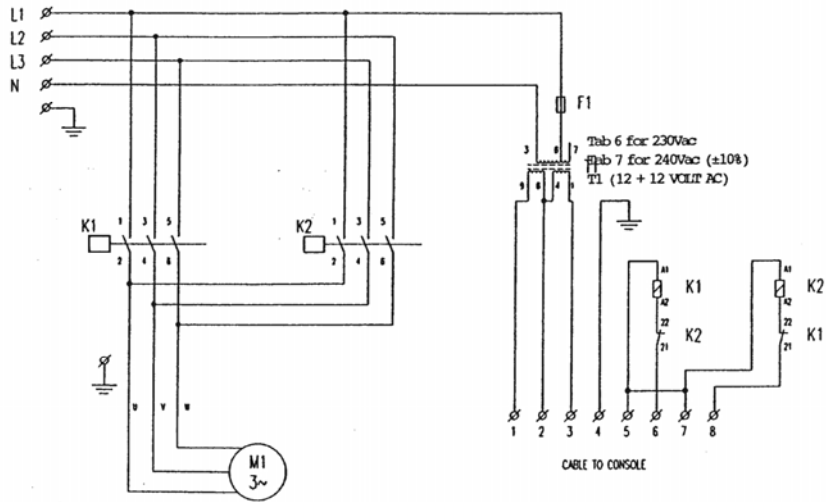

The motor is 1.5kW and needs to be fused by 10 Amp. slow acting.