



# TECHANGLE®

ELECTRONIC  
TORQUE-ANGLE  
WRENCH



PAGE	LANGUAGE
1	English
22	Português
46	Deutsch
70	Nederlands
94	Italiano

# **IMPORTANT SAFETY INSTRUCTIONS**



## **WARNING *Risk of flying particles.***

Over-torquing can cause breakage. Force against flex stops on flex head can cause head breakage. An out of calibration angle wrench can cause part or tool breakage. Broken hand tools, sockets or accessories can cause injury. Excess force can cause crowfoot or flare nut wrench slippage.

- Read **this manual completely** before using ELECTRONIC WRENCH.
- To insure accuracy, work must not move in angle mode.
- For personal safety and to avoid wrench damage, follow good professional tool and fastener installation practices.
- Periodic recalibration is necessary to maintain accuracy.
- Wear safety goggles, user and bystanders.**
- Be sure all components, including all adaptors, extensions, drivers and sockets are rated to match or exceed torque being applied.
- Observe all equipment, system and manufacturer's warnings, cautions and procedures when using this wrench.
- Use correct size socket for fastener.
- Do not use sockets showing wear or cracks.
- Replace fasteners with rounded corners.
- To avoid damaging wrench:** Never use wrench with power off. Always turn ON wrench so applied torque is being measured.
  - Do not press **POWER**  while torque is applied or while wrench is in motion.
  - Never use this wrench to break fasteners loose.
  - Do not use extensions, such as a pipe, on handle of wrench.
  - Check that wrench capacity matches or exceeds each application before proceeding.
  - Verify calibration if dropped.
- Make sure ratchet direction lever is fully engaged in correct position.
- Verify calibration of wrench if you know or suspect its capacity has been exceeded.
- Do not force head of flex head drives against stops.
- Always pull - do not push - on wrench handle and adjust your stance to prevent a possible fall should something give.
- Do not attempt to recharge Alkaline cells.
- Store wrench in dry place.
- Remove batteries when storing wrench used for periods longer than 3 months.



## **WARNING *Electrical Shock Hazard.***

Electrical shock can cause injury. Plastic handle is not insulated. Do not use on live electrical circuits.

## **SAVE THESE INSTRUCTIONS**

### **Disclaimer**

Operation of TechAngle® Wrench is not warranted in a EU member state if operating instructions are not in that State's language. Contact Snap-on if a translation is needed.

# Specifications

## Head Type

- Square drive 72 or 80 teeth, sealed flex

## Display

- DISPLAY TYPE: Dot Matrix LCD (192 x 65 Resolution)
- VIEWING DIRECTION: 6:00
- BACKLIGHT: WHITE (LED)

## Sealed Button Pad



**POWER** - ON/OFF and torque and angle re-zero



**ENTER** - measurement mode select and menu entry



**UP** – increments torque and angle settings and menu navigation



**DOWN** - decrements torque and angle settings and menu navigation



**UNITS** - units select (ft-lbs, in-lbs, Nm, Kgm, Kg-cm, dNm) and enter PSET (preset) menu



**LCD BACKLIGHT** – Illuminates all screens and last peak torque or angle recall

## Functions

- Set - torque or angle target
- Track - real time display of torque or accumulated angular rotation with progress lights
- Peak Hold – 10 sec. flashing of peak torque or alternating peak torque/angle on release of torque
- Peak Recall - display last peak torque or peak torque/angle on button press
- Memory - display of last 50 peak torque or peak torque/angle readings

## Accuracy

- Temperature: @ 22°C (72°F)
- Angle:  $\pm 1\%$  of reading  $\pm 1^\circ$  @ angular velocity  $> 10^\circ/\text{sec} < 180^\circ/\text{sec} \pm 1^\circ$  of test fixture  
CW CCW
- Torque: 

{	$\pm 2\%$	$\pm 3\%$	of reading, 20% to 100% of full scale
	$\pm 4\%$	$\pm 6\%$	of reading, 10% to 19% of full scale
	$\pm 8\%$	$\pm 10\%$	of reading, 5% to 9% of full scale

  
(unflexed)

## Dimensions: Length / Weight

Model	Length	Weight
ATECH1FR240B	16.4 in.	1.9 lbs.
ATECH2FR100B	17.9 in.	2.3 lbs.
ATECH3FR250B	26.6 in.	3.7 lbs.

## Preset Range

- ANGLE: 0 to 360° CW or CCW (Display Resolution 1°)
- TORQUE: (Display Range and Resolution as shown below)

Model	Square Drive	ft-lb	in-lbs	Nm	Kgm	kg-cm	dNm	overload (ft-lb)
ATECH1FR240B	¼ in.	1.00-20.00	12.0-240.0	1.36-27.12	N/A	13.8-276.5	13.6-271.2	25
ATECH2FR100B	⅜ in.	5.0-100.0	60-1200	6.8-135.6	N/A	69-1383	68-1356	125
ATECH3FR250B	½ in.	12.5-250.0	150-3000	16.9-339.0	1.73-34.56	N/A	N/A	312

**Operating Temperature:** 0°F to 130°F (-18°C to 54°C)

**Storage Temperature:** 0°F to 130°F (-18°C to 54°C)

**Measurement Drift:** ANGLE: -0.12 Angular Degrees per Degree C  
TORQUE: +0.01% of reading per Degree C

**Humidity:** Up to 90% non-condensing

**Battery:** Three "AA" Alkaline Cells, up to 80 hours continuous operation

**Default Auto Shut-off:** After 2 minutes idle – (Adjustable, see Advanced Settings)

# User Instructions

## • Basic Functions (Quick Start)

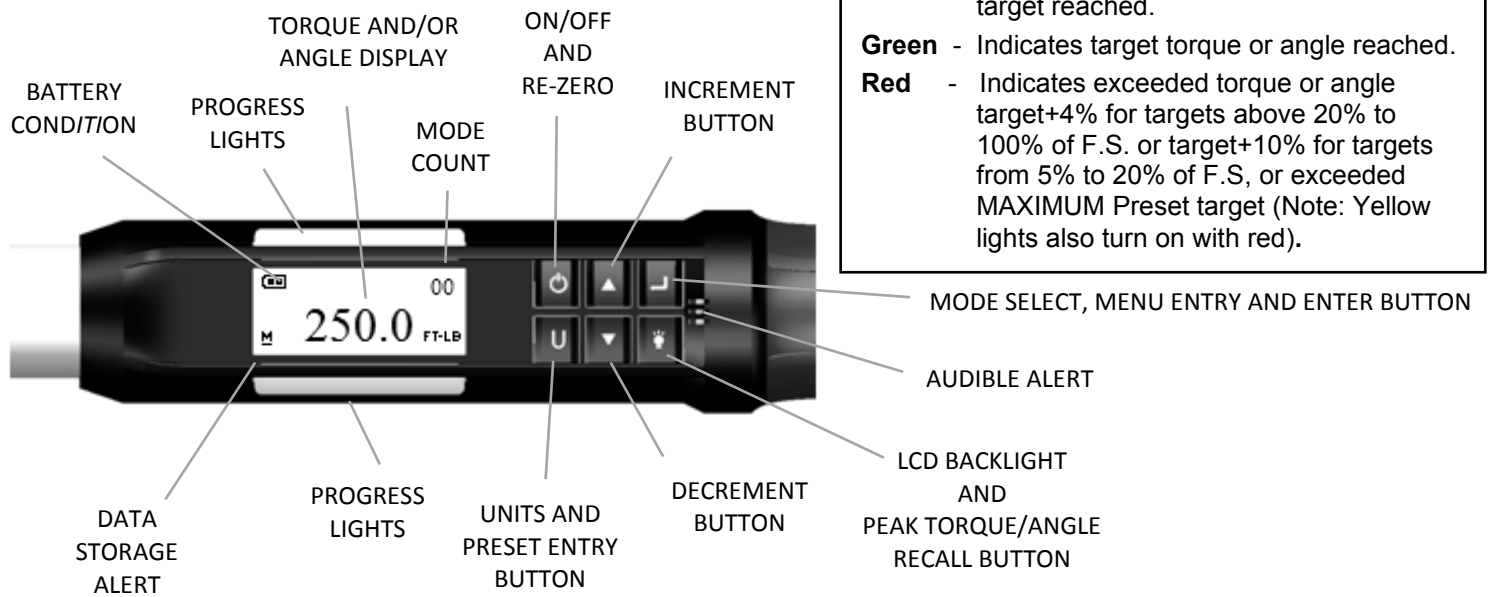

Figure 1

Install three fresh "AA" cells into wrench handle.

### Wrench Power On Sequence

*Note: Do not turn on wrench while torque is applied, otherwise torque zero offset will be incorrect and wrench will indicate a torque reading when torque is released. If this occurs, re-zero wrench by momentarily pressing **POWER** button while wrench is on a stable surface with no torque applied.*

1. Turn On Wrench.

Momentarily press **POWER** button. Snap-on logo is displayed followed by torque re-zeroing screen. If previous measurement was angle measurement, then angle re-zeroing screen follows the torque zeroing screen. After re-zeroing, the target torque or target angle screen is displayed depending on previous measurement mode.

2. Select Measurement Mode.

Toggle between target TORQUE and ANGLE screens by repeatedly pressing **ENTER** button.

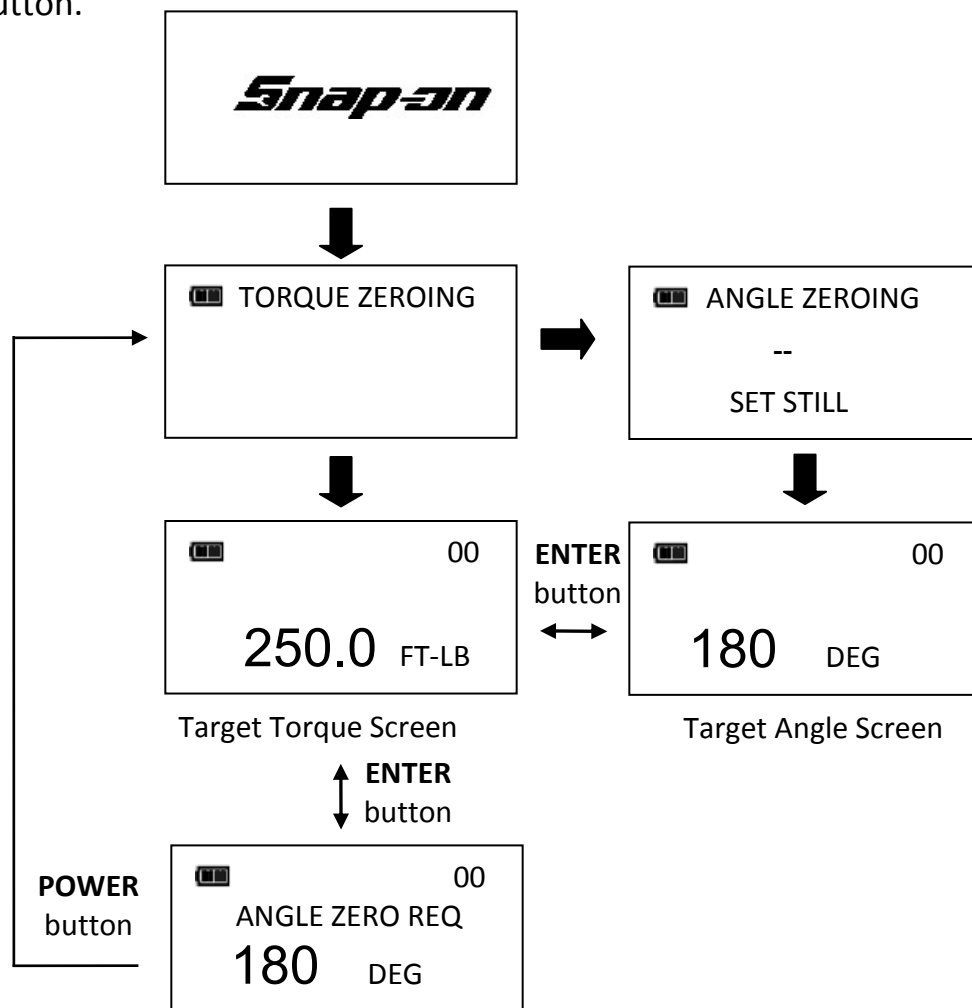



*Note: If wrench is powered up in torque only measurement mode, angle is not zeroed until mode is changed to angle measurement mode, at which time torque and angle zeroing begins automatically after 2 seconds. Wrench should be placed on a stable surface with no torque applied.*

*Note: Pressing **ENTER**  button while angle is zeroing will abort zeroing function to allow user to select another measurement mode.*

## **Torque Mode**

### 1. Set Target.

Use **UP** /**DOWN**  buttons to change TORQUE target value.





### 2. Select Units of Measure.

Repeatedly press **UNITS**  button while on target TORQUE screen until desired units are displayed.

### 3. Apply TORQUE.

Grasp center of handle, (DO NOT pull on battery end-cap) and slowly apply torque to fastener until progress lights display green and a ½ second audible alert and handle vibration alerts user to stop.

### 4. Release TORQUE.

Note peak TORQUE reading flashing on LCD display for 10 seconds. Pressing **BACKLIGHT**  button while peak torque is flashing will continue to display value until button is released. Momentarily press **UP** /**DOWN** , **ENTER**  or **UNITS**  button to immediately return to target TORQUE screen. Reapplying TORQUE will immediately start another TORQUE measurement cycle.

### 5. Recall Peak TORQUE Reading

To recall last peak TORQUE measurement, press and hold **BACKLIGHT**  button for approximately 3 seconds. Peak TORQUE will flash for 10 seconds.



## **Angle Mode**

*Note: Do not apply torque while torque and angle are zeroing otherwise torque zero offset will be incorrect and wrench will indicate an angle reading when torque is released. If this occurs, re-zero wrench by momentarily pressing **POWER**  button with wrench setting on a stable surface with no torque applied.*

### 1. Angle Zero

If "ANGLE ZERO REQ" message is displayed, wait 2 seconds for automatic angle zeroing sequence before applying torque or moving wrench.





### 2. Set target.

Use **UP** /**DOWN**  buttons to change target ANGLE value.

### 3. Apply Torque and Rotate Wrench.

Grasp center of handle, (DO NOT pull on battery end-cap) and slowly apply torque to fastener and rotate wrench at a moderate consistent speed until progress lights display green and a ½ second audible alert and handle vibration alerts user to stop.

### 4. Release torque.

Note alternating peak TORQUE and ANGLE readings flashing on LCD display for 10 seconds. Pressing **BACKLIGHT**  button while peak angle is flashing will continue to display value until button is released. Momentarily press **UP** /**DOWN** , **ENTER**  or **UNITS**  button to immediately return to target ANGLE screen. Reapplying torque (ratcheting) before target screen is displayed will continue ANGLE accumulation as wrench is rotated.

### 5. Recall Peak ANGLE Reading

To recall last peak ANGLE measurement, press and hold **BACKLIGHT**  button for approximately 3 seconds. Peak TORQUE and ANGLE will be displayed alternately for 10 seconds.

## Mode Cycle Count

TechAngle® mode cycle count feature is used to indicate number of times wrench has reached target torque in torque measurement mode or target angle in angle measurement mode.

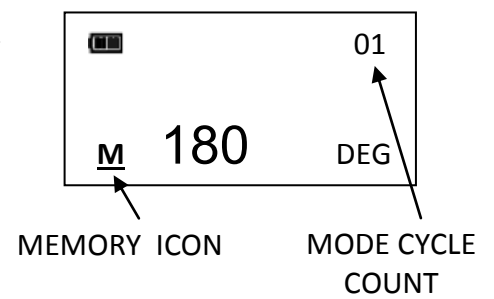





## Torque and Angle Mode Cycle Counting

1. Numerical counter located in top right of target torque or target angle screen will increment after each torque or angle cycle if applied torque or angle has reached target value.
2. When toggling between torque mode or angle mode using **ENTER**  button or if target is changed, numerical counter will reset back to 00. Counter WILL NOT reset when re-zeroing, on menu entry/exit or power down.
3. Memory icon will turn on indicating at least one torque or angle cycle data has been stored in memory.

## Main Menu

Main menu displays wrench operational information.

1. From target torque or angle screen, press and hold **ENTER**  button for 3 seconds.
2. Use **UP** /**DOWN**  buttons to highlight menu selection then press **ENTER**  button.





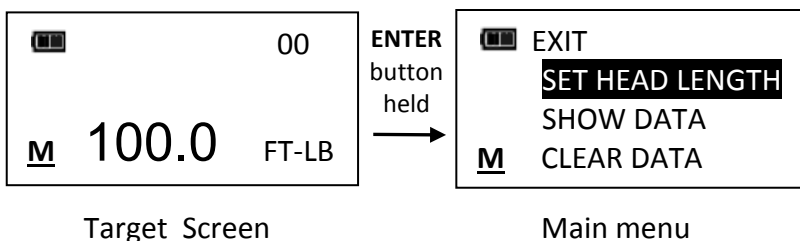





Menu Selections:

- EXIT - Exits Main menu and returns to target screen.
  - SET HEAD LENGTH - Displays wrench head length entry screen.
  - SHOW DATA - Displays stored torque and angle data.
  - CLEAR DATA - Clears stored torque and angle data.
  - CYCLE COUNT - Displays torque/angle cycle count screen.
  - SETTINGS - Displays advanced settings menu (see Advanced Settings Section).
  - CONFIGURE - Displays advanced configuration menu (see Advanced Configuration Section).
3. To exit Main menu and return to target torque or angle screen, press **ENTER**  button while **EXIT** menu selection is highlighted.



## Setting Head Length

*Note: If an adapter or extension is added to wrench, length of adapter/extension being used can be entered to correct for a different length than head used to calibrate wrench without requiring re-calibration.*

1. To enter a head length, from target torque or angle screen, press and hold **ENTER**  button for 3 seconds.
2. With **SET HEAD LENGTH** menu selection highlighted, momentarily press **ENTER**  button.
3. Set Head Length screen is displayed next. Default head length is length of head at calibration. Use **UP** /**DOWN**  buttons to increment/decrement head length.
4. Pressing and holding **UP** /**DOWN**  buttons will progressively increment/decrement value faster. Pressing **UP**  and **DOWN**  buttons simultaneously will reset head length to zero.
5. Default units of length is in inches. Press **UNITS**  button to change to millimeters.
6. Pressing **ENTER**  button after length is set returns to main menu. If length is changed from default, "OFFSET IN USE" message will be displayed on target screen.

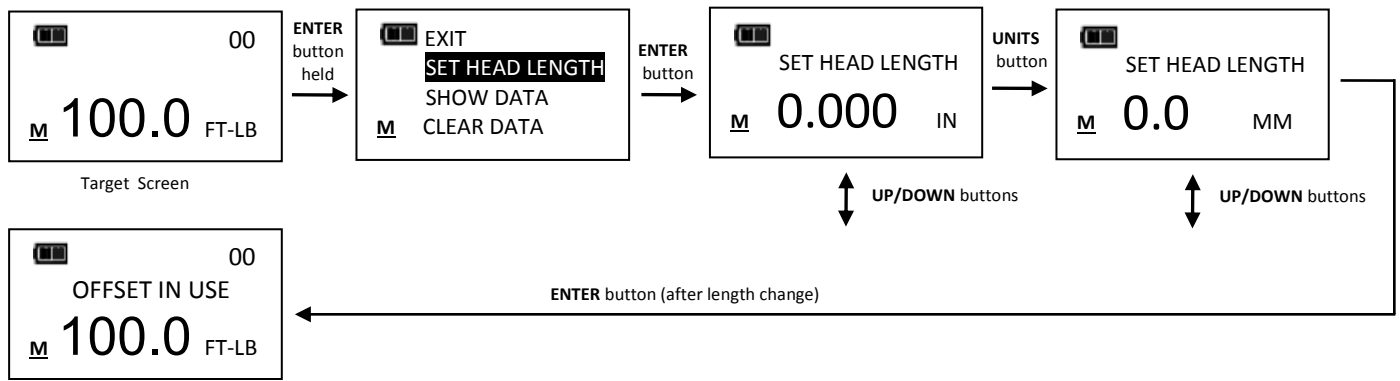

Note: Head length entered is offset length measured from center of drive to center of fastener.

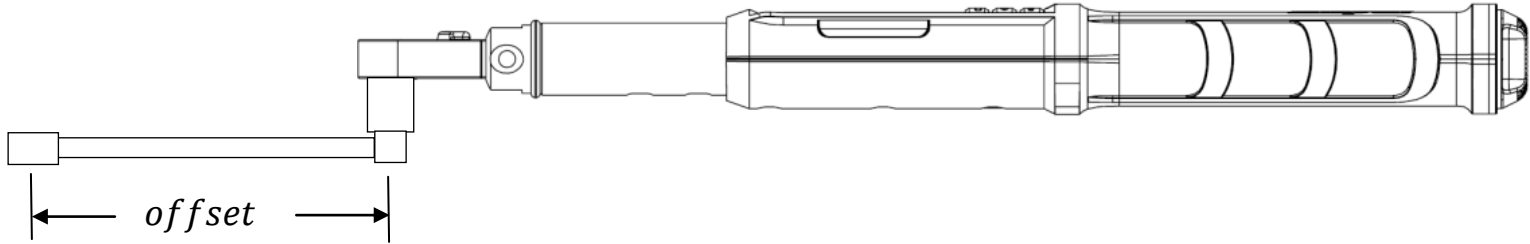

### Use of Negative Offsets

Note: Enter a negative value for offset when used in reverse direction.

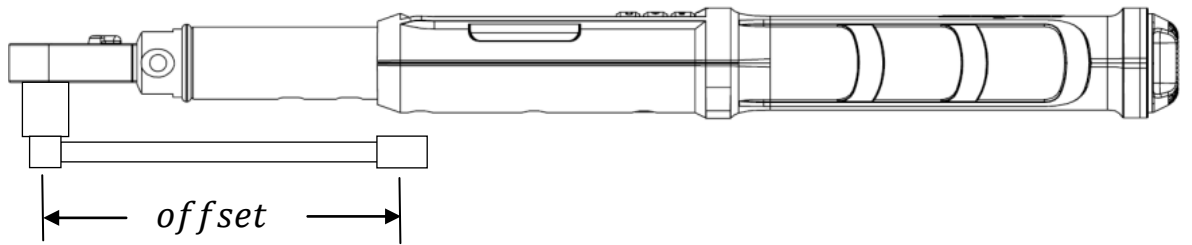

When length of an offset is negative, maximum fastener target is limited by following formulas:

240 in-lb wrench:  
Maximum Target Torque =  
 $\text{offset} * 24 + 240$

Offset	Max Target
-1"	216 in-lb
-2"	192 in-lb
-3"	168 in-lb
-4"	144 in-lb

100 ft-lb wrench:  
Maximum Target Torque =  
 $\text{offset} * 8 + 100$

Offset	Max Target
-1"	92 ft-lb
-2"	84 ft-lb
-3"	76 ft-lb
-4"	68 ft-lb

250 ft-lb wrench:  
Maximum Target Torque =  
 $\text{offset} * 12 + 250$

Offset	Max Target
-1"	238 ft-lb
-2"	226 ft-lb
-3"	214 ft-lb
-4"	202 ft-lb

Note: When using a negative offset, entering a target torque greater than maximum values above may cause an overtorque error before reaching fastener target torque and possibly damage wrench.

### Viewing Stored Torque and Angle Data

Torque data is stored in memory after each torque cycle if applied torque has reached target value. Torque and angle data is stored in memory after each angle cycle if applied angle has reached target value. Memory Indicator is displayed when data is stored in non-volatile memory.

- To view stored torque and angle data, from target torque or angle screen, press and hold **ENTER** button for 3 seconds.
- Highlight **SHOW DATA** menu selection by pressing **UP** /**DOWN** buttons then press **ENTER** button to display Show Data screen.

- In Show Data screen, scroll through each stored data record by pressing **UP** ▲ / **DOWN** ▼ buttons.

Example: 02 = Show Data List Counter: TQ = Peak torque value

01 = Show Data List Counter: TQ = Peak torque value: ANG = Peak angle value

- Pressing **ENTER** ↵ button while on Show Data screen returns to main menu.

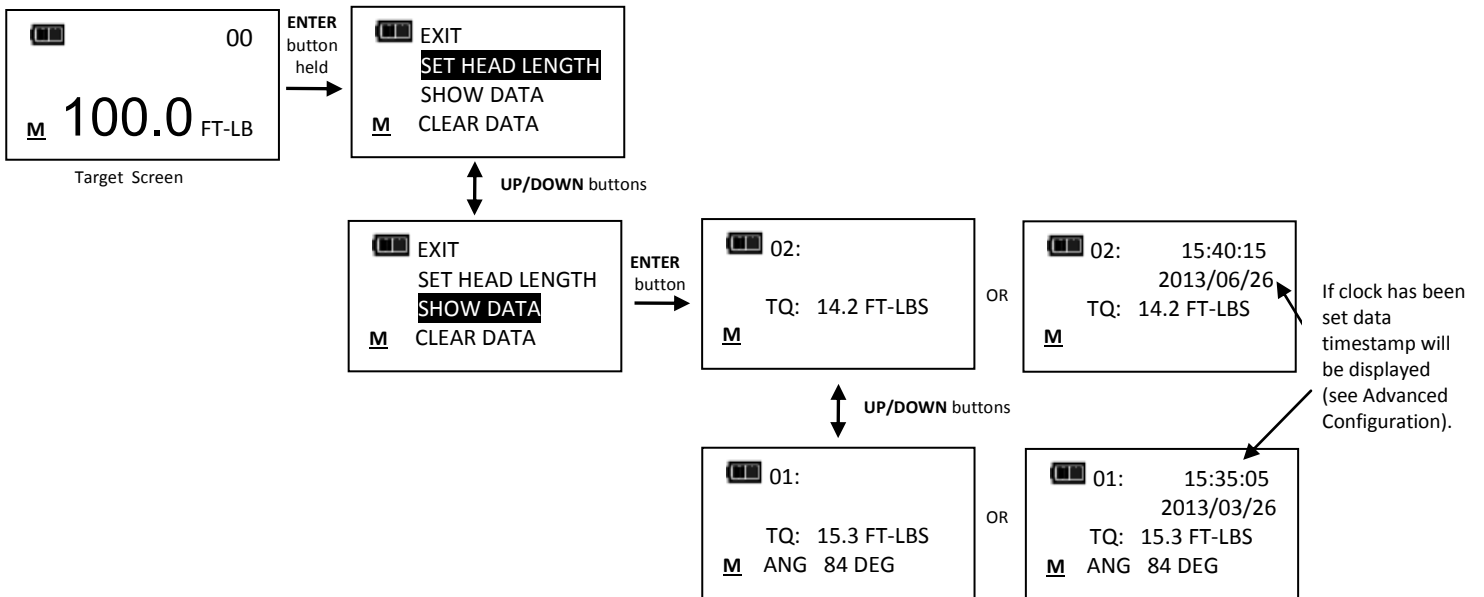

*Note: A maximum of 50 data records can be stored in memory. Memory full icon will be displayed when full. New data will replace oldest record until memory is cleared.*

### Deleting Stored Torque and Angle Data

- From target torque or angle screen, press and hold **ENTER** ↵ button for 3 seconds.
- Highlight **CLEAR DATA** menu selection using **UP** ▲ / **DOWN** ▼ buttons then press **ENTER** ↵ button to display CLEAR ALL DATA screen.
- In CLEAR ALL DATA screen, highlight **YES** menu selection to delete all stored data, or **NO** menu selection to exit without deleting data.
- Press **ENTER** ↵ button after making selection.

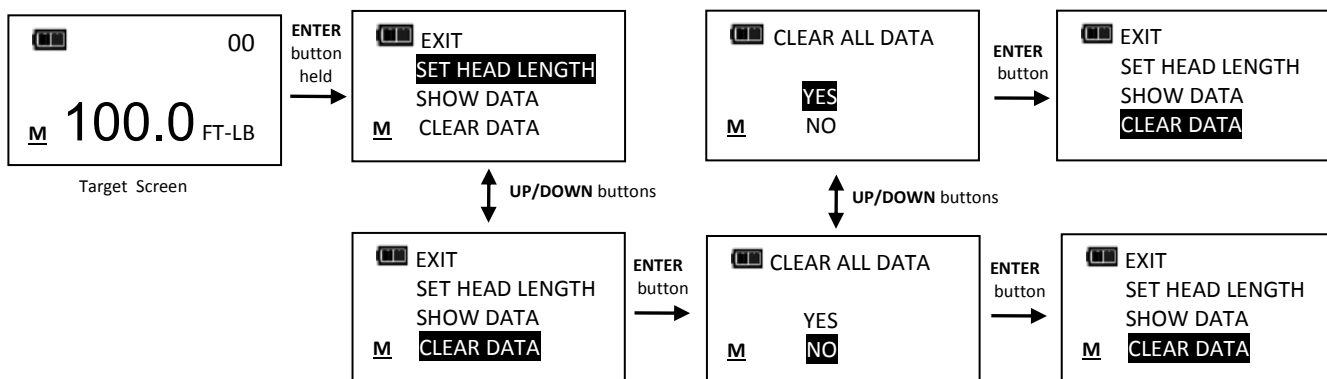

### Viewing and Clearing Wrench Cycle Counter

Each time torque or angle target is reached, wrench cycle counter is incremented. Maximum cycle count is 999999.

- From target torque or angle screen, press and hold **ENTER** ↵ button for 3 seconds.
- Highlight **CYCLE COUNT** menu selection using **UP** ▲ / **DOWN** ▼ buttons.
- Press **ENTER** ↵ button to display CYCLES screen.
- To exit CYCLE COUNT screen without clearing count, press **ENTER** ↵ button while **EXIT** menu selection is highlighted.
- To reset wrench cycle count to 0, highlight **CLEAR** menu selection then press **ENTER** ↵ button.
- EXIT** menu selection is automatically highlighted after count is cleared. Press **ENTER** ↵ button to return to main menu.



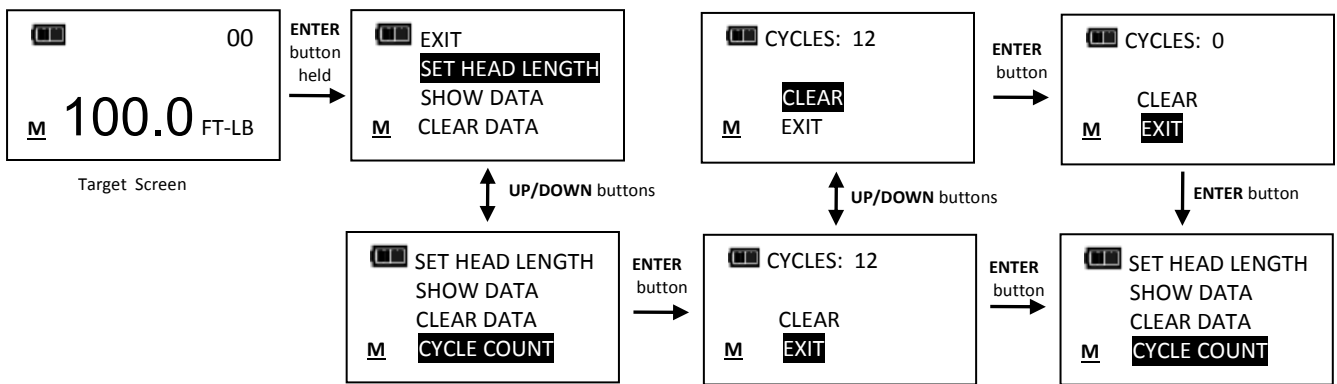



## Target Presets (PSET)

PSET function gives user ability to configure 10 preset target torque or target angle settings, each with a minimum (target), maximum (over range) and batch count value. PSETs are stored in non-volatile memory so that they are retained while power is off.



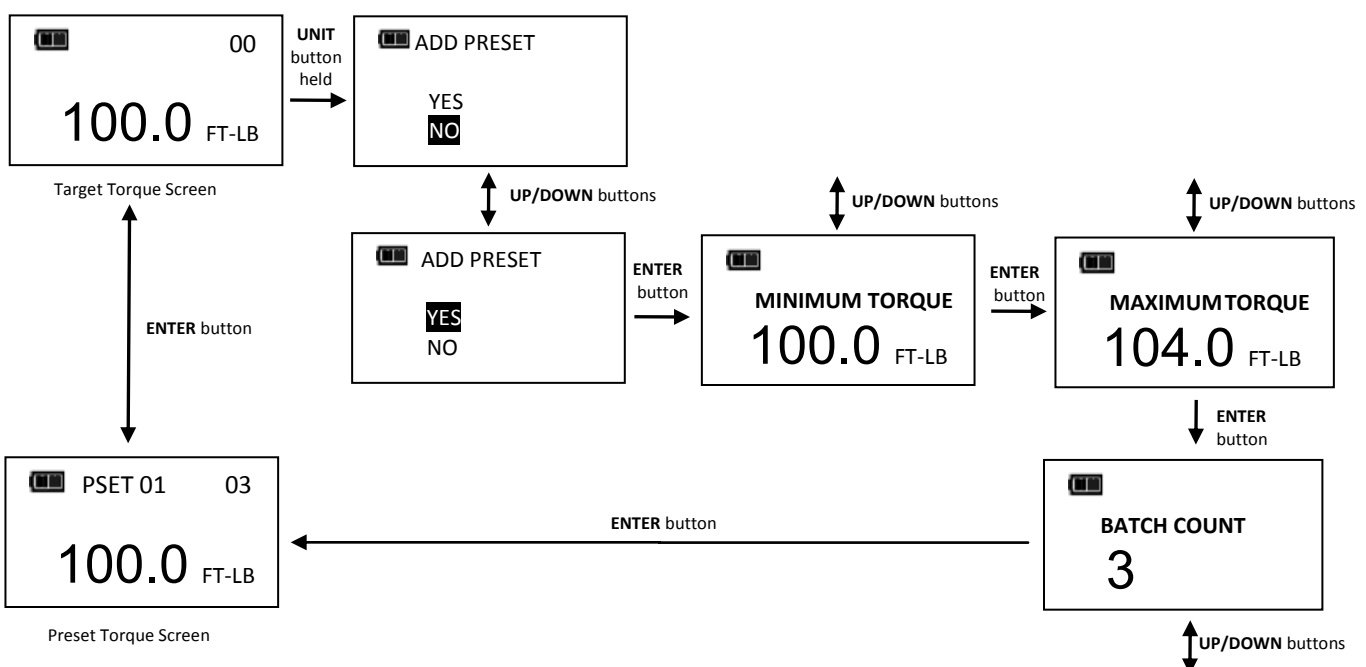











### Adding a Torque Preset

1. From target torque screen, select units of measure.
2. Press and hold **UNITS U** button for 3 seconds.
3. ADD PRESET confirmation screen is displayed. Highlight **YES** menu selection using **UP ▲**/**DOWN ▼** buttons then press **ENTER ↵** button. **NO** menu selection returns to main menu without adding a PSET.
4. **MINIMUM TORQUE** is target value at which green progress lights, audible alert and vibrator turn on. Initial **MINIMUM TORQUE** value is value from target torque screen. **MINIMUM TORQUE** can be set to any value within wrench torque range by pressing **UP ▲**/**DOWN ▼** buttons. Once desired target torque value has been set, press **ENTER ↵** button.
5. **MAXIMUM TORQUE** screen is displayed next. **MAXIMUM TORQUE** is torque value above which red progress lights turn on. Initial **MAXIMUM TORQUE** value will be **MINIMUM TORQUE** plus 4%. Maximum torque value can be set greater than **MINIMUM TORQUE** value to 10% above wrench maximum range by pressing **UP ▲**/**DOWN ▼** buttons. Once desired value has been set, press **ENTER ↵** button.
6. **BATCH COUNT** screen is displayed next. Default value is zero. Batch count range is 0 to 99. Press **UP ▲**/**DOWN ▼** buttons to increment/decrement batch count. Mode Count increments each time target torque is reached if a batch count of zero is entered. Mode Count decrements if a non-zero batch count is entered and resets to batch count value when count reaches zero. Once desired value has been set, press **ENTER ↵** button.
7. PSET target screen is displayed labeled with next available PSET number from 01 to 10.
8. To enter additional torque presets, repeatedly press **ENTER ↵** button until target torque screen is displayed and repeat steps above.



Note: To select a stored PSET or manual target torque or angle mode, repeatedly press **ENTER**  button until desired PSET or manual mode is displayed.

### Adding an Angle Preset



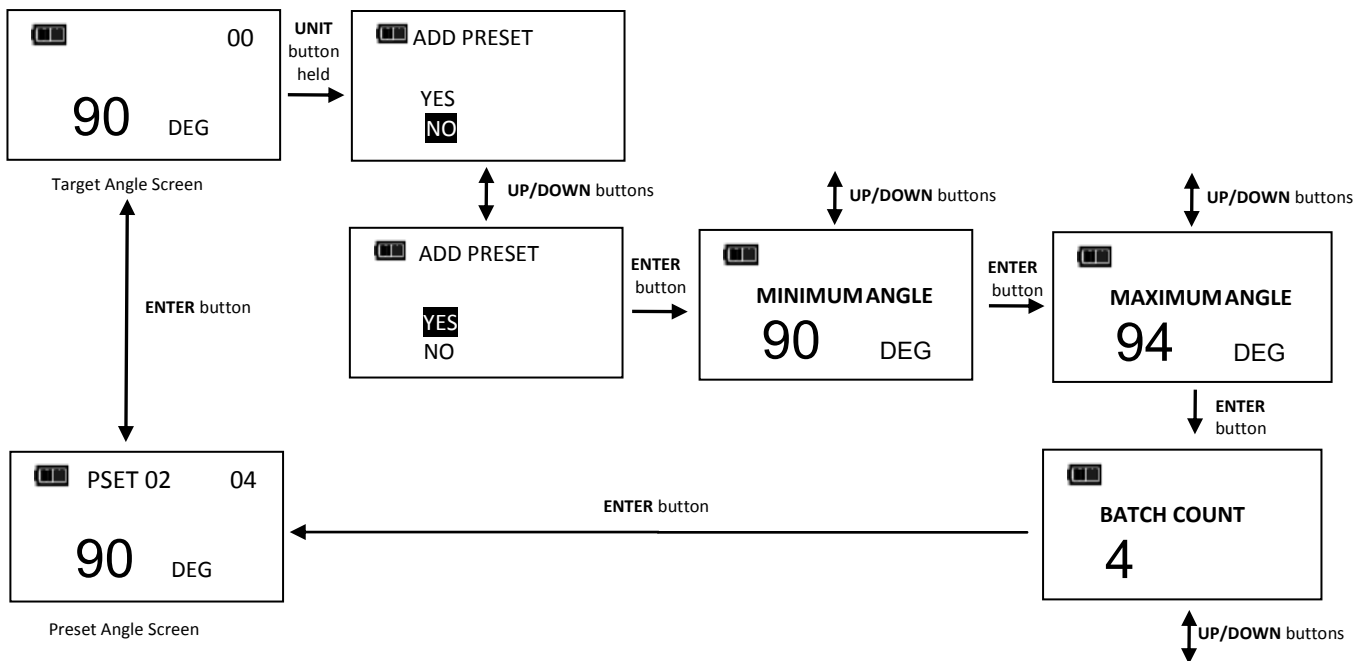



1. From target angle screen, press and hold **UNITS**  button for 3 seconds.
2. ADD PRESET confirmation screen is displayed. Highlight **YES** menu selection using **UP** /DOWN  buttons then press **ENTER**  button. **NO** menu selection returns to main menu without adding a PSET.
3. MINIMUM ANGLE screen is displayed. MINIMUM ANGLE is target value at which green progress lights, audible alert and vibrator turn on. Initial MINIMUM ANGLE value is value from target angle screen. MINIMUM ANGLE can be set from 0 to 360° by pressing **UP** /DOWN  buttons. Once desired target angle value has been set, press **ENTER**  button.
4. MAXIMUM ANGLE screen is displayed next. MAXIMUM ANGLE is angle value above which red progress lights turn on. Initial MAXIMUM ANGLE value will be MINIMUM ANGLE plus 4%. Maximum angle value can be set to any value greater than MINIMUM ANGLE by pressing **UP** /DOWN  buttons. Once desired value has been set, press **ENTER**  button.
5. BATCH COUNT screen is displayed next. Default value is zero. Batch count range is 0 to 99. Press **UP** /DOWN  buttons to increment/decrement batch count. Mode Count increments each time target angle is reached if a batch count of zero is entered. Mode Count decrements if a non-zero batch count is entered and resets to batch count value when count reaches zero. Once desired value has been set, press **ENTER**  button.
6. PSET target screen is displayed labeled with next available PSET number from 01 to 10.
7. To enter additional angle presets, repeatedly press **ENTER**  button until target angle screen is displayed and repeat steps above.



Note: To select a stored PSET or manual target torque or angle mode, repeatedly press **ENTER**  button until desired PSET or manual mode is displayed.

### Editing a Preset

Edit PSET function gives user ability to edit stored PSETS on wrench.

1. From Preset screen to be edited, press and hold **UNITS**  button for 3 seconds.
2. CHANGE PRESET screen is displayed.
3. Highlight **EDIT** selection using **UP** /DOWN  buttons then press **ENTER**  button.
4. MINIMUM TORQUE or ANGLE screen is displayed. Value can be changed by pressing **UP** /DOWN  buttons. Once desired target torque or angle value has been set, press **ENTER**  button.

5. MAXIMUM TORQUE or ANGLE screen is displayed next . Value can be changed by pressing **UP** ▲ /**DOWN** ▼ buttons. Once desired target torque or angle value has been set, press **ENTER** ◀ button.
6. BATCH COUNT screen is displayed next. Value can be changed by pressing **UP** ▲ /**DOWN** ▼ buttons. Once desired batch count value has been set, press **ENTER** ◀ button.
7. PSET target screen is displayed labeled with same PSET number.

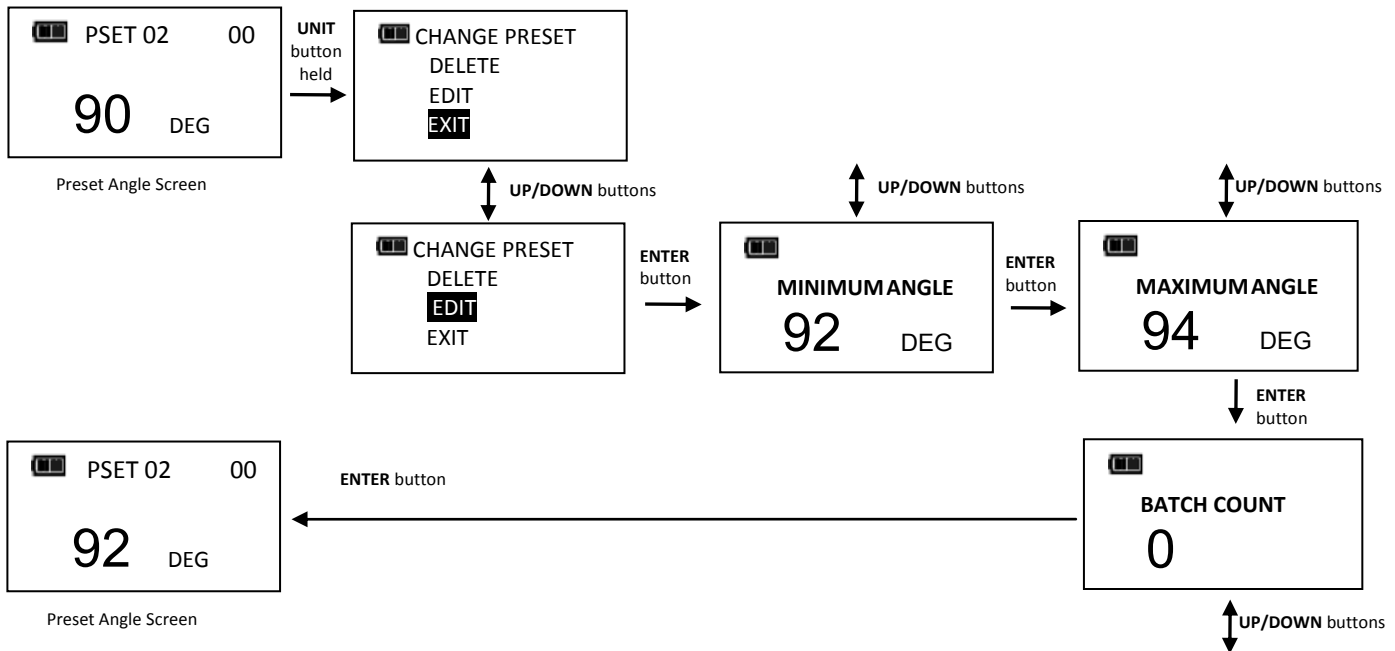

*Note: Pressing **ENTER** ◀ button while **EXIT** menu selection is highlighted will exit without editing PSET.*

### Deleting a Preset

Delete PSET function allows user to remove stored presets from wrench.

1. From Preset screen to be deleted, press and hold **UNITS** **U** button for 3 seconds.
2. CHANGE PRESET screen is displayed.
3. Highlight **DELETE** menu selection using **UP** ▲ /**DOWN** ▼ buttons and press **ENTER** ◀ button.
4. Target screen is displayed and deleted PSET is no longer available for selection.

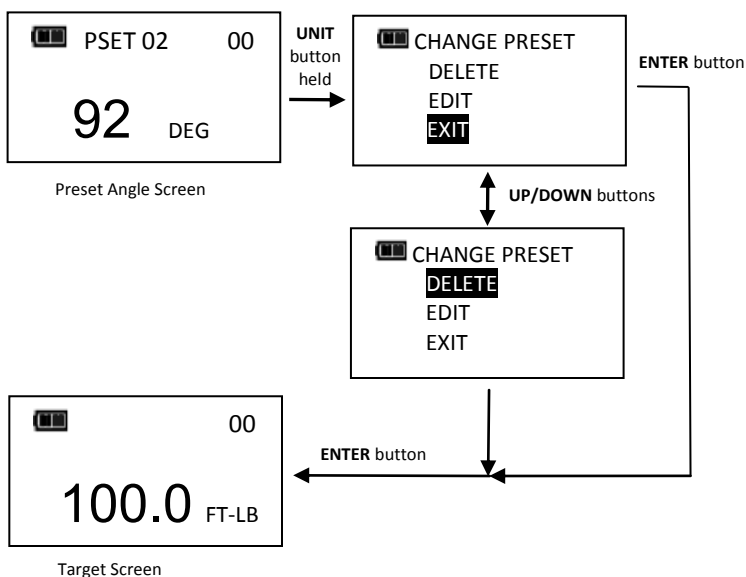





*Note: Pressing **ENTER** ◀ button while **EXIT** menu selection is highlighted will exit without deleting PSET.*

*Note: When a PSET is deleted, all other stored PSET's will retain their original PSET numbers. When a new PSET is entered, it will be assigned first available PSET number in sequence.*



## • Advanced Settings

### Accessing Advanced Settings

Advanced settings are accessed from **SETTINGS** menu selection on main menu.

1. From target torque or angle screen, press and hold **ENTER**  button for 3 seconds.
2. Highlight **SETTINGS** menu selection using **UP** /**DOWN**  buttons.
3. Press **ENTER**  button to display Settings menu.

Menu Selections:

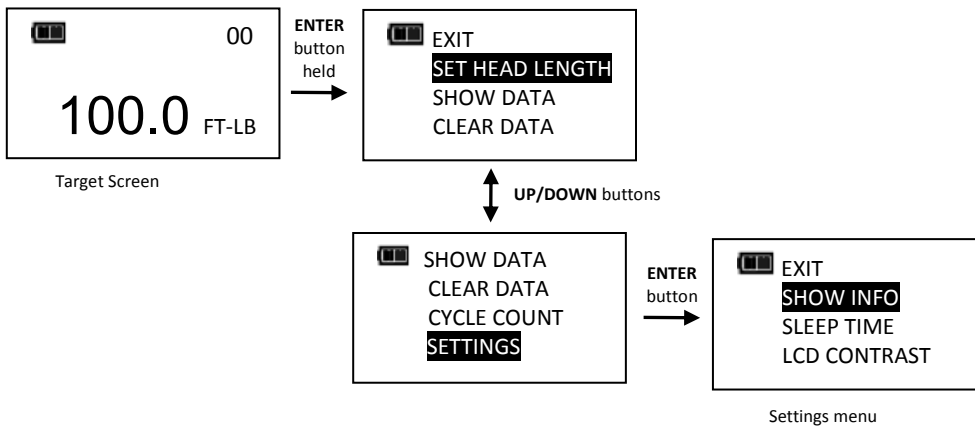

- EXIT - Exits Settings menu and returns to target screen.
  - SHOW INFO - Displays wrench operational information.
  - SLEEP TIME - Displays power down interval setup screen.
  - LCD CONTRAST - Displays LCD contrast setup screen.
  - KEY BEEP - Displays button press beep enable/disable setup screen.
  - AUTO BACKLIGHT - Displays auto backlight enable/disable screen to turn on backlight during measurement.
  - TOGGLE BACKLIGHT - Displays **BACKLIGHT**  button toggle or timeout enable/disable screen.
  - VIBRATOR CONFIG - Displays vibrator ON/OFF configuration for when target reached.
4. To exit Settings menu and return to target torque or angle screen, press **ENTER**  button while **EXIT** menu selection is highlighted.



*Note: All user configurable settings are stored in non-volatile memory and are retained while power is off.*

### Show Info

Show Info menu selection displays wrench operational information.

1. From Settings menu, press **ENTER**  button while **SHOW INFO** selection is highlighted.
2. SHOW INFO screen is displayed.
3. **UP** /**DOWN**  buttons are used to scroll screen.

Operational Information:

- CAL: Date of last wrench calibration.
  - ISD: In-Service Date.
  - TCF: Torque Calibration Factor.
  - ACF: Angle Calibration Factor.
  - VER: Software version.
  - OVR CNT: Overtorque Counter tracks how many times an over-torque event occurred on wrench (torque >125% of full scale).
  - TQZ: Torque Zero Offset.
  - ANZ: Angle Zero Offset.
4. Pressing **ENTER**  button exits Show Info screen and returns to Settings menu.

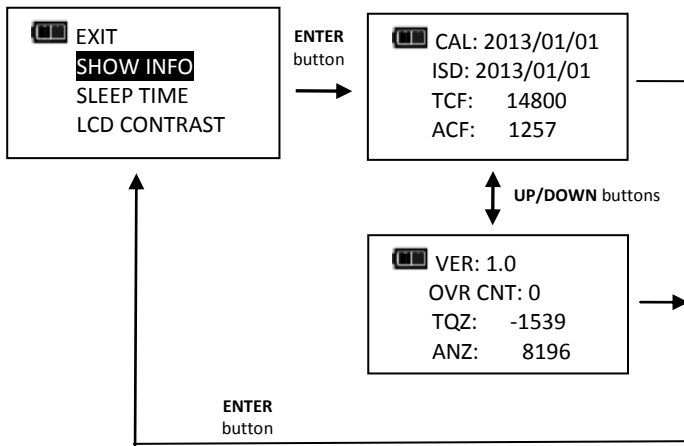

## Setting Sleep Time

This function will allow user to set interval wrench enters power-down state following last applied torque or button press.

1. From Settings menu, use **UP ▲**/**DOWN ▼** buttons to highlight **SLEEP TIME** selection then press **ENTER ↵** button.
2. SLEEP TIME screen is displayed.
3. Use **UP ▲**/**DOWN ▼** buttons to select sleep interval.

Selectable Intervals:

- 2 MIN (factory default)
- 5 MIN
- 10 MIN
- 30 MIN
- 1 HR
- 2 HR
- 8 HR

4. Press **ENTER ↵** button to accept selection and exit to Settings menu.

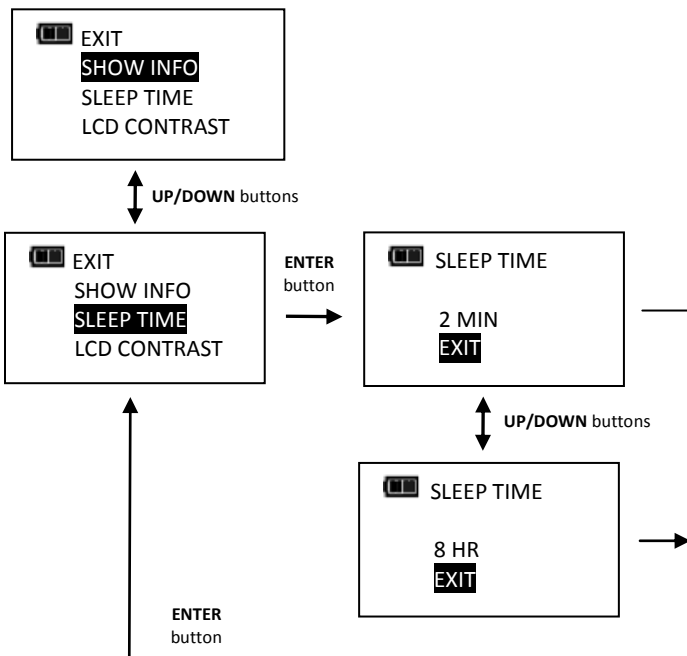

## Setting LCD Contrast

This function will allow user to set LCD contrast for optimal viewing.

1. From Settings menu, use **UP ▲**/**DOWN ▼** buttons to highlight **LCD CONTRAST** selection then press **ENTER ↵** button.
2. CONTRAST screen is displayed.

- Use **UP ▲**/**DOWN ▼** buttons while viewing display to change contrast to desired level.  
Selectable levels: 20 to 80 in increments of 5 (factory default = 40).
- Press **ENTER ↵** button to accept selection and exit to Settings menu.

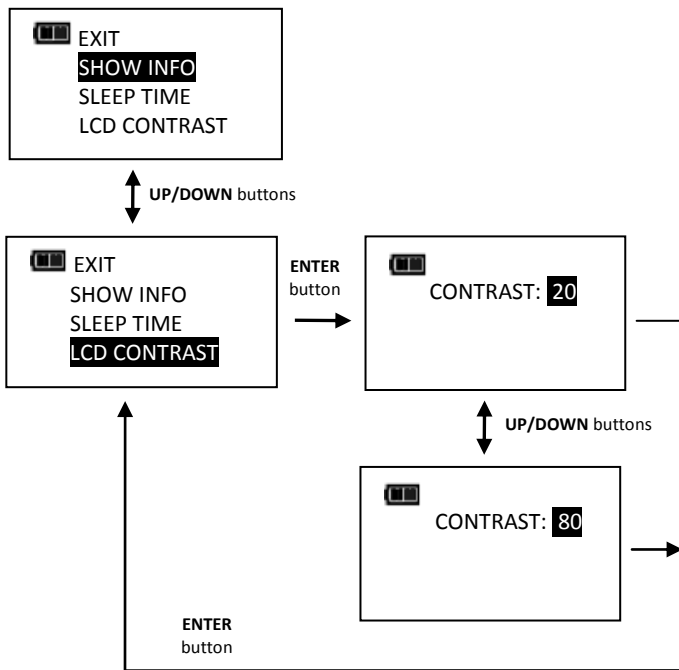

### Key Beep Setup

This function will allow user to enable or disable audio feedback when a button is pressed.

- From Settings menu, use **UP ▲**/**DOWN ▼** buttons to highlight **KEY BEEP** selection then press **ENTER ↵** button.
- KEY BEEP screen is displayed.
- Use **UP ▲**/**DOWN ▼** buttons to highlight ENABLE (factory default) or DISABLE selection.
- Press **ENTER ↵** button to accept selection and exit to Settings menu.

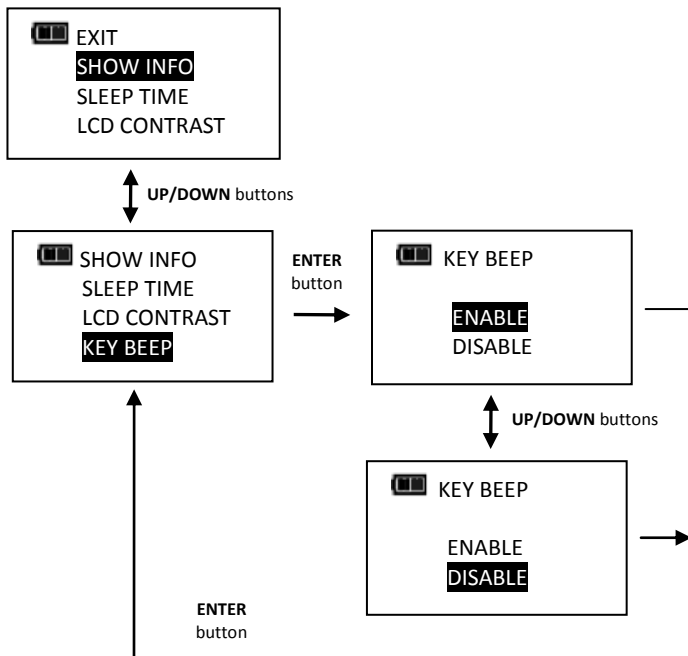

### Auto Backlight Setup

This function will allow user to enable or disable backlight from turning on during torque or angle measurement.

- From Settings menu, use **UP ▲**/**DOWN ▼** buttons to highlight **AUTO BACKLIGHT** selection then press **ENTER ↵** button.
- AUTO BACKLIGHT screen is displayed.
- Use **UP ▲**/**DOWN ▼** buttons to highlight ENABLE (factory default) or DISABLE selection.
- Press **ENTER ↵** button to accept selection and exit to Settings menu.

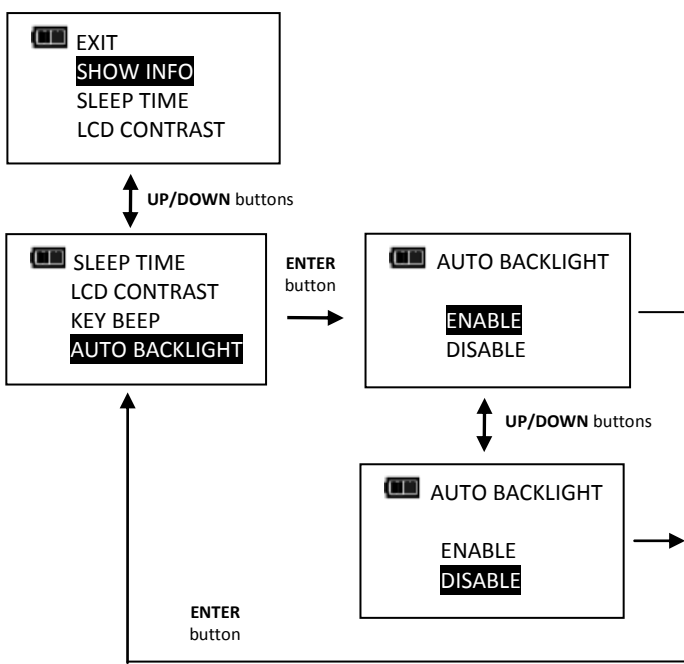

### Toggle Backlight Setup

This function will allow user to enable or disable backlight toggle function. If toggle mode is disabled, **BACKLIGHT** button turns on backlight and it automatically turns off after five seconds following any last button press. If toggle mode is enabled, a **BACKLIGHT** button press will turn on backlight and it will remain on until next **BACKLIGHT** button press.

1. From Settings menu, use **UP** / **DOWN** buttons to highlight **TOGGLE BACKLIGHT** selection then press **ENTER** button.
2. TOGGLE BACKLIGHT screen is displayed.
3. Use **UP** / **DOWN** buttons to highlight ENABLE or DISABLE (factory default) selection.
4. Press **ENTER** button to accept selection and exit to Settings menu.

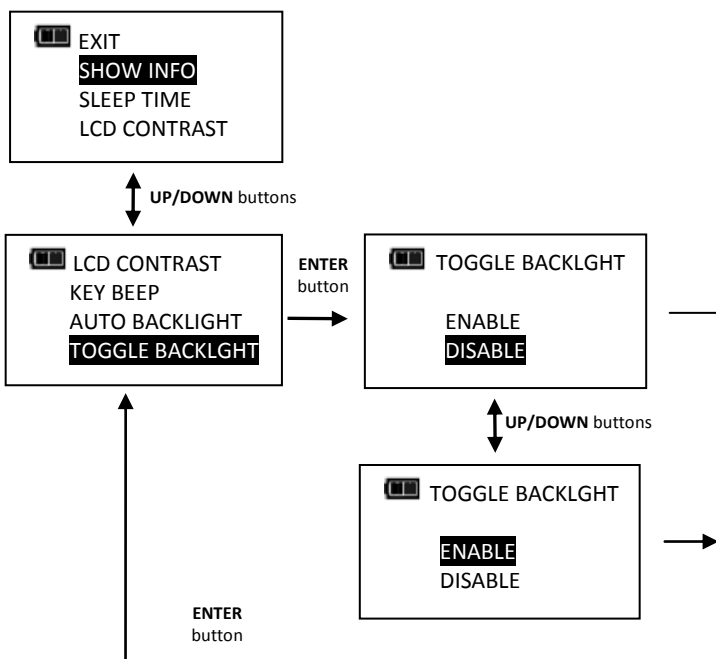

*Note: Backlight will turn off when wrench powers down either by **POWER** button press or sleep time.*

*Note: If toggle backlight is enabled and backlight is on, backlight will remain on during and after applying torque.*

## Vibrator Configuration

This function will allow user to configure vibrator for On or Off when target is reached for preference and/or battery power savings.

1. From Settings menu, use **UP ▲**/**DOWN ▼** buttons to highlight **VIBRATOR CONFIG** selection then press **ENTER ↵** button.
2. VIBRATOR CONFIG screen is displayed.
3. Use **UP ▲**/**DOWN ▼** buttons to toggle ON or OFF selection.
4. Press **ENTER ↵** button to accept selection and exit to Settings menu.

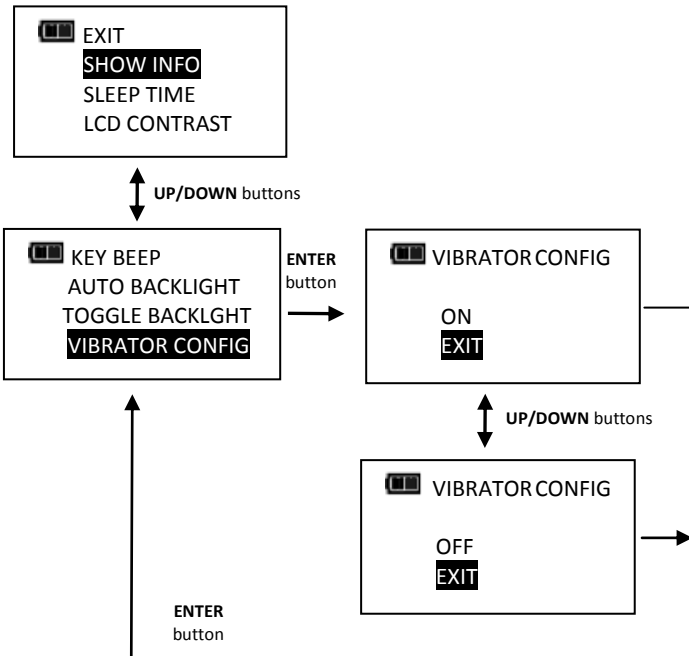

## • Advanced Configuration

### Accessing Advanced Configuration

Advanced configuration is accessed from **CONFIGURE** menu selection on main menu.

1. From target torque or angle screen, press and hold **ENTER ↵** button for 3 seconds.
2. Highlight **CONFIGURE** menu selection using **UP ▲**/**DOWN ▼** buttons.
3. Press **ENTER ↵** button to display Configure menu.

Menu Selections:

- EXIT - Exits Configure menu and returns to target torque or angle screen.
  - MODE SETUP - Displays wrench mode setup menu.
  - CALIBRATION - Displays wrench calibration menu (password protected).
  - SET DATE/TIME - Displays clock date and time entry screens.
  - SET CAL INTRVAL - Displays calibration interval setup screen (requires clock date and time setup).
4. To exit Configure menu and return to target torque or angle screen, press **ENTER ↵** button while **EXIT** menu selection is highlighted.

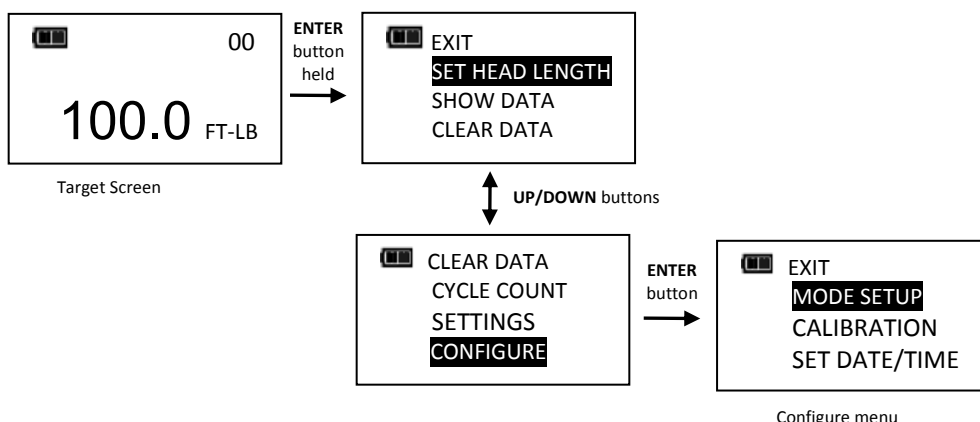



*Note: All user configurable settings are stored in non-volatile memory and are retained while power is off.*



## Mode Setup

Mode setup menu allows user to enable/disable Torque THEN angle mode.

1. From Configure menu, press **ENTER**  button while **MODE SETUP** selection is highlighted.
2. Mode Setup menu is displayed.

Menu Selections:





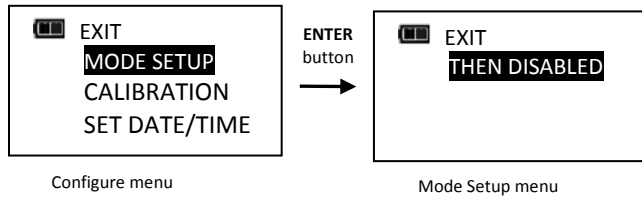

- EXIT - Exits Mode setup menu and returns to Configure menu screen.
- THEN DISABLED - Displays THEN Mode enable/disable screen.

3. Use **UP** /**DOWN**  buttons to highlight menu selections.
4. Press **ENTER**  button while **EXIT** menu selection is highlighted to return to Configure menu.



## Enable/Disable Torque THEN Angle Mode

This function will allow user to enable or disable Torque THEN Mode.



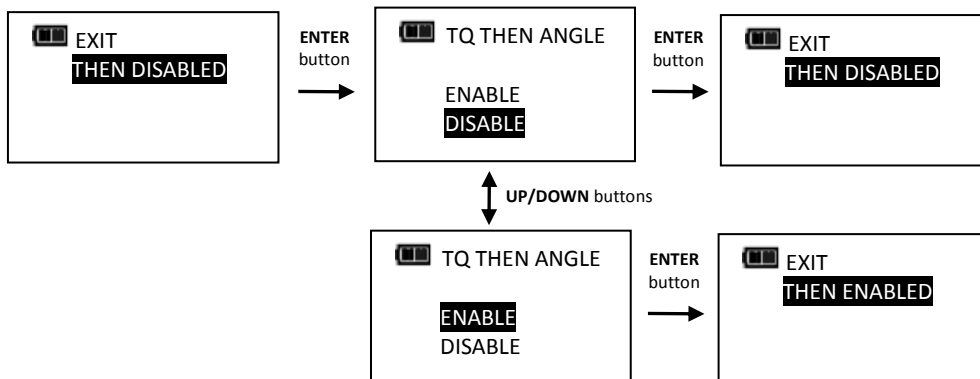



1. From Mode Setup menu, use **UP** /**DOWN**  buttons to highlight **THEN DISABLED** selection (factory default) then press **ENTER**  button.
2. TQ THEN ANGLE enable/disable screen is displayed.
3. Use **UP** /**DOWN**  buttons to select ENABLE or DISABLE selection.
4. Press **ENTER**  button to accept selection and exit to Mode Setup menu.



*Note: Menu selection indicates current configuration (ENABLED or DISABLED).*

## Torque THEN Angle Mode

Torque THEN Angle mode is setup by first setting a target torque and units then a target angle before selecting Torque THEN Angle mode. In Torque THEN Angle mode, when applied torque reaches target torque, wrench automatically switches to angle mode for angle measurement. Progress lights indicate applied torque progress while torque is measured and angle when angle is measured.

1. From target torque screen, use **UP** /**DOWN**  buttons to set target torque and **UNITS**  button to select torque measurement units then press **ENTER**  button.
2. Angle target screen is displayed. Use **UP** /**DOWN**  buttons to set target angle then press **ENTER**  button.
3. Torque THEN Angle mode screen is displayed.
4. Apply torque until target is reached then rotate wrench to target angle.

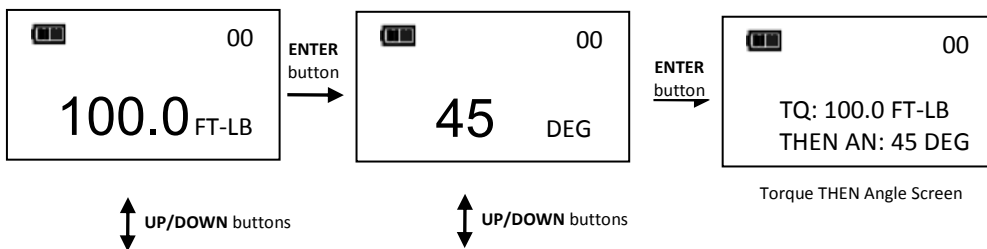

*Note: **UNITS U** button can be used to select torque units while on Torque THEN Angle screen.*

*Note: Torque THEN Angle Presets are entered by pressing and holding Units button while on Torque THEN Angle screen. Refer to "Adding a Torque Preset" and "Adding an Angle Preset" in Basic section for parameter entry.*

*Note: Torque cycle is not recorded in memory unless both torque and angle reach targets.*

*Note: Red and yellow progress lights turn on if torque exceeds 110% of wrench full scale or if angle exceeds target plus 4% in manual mode.*

*Note: Red and yellow progress lights turn on if torque exceeds maximum torque or if angle exceeds maximum angle in Preset mode.*

## **Calibration**

Calibration menu is password protected. Contact your local Snap-on Repair Center regarding Calibration menu.

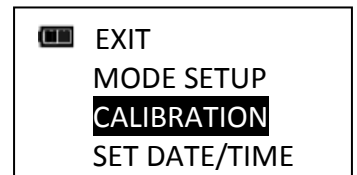

## **Setting Date and Time**

Set Date/Time function allows user to set real-time-clock date and time for time stamping data records, recording last calibration date and notifying user of an expired calibration interval.

*Note: When date and time is set for first time, In-Service date is also set and is used for calculating initial calibration interval (see "Setting Calibration Interval" in Advanced Configuration section).*

1. From Configure menu, use **UP ▲/DOWN ▼** buttons to highlight **SET DATE/TIME** selection then press **ENTER ↵** button.
2. SET DATE screen is displayed with year highlighted.
3. Use **UP ▲/DOWN ▼** buttons to set year then press **ENTER ↵** button to highlight month.
4. Use **UP ▲/DOWN ▼** buttons to set month then press **ENTER ↵** button to highlight day.
5. Use **UP ▲/DOWN ▼** buttons to set day then press **ENTER ↵** button.
6. SET TIME screen is displayed with Hour highlighted.
7. Use **UP ▲/DOWN ▼** buttons to set hour then press **ENTER ↵** button to highlight minutes.
8. Use **UP ▲/DOWN ▼** buttons to set minutes then press **ENTER ↵** button to highlight seconds.
9. Use **UP ▲/DOWN ▼** buttons to set seconds then press **ENTER ↵** button.
10. Clock is set and Configure menu is displayed.

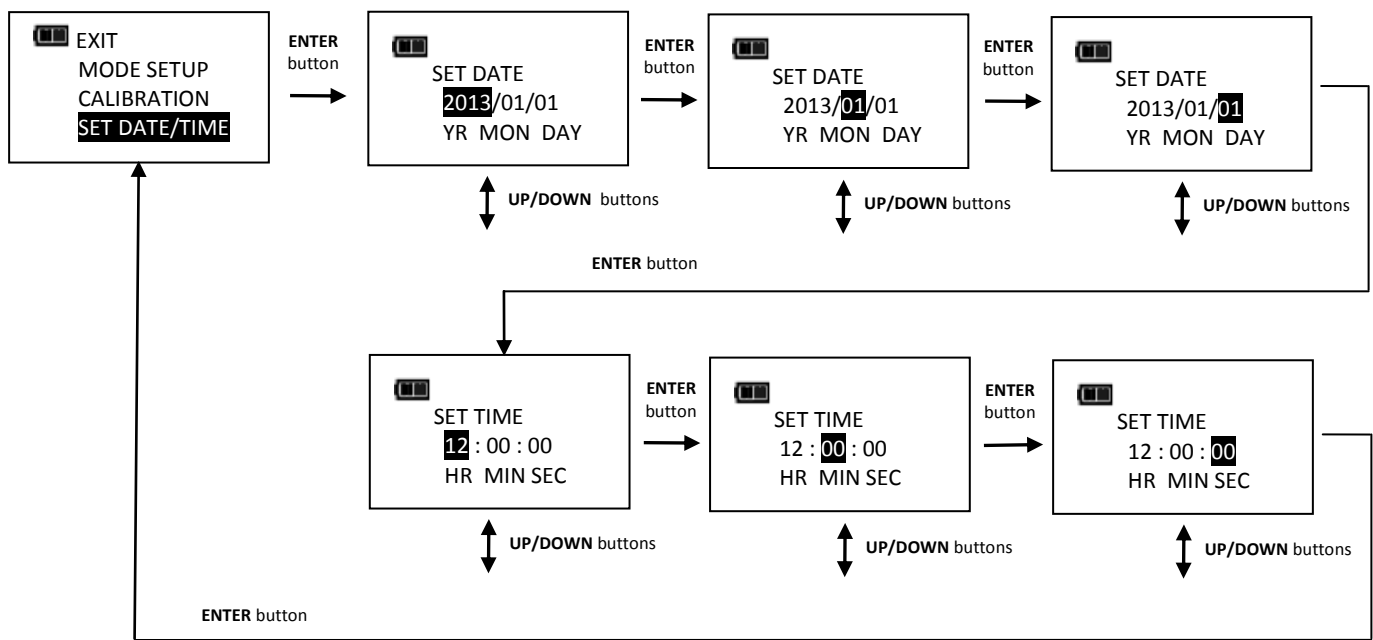

Note: Year selection will scroll up from 2013. Month selection will scroll from 1 to 12. Day selection will scroll from 1 to 31.

Note: Hour selection will scroll through 0 to 23. Minute and Second selections will scroll through 0 to 59.

Note: If batteries are removed from wrench for longer than 20 minutes, clock will revert to default settings and must be re-entered at power on.

### Setting Calibration Interval

This function will allow user to set calibration interval for when "CAL NEEDED" message will be displayed.

1. From Configure menu, use **UP ▲**/**DOWN ▼** buttons to highlight **SET CAL INTRVAL** selection then press **ENTER ↵** button.
2. CAL INTERVAL screen is displayed.
3. Use **UP ▲**/**DOWN ▼** buttons to change calibration interval.

Selectable Intervals:

- DISABLED (factory default)
- 3 MON
- 6 MON
- 12 MON

4. Press **ENTER ↵** button to accept selection and exit to Configure menu.

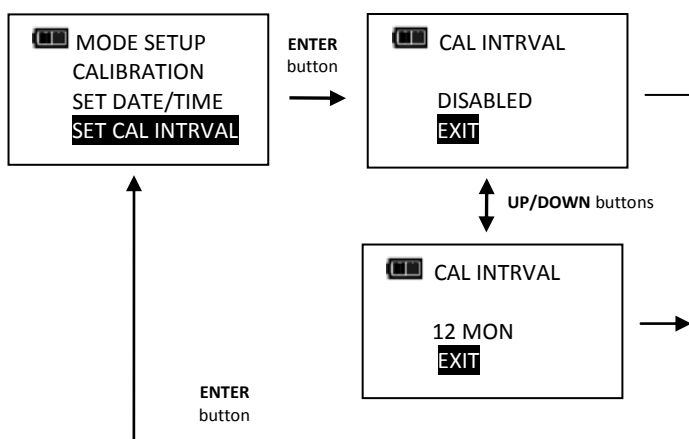











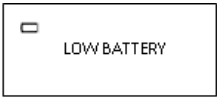

Note: Clock Date and Time must be set before calibration interval will function. If batteries are removed from wrench for longer than 20 minutes, clock will revert to default settings and must be re-entered at power on.

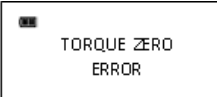
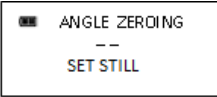
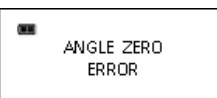

Note: Calibration interval is calculated from either In-Service Date or last Calibration date (see SHOW INFO menu) depending on which is more recent date. When clock Date is greater than In-Service or Last Calibration date, plus Cal Interval, "CAL NEEDED" message will be displayed on power up and after a re-zero. Pressing **ENTER**  button will continue to target menu. Applying torque while "CAL NEEDED" message is displayed will immediately display torque or angle measurement and return to target menu when released.

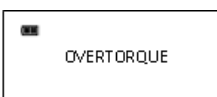
Note: As an alternative to calibration interval, a Calibration Cycle Counter is provided in Calibration menu (Contact your local Snap-on Repair Center regarding Calibration menu).

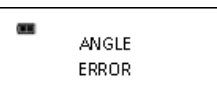
## • Troubleshooting

Note: If any of following issues persist, return wrench to an authorized Snap-on repair center.

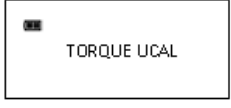
Issue	Possible Cause	Resolution
Wrench does not turn on when <b>POWER</b>  button pressed	Dead/No batteries	Replace batteries
	Software glitch	Cycle power using end-cap
Torque reading out of spec	Calibration required	Recalibrate
	Incorrect head length entered	Enter correct offset head length
Wrench did not retain settings while batteries were removed	Batteries removed before settings were saved in non-volatile memory.	Clear data, re-enter settings and press and hold <b>POWER</b>  button to power down wrench before removing batteries
Torque or angle displayed while no torque applied	Torque or angle zeroed while torque applied	Place wrench on stable surface with no torque applied and press <b>POWER</b>  button to re-zero wrench
 LOW BATTERY	Low battery	Press <b>ENTER</b>  button to continue using wrench and replace batteries soon
 REPLACE BATTERY	Dead battery	Press <b>POWER</b>  button to turn off wrench and replace batteries
 TORQUE ZERO ERROR	Torque applied while zeroing	Remove torque and re-zero
	Wrench over torqued	Recalibrate
	Wrench improperly calibrated	Recalibrate
	Torque sensor failure	Return to Snap-on Repair Center
 ANGLE ZEROING -- SET STILL	Wrench moving during zeroing	Place wrench on stable surface
	Gyro unstable	Return to Snap-on Repair Center
 ANGLE ZERO ERROR	<b>POWER</b>  button pressed during angle zeroing (Aborted zeroing to access menus)	Place wrench on stable surface and press <b>POWER</b>  button to re-zero
 OVERTORQUE	Over 125% of full scale torque applied	Cycle power using <b>POWER</b>  button and recalibrate
 ANGLE ERROR	Wrench rotated too fast during angle measurement	Place wrench on stable surface and press <b>POWER</b>  button to re-zero

Issue	Possible Cause	Resolution
	Memory failure	Clear data memory
	Torque uncalibrated	Calibrate torque
	Angle uncalibrated	Calibrate angle

## ● USE OF ADAPTORS, EXTENSIONS AND UNIVERSALS

Anytime an adaptor, extension or universal is used with a torque wrench in such a way that fastener distance is different than torque wrench square drive distance at calibration, an adjustment to head length is required to get a proper fastener torque reading.

When using wobble extension or a universal, do not exceed more than 15 degrees of offset from perpendicular drive. Do not use a long extension with flex-drive at full flex.

## ● CALIBRATION

Contact your Snap-on sales representative for calibration services.

## ● CERTIFICATION

This TechAngle<sup>®</sup> wrench was calibrated at factory using angular displacement and torque measurement instruments that are traceable to National Institute of Standards and Technology (N.I.S.T.). Torque parameters comply with ISO 6789-2003 and ASME B107-28-2010. Note: no U.S. or International Standards exist for angle wrenches.

**IMPORTANT!** Calibration events are recorded in wrench memory which provides evidence to void factory certification.

## ● MAINTENANCE / SERVICE

Clean wrench by wiping with a damp cloth. DO NOT use solvents, thinners or carburetor cleaners.

DO NOT immerse in anything.

Service, repair and calibration are to be done by Snap-on Service Centers only. Contact your Snap-on Tools representative.

Ratchet head repair can be done by Snap-on Representative or user.

## ● Battery Replacement

### Replace with three "AA" cells only.

- Do not attempt to recharge alkaline cells.
- Do not mix different battery types.
- Replace all batteries at same time.
- Store wrench in dry place.
- Remove batteries when storing wrench unused longer than 3 months.

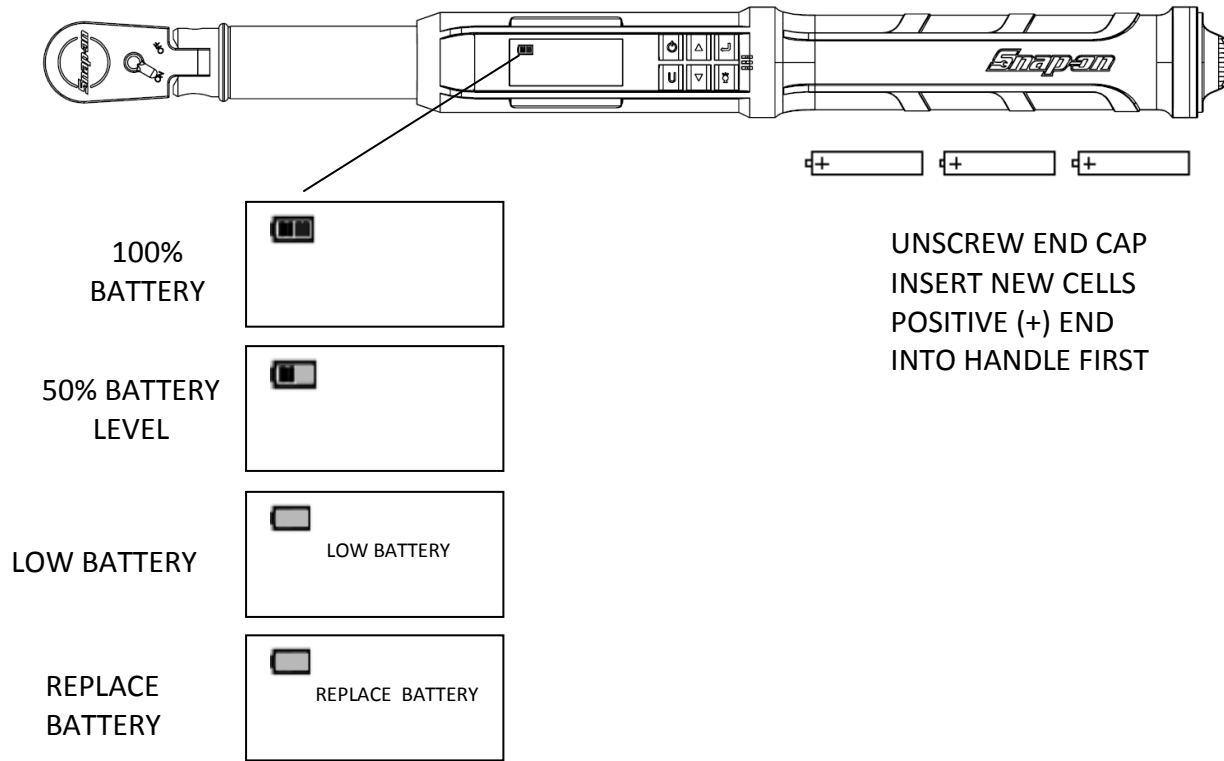

*Note: When replacing batteries, real-time-clock will maintain date and time for 20 minutes.*

*Note: Turn End Cap counter-clockwise to unscrew.*



*Note: When Replace Battery screen is displayed wrench will no longer operate until batteries are replaced. Only **POWER**  button functions which immediately turns off wrench.*

## ● Memory Indicators

DATA IN MEMORY		Less than 50 torque and angle records
MEMORY FULL		50 torque or angle records stored in memory. Oldest record will be replaced by next record.
MEMORY ERROR		Memory read or write error. Return to Snap-on Repair Center if persists after clearing memory.

# INSTRUÇÕES DE SEGURANÇA IMPORTANTES



## **ATENÇÃO** *Risco de projeção de partículas.*

O torque excessivo pode causar ruptura. Forçar os batentes flexíveis da cabeça flexível pode fazer com que esta se quebre. Uma chave de ângulo descalibrada pode quebrar peças ou ferramentas. Ferramentas manuais, soquetes ou acessórios quebrados podem causar ferimentos. A aplicação de força excessiva pode fazer com que chaves pé de galo ou chaves de porca aberta escorreguem.

- Leia **este manual completamente** antes de usar o TORQUÍMETRO ELETRÔNICO.
- Para garantir a precisão, não se deve movimentar o torquímetro no modo de ângulo.
- Para a segurança pessoal e para evitar danos ao torquímetro, siga as boas práticas profissionais para o uso de ferramentas e a instalação de peças de fixação.
- A recalibragem periódica é necessária para manter a precisão.
- Use óculos de proteção, seja como usuário ou espectador.**
- Certifique-se de que todos os componentes, inclusive todos os adaptadores, extensões, chaves de fenda e soquetes, sejam regulados para aguentar o torque aplicado.
- Cumpra todos os avisos, cuidados e procedimentos de equipamentos, sistemas e fabricantes quando utilizar este torquímetro.
- Use um soquete de tamanho correto para a peça de fixação.
- Não utilize soquetes desgastados ou rachados.
- Substitua as peças de fixação com bordas arredondadas.
- Para evitar danos ao torquímetro:** Nunca utilize o torquímetro desligado. Sempre **LIGUE** o torquímetro para que o torque aplicado seja medido.
  - Não aperte o botão **LIGA/DESLIGA**  ao aplicar torque ou enquanto o torquímetro estiver em movimento.
  - Nunca utilize o torquímetro para soltar peças de fixação.
  - Não utilize extensões, como um cano, no punho do torquímetro.
  - Verifique se o torquímetro é capaz de resistir a cada aplicação antes de prosseguir.
  - Verifique a calibragem se a ferramenta cair.
- Certifique-se de que a alavanca de sentido da catraca esteja totalmente engatada na posição certa.
- Verifique a calibragem do torquímetro caso saiba ou suspeite que sua capacidade foi excedida.
- Não force o encaixe da cabeça flexível contra batentes.
- Sempre puxe (não empurre) o punho do torquímetro e ajuste sua postura para impedir uma possível queda caso algo ceda.
- Não tente recarregar as pilhas alcalinas.
- Guarde o torquímetro em local seco.
- Remova as pilhas quando for guardar o torquímetro por mais que 3 meses.



## **AVISO** *Risco de choque elétrico.*

O choque elétrico pode causar ferimentos. O punho plástico não é isolante. Não utilize em circuitos elétricos energizados.

## **GUARDE ESTAS INSTRUÇÕES**

### **Aviso de isenção de responsabilidade**

A operação do torquímetro TechAngle® não é permitida em nenhum Estado-membro da União Europeia se as instruções operacionais não estiverem no idioma do Estado em questão. Entre em contato com a Snap-on se uma tradução for necessária.

# Especificações

## Tipo de cabeça

- Encaixe quadrado, flexível e vedado com 72 ou 80 dentes

## Visor

- TIPO DE VISOR: LCD de matriz de pontos (Resolução 192 x 65)
- SENTIDO DE VISUALIZAÇÃO: 6:00
- ILUMINAÇÃO: BRANCA (LED)

## Teclado hermético



**POWER:** LIGA/DESLIGA e zera novamente o torque e o ângulo



**ENTER:** seleção do modo de medição e confirmação no menu



**SUBIR:** aumenta as definições de torque e ângulo e navega no menu



**DESCER:** diminui as definições de torque e ângulo e navega no menu



**UNIDADES:** seleciona uma unidade (pés-lbs, polegadas-lbs, Nm, Kgm, Kg-cm, dNm) e abre o menu de valores predefinidos (PSET)



**ILUMINAÇÃO LCD:** ilumina todas as telas e indica o último torque ou ângulo de pico

## Funções

- Set (definir) : torque ou ângulo desejados
- Track (acompanhar) : exibição em tempo real do torque ou rotação angular acumulada com luzes de progresso
- Peak Hold (manter pico) : iluminação intermitente por 10 segundos do torque de pico ou do torque/ângulo de pico quando da liberação do torque
- Peak Recall (recordar pico): exibe o último torque de pico ou torque/ângulo de pico ao apertar o botão
- Memory (memória): exibe as últimas 50 leituras de torque de pico ou torque/ângulo de pico

## Precisão

- Temperatura: a 22° C (72° F)
- Ângulo:  $\pm 1\%$  de leitura  $\pm 1^\circ$  a velocidade angular  $> 10^\circ/s < 180^\circ/s \pm 1^\circ$  do dispositivo de teste
- Torque: 

	Sentido horário	Anti-horário
• Torque: {	$\pm 2\%$	$\pm 3\%$ de leitura, 20% a 100% da escala total
	$\pm 4\%$	$\pm 6\%$ de leitura, 10% a 19% da escala total
	$\pm 8\%$	$\pm 10\%$ de leitura, 5% a 9% da escala total

## Dimensões: Comprimento / Peso

Modelo	Comprimento	Peso
ATECH1FR240B	16,4 pol.	1,9 lb.
ATECH2FR100B	17,9 pol.	2,3 lb.
ATECH3FR250B	26,6 pol.	3,7 lb.

## Limite predefinido

- ÂNGULO: 0 a 360° no sentido horário ou anti-horário (resolução do visor 1°)
- TORQUE: (limite e resolução do visor conforme indicado abaixo)

Modelo	Encaixe quad.	pés-lb	pol-lb	Nm	Kgm	kg-cm	dNm	sobrecarga (pés-lb)
ATECH1FR240B	¼ pol.	1,00-20,00	12,0-240,0	1,36-27,12	N/A	13,8-276,5	13,6-271,2	25
ATECH2FR100B	⅜ pol.	5,0-100,0	60-1200	6,8-135,6	N/A	69-1383	68-1356	125
ATECH3FR250B	½ pol.	12,5-250,0	150-3000	16,9-339,0	1,73-34,56	N/A	N/A	312

**Temperatura de operação:**

0°F a 130°F (-18°C a 54°C)

**Temperatura de armazenamento:**

0°F a 130°F (-18°C a 54°C)

**Desvio de medição:**

ÂNGULO: -0,12 graus angulares por grau C

TORQUE: +0,01% de leitura por grau C

**Umidade:**

Até 90% sem condensação

**Pilhas:**

Três pilhas alcalinas "AA", até 40 horas de operação contínua

**Desligamento automático padrão:**

depois de 2 minutos de tempo ocioso (ajustável, consulte Definições avançadas)



# Instruções do usuário

## • Funções básicas (guia rápido)



Figura 1

Insira três pilhas "AA" novas no punho do torqueímetro.

### Sequência de acionamento do torqueímetro

*Obs.: Não ligue o torqueímetro ao aplicar torque, do contrário, a compensação de torque zero ficará incorreta e a ferramenta indicará uma leitura de torque quando o torque for liberado. Se isso acontecer, zere novamente o torqueímetro apertando momentaneamente o botão **LIGA/DESLIGA** com o torqueímetro sobre uma superfície estável sem nenhum torque aplicado a ele.*

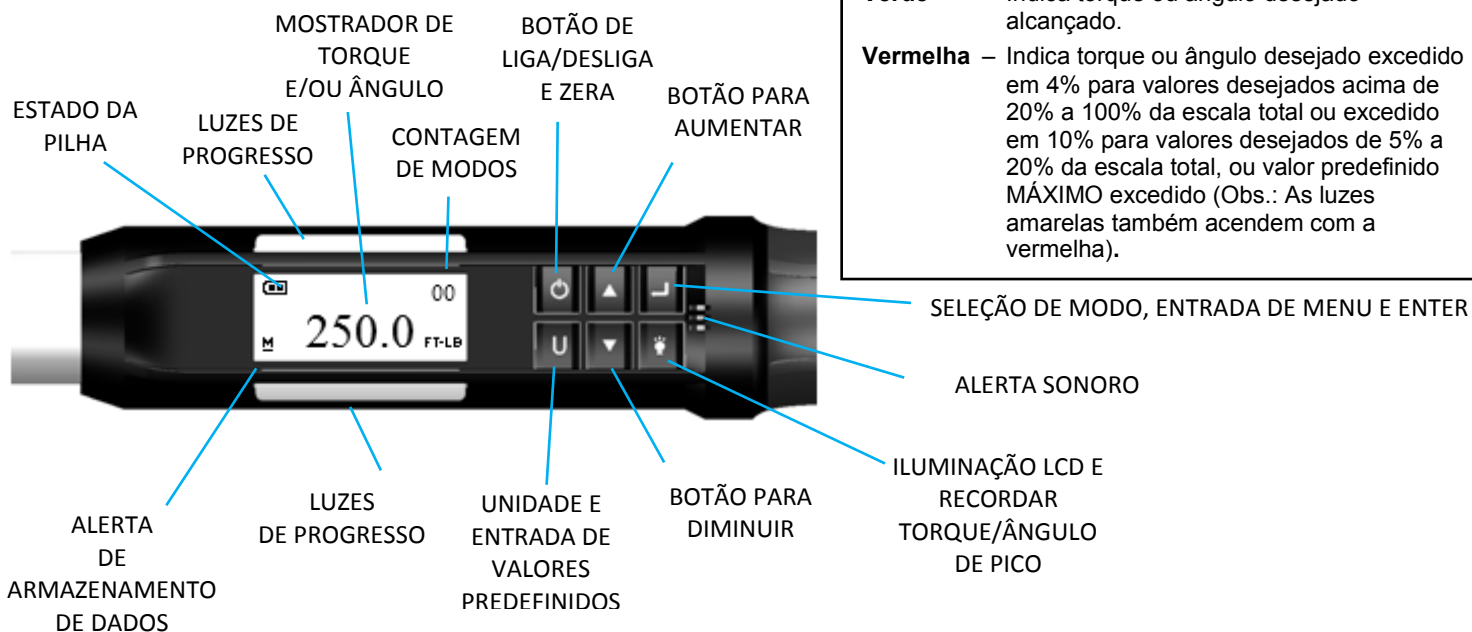
1. Ligue o torqueímetro.

Aperte momentaneamente o botão **LIGA/DESLIGA**. O logotipo da Snap-on será exibido, seguido por uma tela de redefinição do torque para zero. Se a medição anterior foi uma medição de ângulo, a tela de redefinição do ângulo para zero segue a tela de redefinição do torque para zero. Depois de redefinir para zero, a tela de torque desejado ou ângulo desejado é exibida, dependendo do modo da medição anterior.

2. Selecione o modo de medição.

Altere entre as telas de TORQUE e ÂNGULO desejado apertando repetidamente o botão **ENTER**.

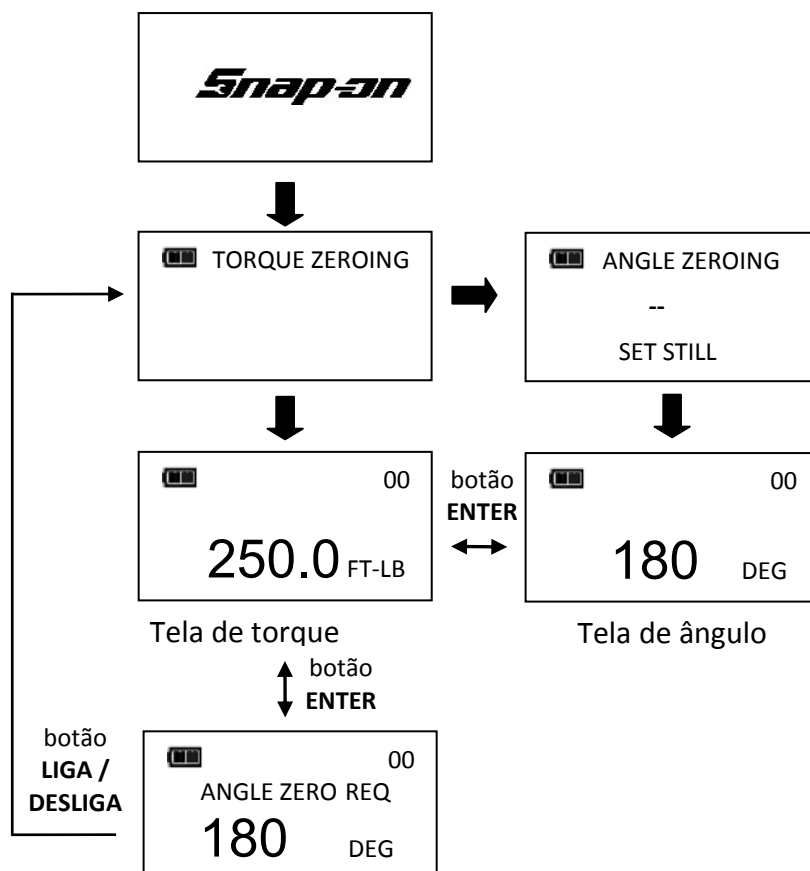



*Obs.: Se o torquímetro for ligado no modo de medição somente do torque, o ângulo não será zerado até que se faça a alteração para o modo de medição do ângulo, quando a redefinição para zero do torque e do ângulo começará automaticamente depois de 2 segundos. O torquímetro deve ser colocado sobre uma superfície estável sem aplicar nenhum torque.*

*Obs.: Apertar o botão **ENTER**  enquanto o ângulo está sendo zerado cancelará a função de redefinição para zero a fim de permitir que o usuário selecione outro modo de medição.*

### **Modo de torque**

1. Defina o torque desejado.

Use os botões **SUBIR** /**DESCER**  para mudar o valor do TORQUE desejado.





2. Selecione a unidade de medida.

Aperte repetidamente o botão **UNIDADE**  enquanto na tela de TORQUE desejado até que a unidade desejada seja exibida.

3. Aplique TORQUE.

Segure no centro do punho (cuidado para NÃO retirar a tampa das pilhas) e aplique torque lentamente à peça de fixação até que as luzes de progresso fiquem verdes e um alarme sonoro de meio segundo e a vibração do punho sinalizem que o usuário deve parar.

4. Libere o TORQUE.

Observe a leitura de TORQUE de pico piscando no visor LCD por 10 segundos. Apertar os botões **ILUMINAÇÃO**  enquanto o torque de pico pisca fará com que o valor continue sendo exibido até soltar o botão. Aperte momentaneamente o botão **SUBIR** /**DESCER** , **ENTER**  ou **UNIDADE**  para voltar imediatamente à tela de TORQUE desejado. A reaplicação de TORQUE iniciará imediatamente outro ciclo de medição de TORQUE.

5. Recorde a leitura de TORQUE de pico.

Para recordar a última medida de TORQUE de pico, aperte e segure o botão **ILUMINAÇÃO**  button for approximately 3 seconds. Peak TORQUE will flash for 10 seconds.



### **Modo de ângulo**

*Obs.: Não aplique torque enquanto o torque e o ângulo são redefinidos para zero, do contrário, a compensação de torque zero ficará incorreta e o torquímetro indicará uma leitura de ângulo quando o torque for liberado. Se isso acontecer, zere novamente o torquímetro apertando momentaneamente o botão **LIGA/DESLIGA**  com a ferramenta sobre uma superfície estável sem nenhum torque aplicado a ela.*

1. Redefina o ângulo para zero

Se a mensagem "ANGLE ZERO REQ" (necessária redefinição do ângulo para zero) for exibida, aguarde 2 segundos para a redefinição automática do ângulo para zero antes de aplicar torque ou mover o torquímetro.





2. Defina o ângulo desejado.

Use os botões **SUBIR** /**DESCER**  para mudar o valor do ÂNGULO desejado.

3. Aplique torque e gire o torquímetro.

Segure no centro do punho (cuidado para NÃO retirar a tampa das pilhas) e aplique torque lentamente à peça de fixação e gire o torquímetro até que as luzes de progresso fiquem verdes e um alarme sonoro de meio segundo e a vibração do punho sinalizem que o usuário deve parar.

4. Libere o torque.

Observe as leituras alternantes de TORQUE e ÂNGULO de pico piscando no visor LCD por 10 segundos. Pressionar o botão **ILUMINAÇÃO**  enquanto o ângulo de pico pisca fará com que o valor continue sendo exibido até soltar o botão. Aperte momentaneamente o botão **SUBIR** /**DESCER** , **ENTER**  ou **UNIDADE**  para voltar imediatamente à tela de ÂNGULO desejado. A reaplicação de torque (pela catraca) antes de exibir a tela de valor desejado continuará o acúmulo de ÂNGULO ao girar o torquímetro.

## 5. Recorde a leitura do ÂNGULO de pico

Para recordar a última medida de ÂNGULO de pico, aperte e segure o botão **ILUMINAÇÃO**  por cerca de 3 segundos. O TORQUE e o ÂNGULO de pico serão exibidos alternadamente por 10 segundos.

### Contagem dos ciclos de modo

O recurso de contagem de ciclos de modo da TechAngle® serve para indicar o número de vezes que o torquímetro chegou ao torque desejado no modo de medição de torque ou ao ângulo desejado no modo de medição de ângulo.

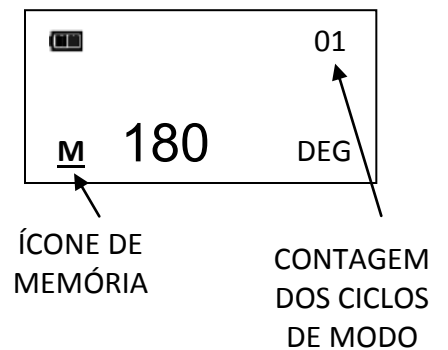





### Contagem dos ciclos dos modos de torque e de ângulo

1. Um contador numérico localizado na direita superior da tela de torque ou ângulo desejado aumentará depois de cada ciclo de torque ou ângulo se o torque ou ângulo aplicado chegar ao valor desejado.
2. Ao alternar entre o modo de torque e o modo de ângulo usando o botão **ENTER**  ou alterar o valor desejado, o contador numérico volta para zero (00). O contador NÃO reiniciará ao redefinir o torque ou ângulo para zero, ao entrar/sair do menu ou ao desligar a ferramenta.
3. O ícone de memória acenderá indicando que ao menos um dado de ciclo de torque ou ângulo foi armazenado na memória.

### Menu principal

O menu principal exibe informações operacionais do torquímetro.

1. Na tela de torque ou ângulo desejado, aperte e segure o botão **ENTER**  por 3 segundos.
2. Utilize os botões **SUBIR** /**DESCER**  para destacar e selecionar uma opção de menu e, então, aperte o botão **ENTER** .





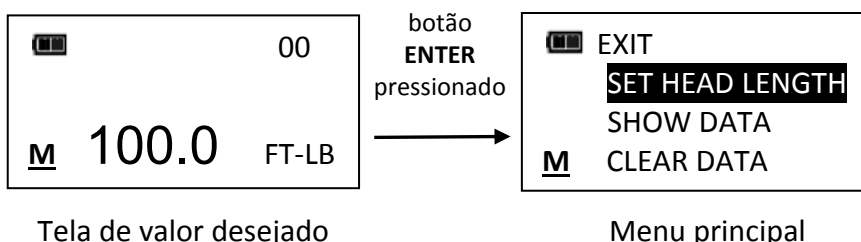



Opções de menu:

- EXIT: fecha o menu principal e volta à tela de valor desejado.
  - SET HEAD LENGTH: exibe a tela de entrada do comprimento de cabeça do torquímetro.
  - SHOW DATA: exibe os dados de torque e ângulo armazenados.
  - CLEAR DATA: exclui os dados de torque e ângulo armazenados.
  - CYCLE COUNT: exibe a tela de contagem dos ciclos de torque/ângulo.
  - SETTINGS: exibe o menu de definições avançadas (consulte a seção Definições avançadas).
  - CONFIGURE: exibe o menu de configuração avançada (consulte a seção Configuração avançada).
3. Para sair do menu Settings e voltar à tela de torque ou ângulo desejado, aperte o botão **ENTER**  com a opção de menu **EXIT** selecionada.



## Definição do comprimento de cabeça

*Obs.: Se um adaptador ou extensão for adicionado ao torquímetro, o comprimento do adaptador/extensão em uso deve ser informado para corrigir o comprimento de cabeça usado para calibrar o torquímetro sem a necessidade de recalibragem.*

1. Para inserir um comprimento de cabeça, na tela de torque ou ângulo desejado, aperte e segure o botão **ENTER**  por 3 segundos.
2. Com a opção de menu **SET HEAD LENGTH** selecionada, aperte momentaneamente o botão **ENTER** .
3. A tela Set Head Length (definir comprimento de cabeça) é exibida a seguir. O comprimento de cabeça padrão é o comprimento de cabeça na calibragem. Utilize os botões **SUBIR** /**DESCER**  para aumentar/diminuir o comprimento de cabeça. Apertar e segurar os botões
4. **SUBIR** /**DESCER**  aumentará/diminuirá o valor progressivamente com mais rapidez. Apertar os botões **SUBIR** /**DESCER**  ao mesmo tempo redefinirá o comprimento de cabeça para zero.
5. As unidades de comprimento padrão estão em polegadas. Aperte o botão **UNIDADE** **U** para mudar para milímetros.
6. Aperte o botão **ENTER**  depois de definir o comprimento para voltar ao menu principal. Se o comprimento padrão for alterado, a mensagem "OFFSET IN USE" (compensação em uso) será exibida na tela de valor desejado.

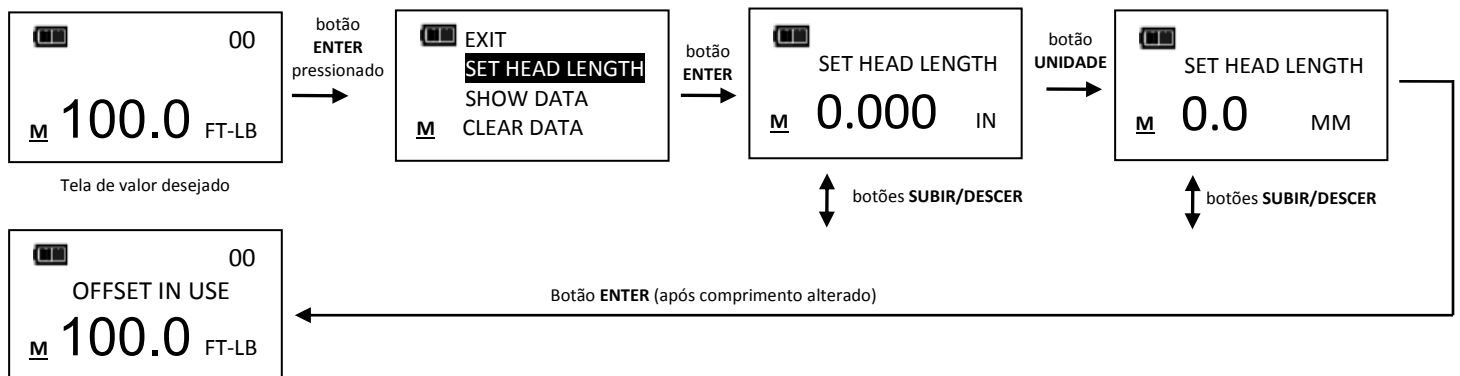

*Obs.: O comprimento de cabeça inserido é o comprimento medido desde o centro do encaixe até o centro da peça de fixação.*

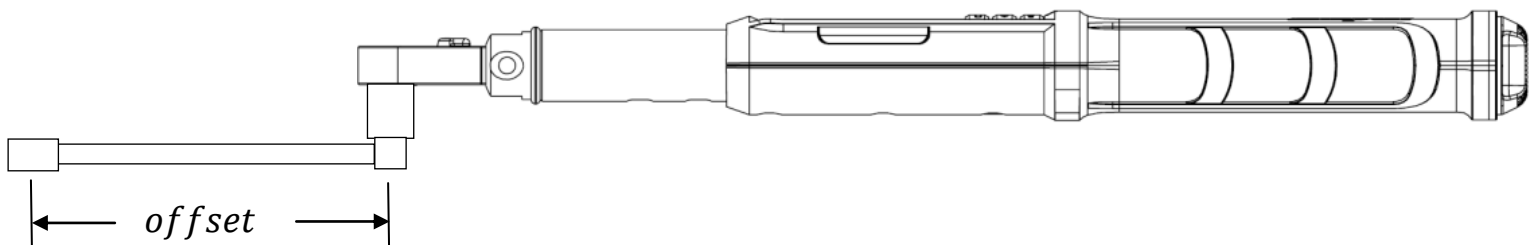

## Uso de compensações negativas

*Obs.: Insira um valor negativo para compensação quando utilizar a ferramenta no sentido contrário.*

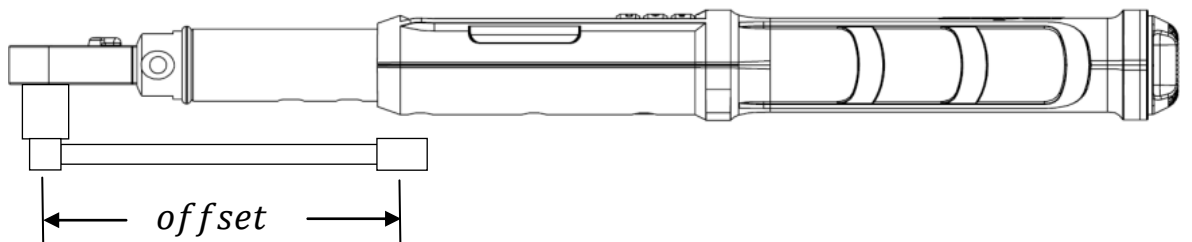

Quando o comprimento de uma compensação for negativo, os valores máximos de fixação desejados são limitados pelas fórmulas a seguir:

Chave de 240 polegadas-lb:

Torque desejado máximo =  
compensação \* 24 + 240

Chave de 100 pés-lb:

Torque desejado máximo =  
compensação \* 8 + 100

Chave de 250 pés-lb:

Torque desejado máximo =  
compensação \* 12 + 250

Compensação	Valor desejado máx.
-1"	216 polegadas-lb
-2"	192 polegadas-lb
-3"	168 polegadas-lb
-4"	144 polegadas-lb







Compensação	Valor desejado máx.
-1"	92 pés-lb
-2"	84 pés-lb
-3"	76 pés-lb
-4"	68 pés-lb

Compensação	Valor desejado máx.
-1"	238 pés-lb
-2"	226 pés-lb
-3"	214 pés-lb
-4"	202 pés-lb

*Obs.: Quando utilizar uma compensação negativa, a introdução de um torque desejado maior que os valores máximos acima pode causar um erro de torque excessivo antes que se chegue ao torque de fixação desejado e, possivelmente, danificar o torquímetro.*

### Visualização de dados de torque e ângulo armazenados

Dados de torque são armazenados na memória depois de cada ciclo de torque se o torque aplicado chegar ao valor desejado. Dados de torque e ângulo são armazenados na memória depois de cada ciclo de ângulo se o ângulo aplicado chegar ao valor desejado. O indicador de memória é exibido quando os dados são armazenados na memória não volátil.

1. Para visualizar os dados de torque e ângulo armazenados, na tela de torque ou ângulo desejado, aperte e segure o botão **ENTER**  por 3 segundos.
2. Selecione a opção de menu **SHOW DATA** apertando os botões **SUBIR**  / **DESCER**  e, então, aperte o botão **ENTER** .
3. Na tela Show Data, passe por cada registro de dados armazenados apertando os botões **SUBIR**  / **DESCER** .



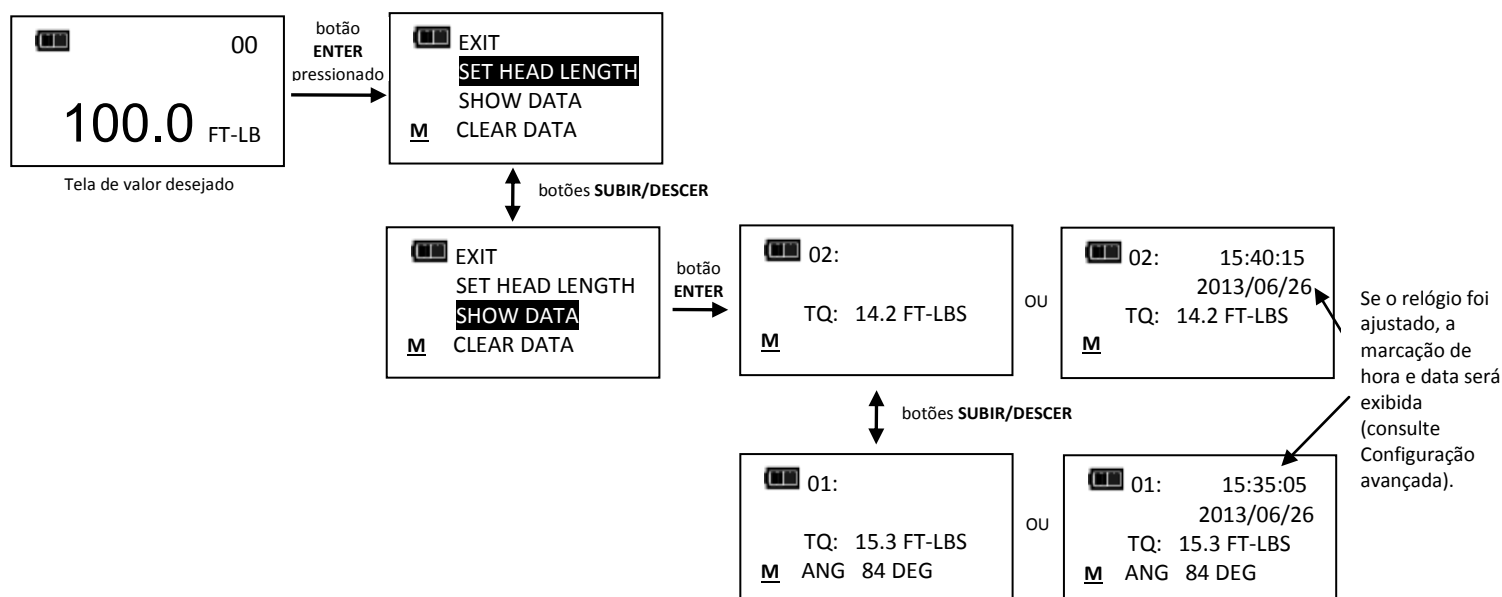

Exemplo: 02 = contador de dados da tela Show Data: TQ = valor de torque de pico  
01 = contador de dados da tela Show Data: TQ = valor de torque de pico: ANG = valor de ângulo de pico

4. Aperte o botão **ENTER**  enquanto estiver na tela Show Data para voltar ao menu principal.



*Obs.: Um máximo de 50 registros de dados pode ser armazenado na memória. Quando a memória estiver cheia, um ícone de memória cheia será exibido. Dados novos substituirão os registros mais antigos até que a memória seja esvaziada.*





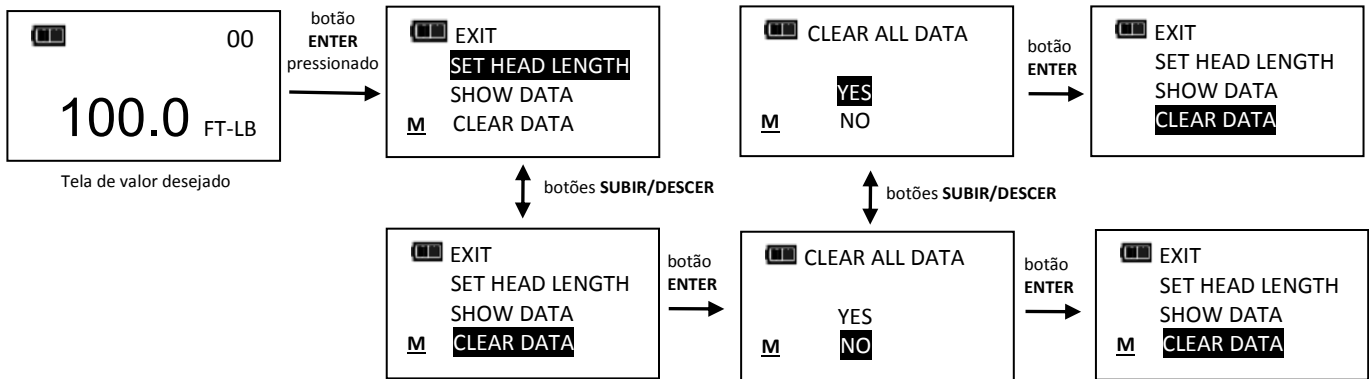

## Exclusão de dados de torque e de ângulo armazenados

1. Na tela de torque ou ângulo desejado, aperte e segure o botão **ENTER**  por 3 segundos.
2. Selecione a opção de menu **CLEAR DATA** usando os botões **SUBIR** /**DESCER**  e, então, aperte o botão **ENTER**  para exibir a tela CLEAR ALL DATA (excluir todos os dados).
3. Na tela CLEAR ALL DATA, selecione a opção de menu **YES**, para excluir todos os dados armazenados, ou a opção de menu **NO**, para sair sem excluir os dados.
4. Aperte o botão **ENTER**  depois de selecionar uma opção.



## Visualização e limpeza do contador de ciclos do torquímetro

Toda vez que o torque ou ângulo desejado é atingido, o contador de ciclos do torquímetro aumenta. A contagem de ciclos máxima é de 999.999.

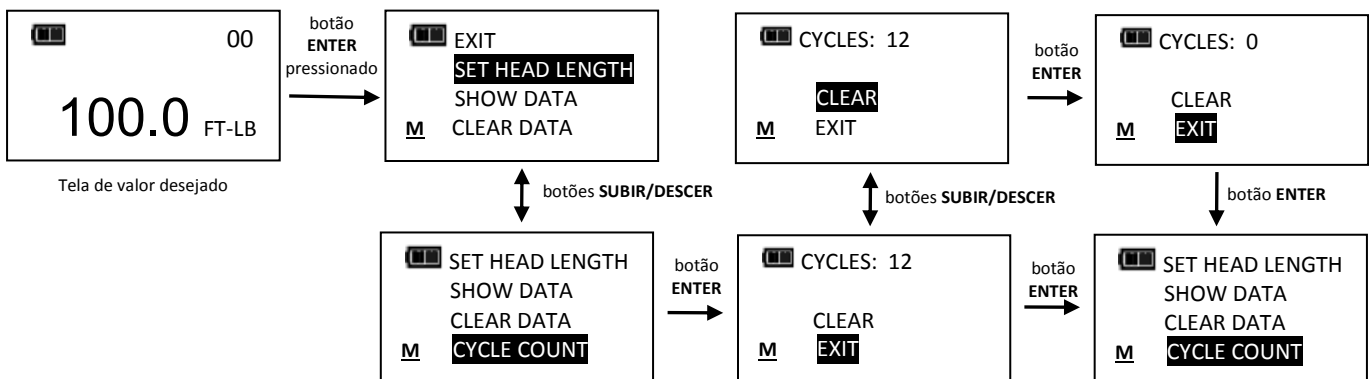

1. Na tela de torque ou ângulo desejado, aperte e segure o botão **ENTER**  por 3 segundos.
2. Selecione a opção de menu **CYCLE COUNT** usando os botões **SUBIR** /**DESCER** .
3. Aperte o botão **ENTER**  para exibir a tela CYCLES (ciclos).
4. Para sair da tela CYCLE COUNT sem excluir a contagem, aperte o botão **ENTER**  com a opção de menu **EXIT** selecionada.
5. Para zerar a contagem de ciclos do torquímetro, selecione a opção de menu **CLEAR** e aperte o botão **ENTER** .
6. A opção de menu **EXIT** é selecionada automaticamente depois de limpar o contador. Aperte o botão **ENTER**  para voltar ao menu principal.



## Valores desejados predefinidos (PSET)

A função PSET (valor predefinido) dá ao usuário a possibilidade de configurar 10 valores de torque ou ângulo predefinidos, cada um com um valor mínimo (desejado), um valor máximo (limite) e um valor de contagem de lotes. Os valores predefinidos são armazenados na memória não volátil para que não se percam quando o aparelho for desligado.

### Adicionar um valor de torque predefinido

1. Na tela de torque desejado, selecione as unidades de medida.
2. Aperte e segure o botão **UNIDADE** **U** por 3 segundos.
3. A tela de confirmação ADD PRESET (adicionar valor predefinido) é exibida. Selecione a opção de menu **YES** usando os botões **SUBIR** /**DESCER**  e, então, aperte o botão **ENTER** . A opção de menu **NO** volta para o menu principal sem adicionar um valor PSET.

4. **MINIMUM TORQUE** (torque mínimo) é o valor desejado no qual as luzes de progresso verdes acendem, o alarme sonoro toca e o vibrador aciona. O valor **MINIMUM TORQUE** inicial é o valor na tela de torque desejado. O valor **MINIMUM TORQUE** pode ser definido como qualquer valor dentro da capacidade de torque do torquímetro apertando os botões **SUBIR ▲** / **DESCER ▼**. Depois de definir o valor de torque desejado, aperte o botão **ENTER ↵**.
5. A tela **MAXIMUM TORQUE** (torque máximo) é exibida a seguir. **MAXIMUM TORQUE** é o valor de torque acima do qual as luzes de progresso vermelhas acendem. O valor **MAXIMUM TORQUE** inicial será o **MINIMUM TORQUE** mais 4%. O valor de torque máximo pode ser maior que o valor **TORQUE MINIMUM** até 10% acima da capacidade de torque do torquímetro apertando os botões **SUBIR ▲** / **DESCER ▼**. Depois de definir o valor desejado, aperte o botão **ENTER ↵**.
6. A tela **BATCH COUNT** (contagem de lotes) é exibida a seguir. O valor padrão é zero. O limite de contagem de lotes é de 0 a 99. Aperte os botões **SUBIR ▲** / **DESCER ▼** para aumentar/diminuir a contagem de lotes. A contagem de modos aumenta toda vez que se chega ao torque desejado se a contagem de lotes for definida como zero. A contagem de modos diminui se uma contagem de lotes diferente de zero for definida e o valor da contagem de lotes reinicia quando a contagem chega a zero. Depois de definir o valor desejado, aperte o botão **ENTER ↵**.
7. A tela de valor **PSET** desejado é exibida com o próximo número de **PSET** disponível de 01 a 10.
8. Para inserir outros valores de torque predefinidos, aperte repetidamente o botão **ENTER ↵** até que a tela de torque desejado seja exibida e repita as etapas acima.

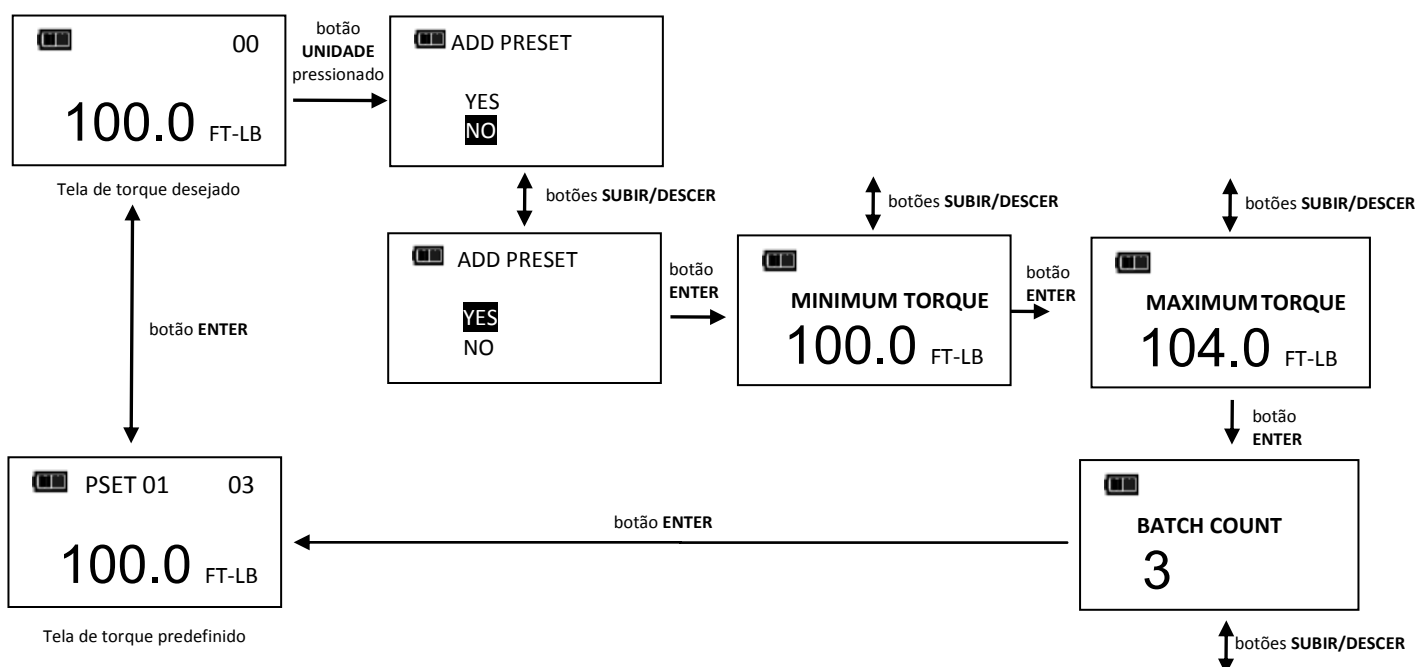

*Obs.: Para selecionar um valor PSET armazenado ou modo de torque ou ângulo desejado manual, aperte repetidamente o botão **ENTER ↵** até que o valor PSET desejado ou o modo manual seja exibido.*

### **Adicionar um valor de ângulo predefinido**

1. Na tela de ângulo desejado, aperte e segure o botão **UNIDADE U** por 3 segundos.
2. A tela de confirmação **ADD PRESET** (adicionar valor predefinido) é exibida. Selecione a opção de menu **YES** usando os botões **SUBIR ▲** / **DESCER ▼** e, então, aperte o botão **ENTER ↵**. A opção de menu **NO** volta para o menu principal sem adicionar um valor PSET.
3. A tela **MINIMUM ANGLE** (ângulo mínimo) é exibida. **MINIMUM ANGLE** é o valor desejado no qual as luzes de progresso verdes acendem, o alarme sonoro toca e o vibrador aciona. O valor **MINIMUM ANGLE** inicial é o valor na tela de ângulo desejado. O **MINIMUM ANGLE** pode ser definido entre 0° e 360° apertando os botões **SUBIR ▲** / **DESCER ▼**. Depois de definir o valor de ângulo desejado, aperte o botão **ENTER ↵**.
4. A tela **MAXIMUM ANGLE** (ângulo máximo) é exibida a seguir. **MAXIMUM ANGLE** é o valor de ângulo acima do qual as luzes de progresso vermelhas acendem. O valor **MAXIMUM ANGLE** inicial será o **MINIMUM ANGLE** mais 4%. O valor de ângulo máximo pode ser definido como qualquer valor maior que o **MINIMUM ANGLE** apertando os botões **SUBIR ▲** / **DESCER ▼**. Depois de definir o valor desejado, aperte o botão **ENTER ↵**.

- A tela BATCH COUNT (contagem de lotes) é exibida a seguir. O valor padrão é zero. O limite de contagem de lotes é de 0 a 99. Aperte os botões **SUBIR ▲** / **DESCER ▼** para aumentar/diminuir a contagem de lotes. A contagem de modos aumenta toda vez que se chega ao ângulo desejado se a contagem de lotes for definida como zero. A contagem de modos diminui se uma contagem de lotes diferente de zero for definida e o valor da contagem de lotes reinicia quando a contagem chega a zero. Depois de definir o valor desejado, aperte o botão **ENTER ↵**.
- A tela de valor PSET desejado é exibida com o próximo número de PSET disponível de 01 a 10.
- Para inserir outros valores de ângulo predefinidos, aperte repetidamente o botão **ENTER ↵** até que a tela de ângulo desejado seja exibida e repita as etapas acima.

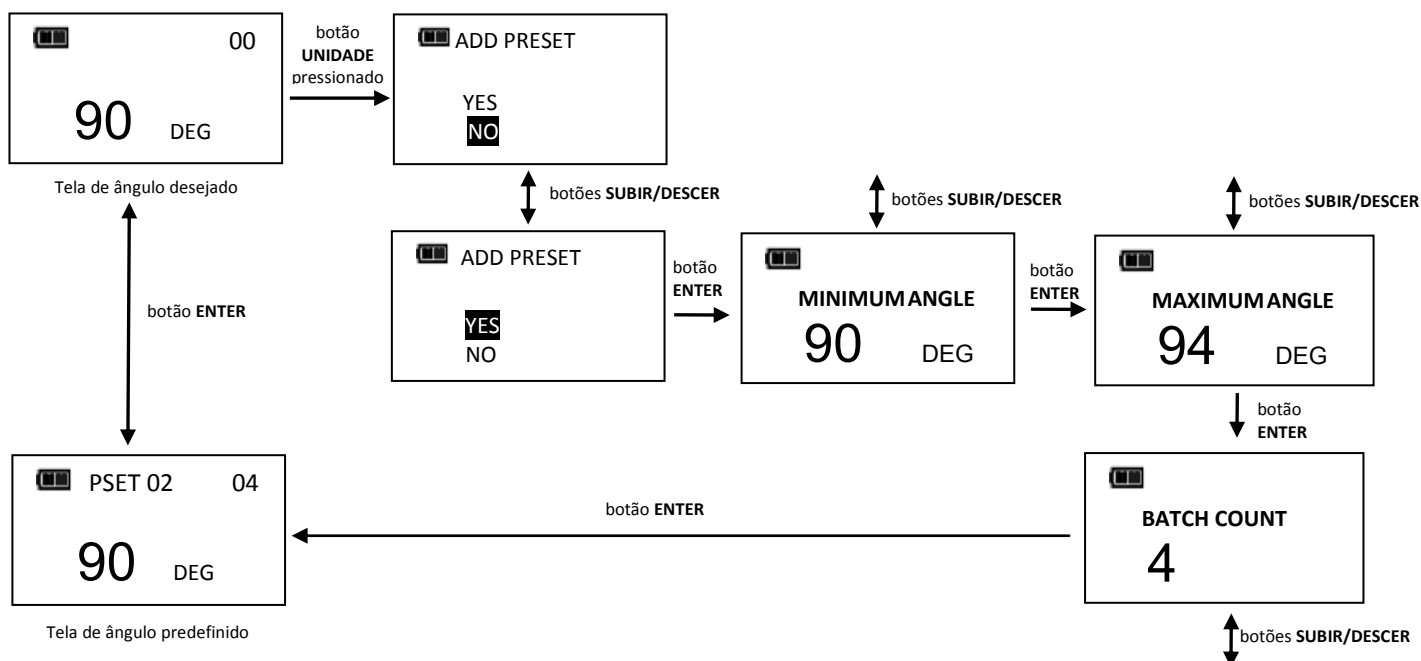

*Obs.: Para selecionar um valor PSET armazenado ou o modo de torque ou ângulo desejado manual, aperte repetidamente o botão **ENTER ↵** até que o valor PSET ou o modo manual seja exibido.*

### **Editar um valor predefinido**

A função de edição de PSET permite que o usuário edite os valores predefinidos armazenados no torquímetro.

- Na tela do valor predefinido que deseja editar, aperte e segure o botão **UNIDADE U** por 3 segundos.
- A tela CHANGE PRESET (alterar valor predefinido) é exibida.
- Selecione a opção **EDIT** usando os botões **SUBIR ▲** / **DESCER ▼** e, então, aperte o botão **ENTER ↵**.
- A tela MINIMUM TORQUE ou MINIMUM ANGLE é exibida. O valor pode ser alterado apertando os botões **SUBIR ▲** / **DESCER ▼**. Depois de definir o valor de torque ou ângulo desejado, aperte o botão **ENTER ↵**.
- A tela MAXIMUM TORQUE ou MAXIMUM ANGLE é exibida a seguir. O valor pode ser alterado apertando os botões **SUBIR ▲** / **DESCER ▼**. Depois de definir o valor de torque ou ângulo desejado, aperte o botão **ENTER ↵**.
- A tela BATCH COUNT (contagem de lotes) é exibida a seguir. O valor pode ser alterado apertando os botões **SUBIR ▲** / **DESCER ▼**. Depois de definir o valor de contagem de lotes desejado, aperte o botão **ENTER ↵**.
- A tela de PSET desejado é exibida com o mesmo número de PSET.



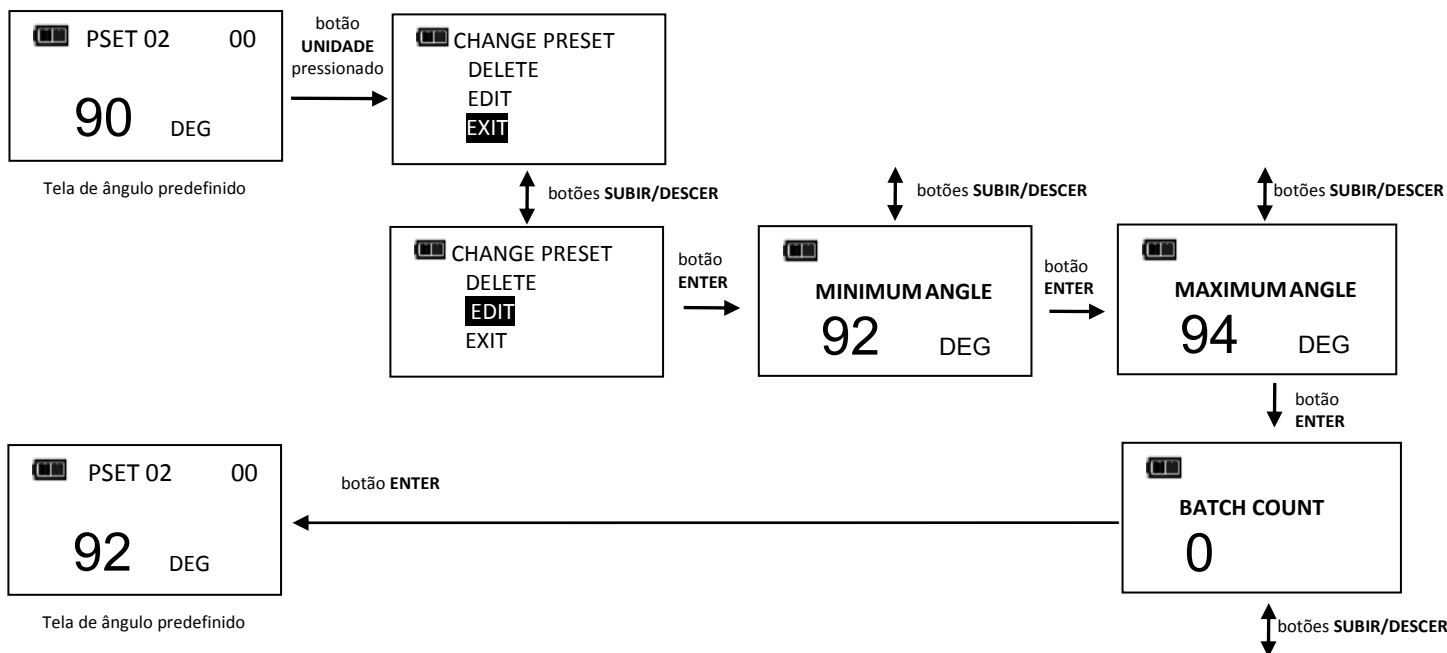

Obs.: Apertar o botão **ENTER** com a opção de menu **EXIT** selecionada faz com que você saia sem editar o PSET.

### Excluir um valor predefinido

A função de excluir um PSET permite ao usuário remover valores predefinidos armazenados no torquímetro.

1. Na tela do valor predefinido que será excluído, aperte e segure o botão **UNIDADE U** por 3 segundos.
2. A tela CHANGE PRESET (alterar valor predefinido) é exibida.
3. Selecione a opção de menu **DELETE** usando os botões **SUBIR ▲**/**DESCER ▼** e aperte o botão **ENTER**.
4. A tela de valor desejado é exibida e o valor predefinido excluído não estará mais disponível para seleção.

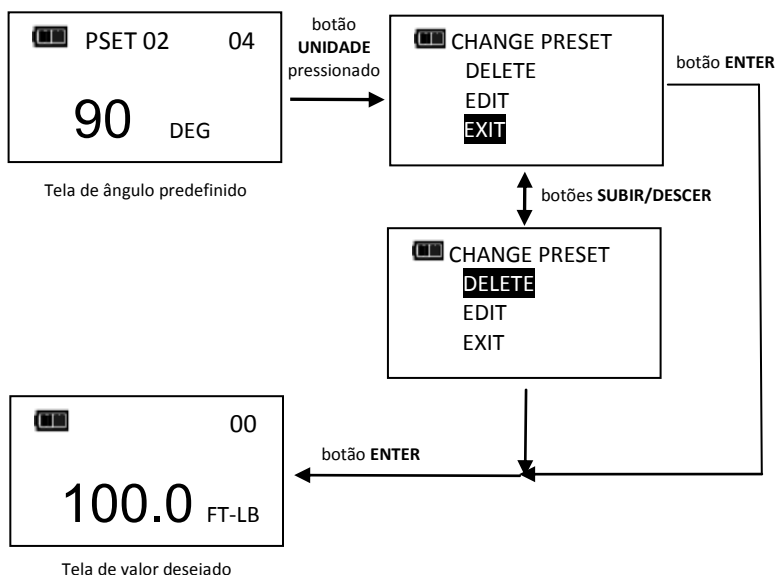

Obs.: Apertar o botão **ENTER** com a opção de menu **EXIT** selecionada faz com que você saia sem excluir o PSET.

Obs.: Quando um PSET é excluído, todos os valores predefinidos armazenados mantêm seus números de PSET originais. Ao inserir um novo PSET, este será o primeiro número de PSET ao dispor na sequência.

## Definições avançadas

### Acessar as definições avançadas

As definições avançadas são acessadas pela opção **SETTINGS** no menu principal.

1. Na tela de torque ou ângulo desejado, aperte e segure o botão **ENTER** por 3 segundos.
2. Selecione a opção de menu **SETTINGS** usando os botões **SUBIR** /**DESCER** .
3. Aperte o botão **ENTER** para exibir o menu Settings (definições).

Opções de menu:

- **EXIT**: fecha o menu Settings e volta à tela de valor desejado.
  - **SHOW INFO**: exibe informações operacionais do torquímetro.
  - **SLEEP TIME**: exibe a tela de ajuste do tempo de desligamento automático.
  - **LCD CONTRAST**: exibe a tela de ajuste do contraste do LCD.
  - **KEY BEEP**: exibe a tela para ativar/desativar o bipe ao apertar um botão.
  - **AUTO BACKLIGHT**: exibe a tela para ativar/desativar a iluminação automática quando se faz uma medição.
  - **TOGGLE BACKLIGHT**: exibe a tela para ativar/desativar a função liga/desliga do botão **ILUMINAÇÃO** .
  - **VIBRATOR CONFIG**: exibe a opção de LIGAR/DESLIGAR a vibração ao chegar ao valor desejado.
4. Para sair do menu Settings e voltar à tela de torque ou ângulo desejado, aperte o botão **ENTER** com a opção de menu **EXIT** selecionada.

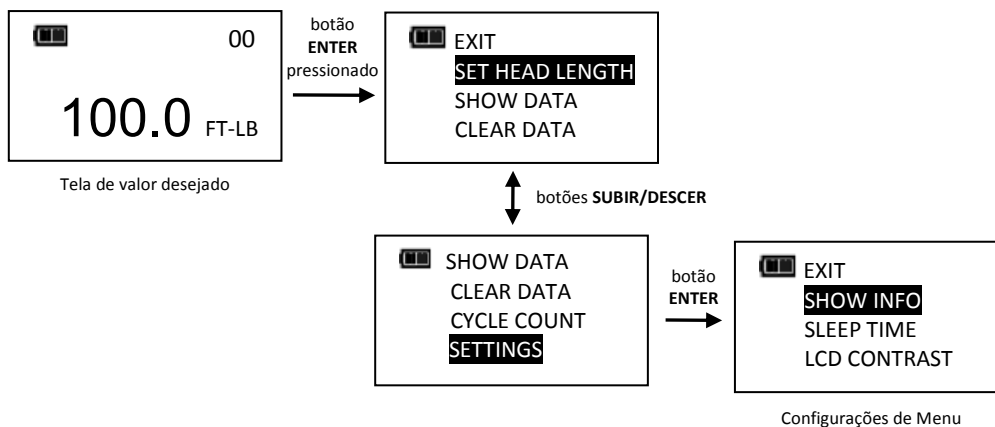

*Obs.: Todas as definições passíveis de alteração pelo usuário são armazenadas na memória não volátil e mantidas enquanto o aparelho está desligado.*

### Mostrar informações

A opção de menu Show Info (mostrar informações) exibe as informações operacionais do torquímetro.

1. No menu Settings, aperte o botão **ENTER** com a opção **SHOW INFO** selecionada.
2. A tela SHOW INFO (mostrar informações) é exibida.
3. **SUBIR** /**DESCER** são usados para rolar a tela.

Informações operacionais:

- **CAL**: data da última calibragem do torquímetro.
  - **ISD**: data de início de serviço.
  - **TCF**: fator de calibragem de torque.
  - **ACF**: fator de calibragem de ângulo.
  - **VER**: versão do software.
  - **OVR CNT**: o contador de torque excessivo acompanha quantas vezes um evento de torque excessivo aconteceu no torquímetro (torque maior que 125% da escala total).
  - **TQZ**: compensação de torque zero.
  - **ANZ**: compensação de ângulo zero.
4. Apertar o botão **ENTER** faz com que você deixe a tela Show Info e volte ao menu Settings.

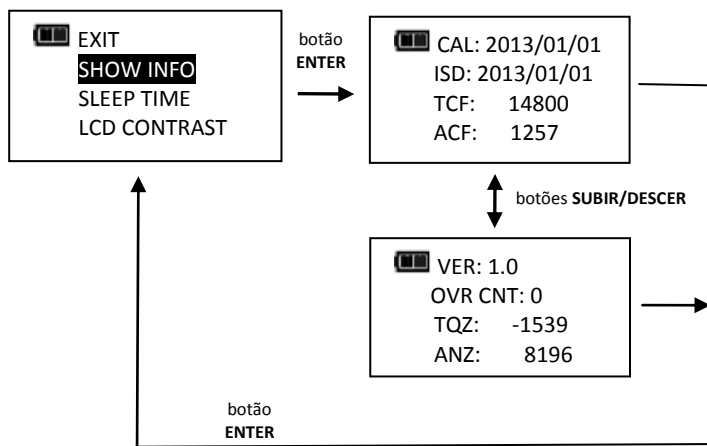

### Definição do tempo de desligamento automático

Esta função permite ao usuário definir o intervalo de tempo para que o torquímetro assuma a condição desligada desde a última vez que se aplicou torque ou apertou um botão.

1. No menu Settings, utilize os botões **SUBIR ▲**/**DESCER ▼** para selecionar a opção **SLEEP TIME** e, então, aperte o botão **ENTER ↵**.
2. A tela SLEEP TIME (tempo de desligamento automático) é exibida.
3. Utilize os botões **SUBIR ▲**/**DESCER ▼** para selecionar o tempo de desligamento automático.

Intervalos de tempo selecionáveis:

- 2 MIN (padrão de fábrica)
- 5 MIN
- 10 MIN
- 30 MIN
- 1 HR
- 2 HR
- 8 HR

4. Aperte o botão **ENTER ↵** para aceitar a seleção e voltar ao menu Settings.

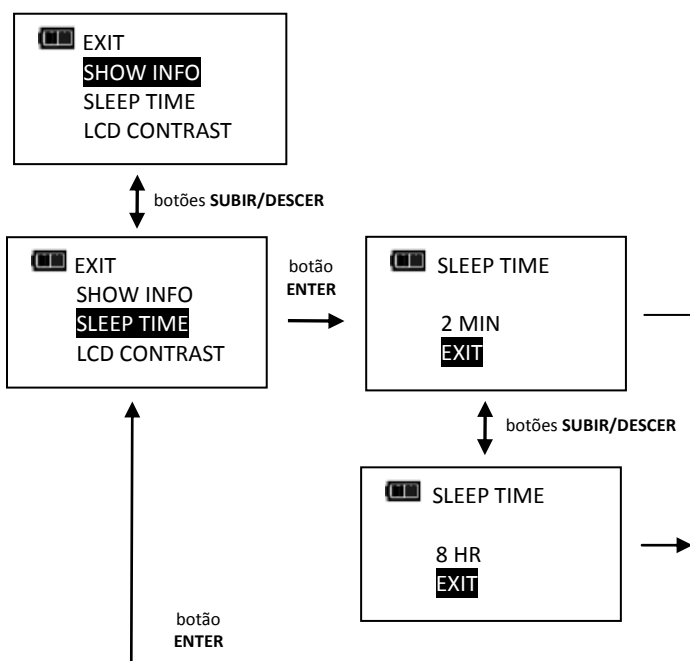

### Definição do contraste do LCD

Esta função permite que o usuário defina o contraste do LCD a fim de otimizar a visualização.

1. No menu Settings, utilize os botões **SUBIR ▲**/**DESCER ▼** para selecionar a opção **LCD CONTRAST** e, então, aperte o botão **ENTER ↵**.
2. A tela CONTRAST (contraste) é exibida.
3. Utilize os botões **SUBIR ▲**/**DESCER ▼** enquanto observa o visor para ajustar o contraste ao nível desejado.





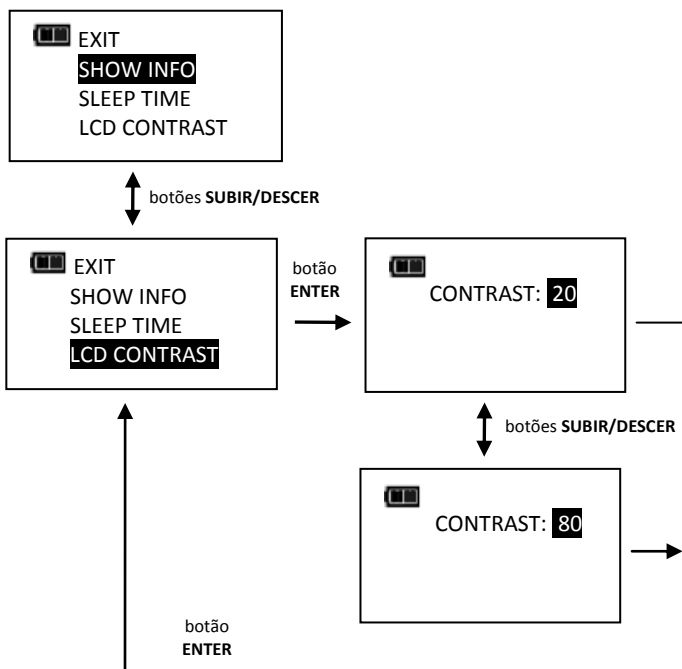

Níveis selecionáveis: 20 a 80 em incrementos de 5 (padrão de fábrica = 40).

- Aperte o botão **ENTER**  para aceitar a seleção e voltar ao menu Settings.



### Ajuste do bipe das teclas





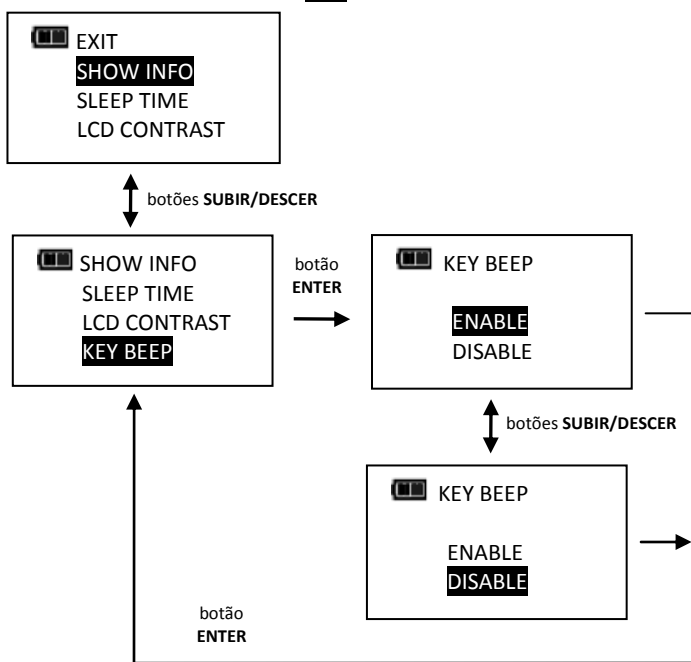

Esta função permite ao usuário ativar ou desativar a resposta sonora ao apertar um botão.

- No menu Settings, utilize os botões **SUBIR** /**DESCER**  para selecionar a opção **KEY BEEP** e, então, aperte **ENTER** .
- A tela KEY BEEP (bipe das teclas) é exibida.
- Utilize os botões **SUBIR** /**DESCER**  para destacar a opção **ENABLE** (ativar) (padrão de fábrica) ou **DISABLE** (desativar).
- Aperte o botão **ENTER**  para aceitar a seleção e voltar ao menu Settings.



### Ajuste da iluminação automática

Esta função permite ao usuário ativar ou desativar a iluminação durante as medições de torque ou ângulo.

- No menu Settings, utilize os botões **SUBIR** /**DESCER**  para selecionar a opção **AUTO BACKLIGHT** e, então, aperte o botão **ENTER** .
- A tela AUTO BACKLIGHT (iluminação automática) é exibida.
- Utilize os botões **SUBIR** /**DESCER**  para selecionar a opção **ENABLE** (ativar) (padrão de fábrica) ou **DISABLE** (desativar).
- Aperte o botão **ENTER**  para aceitar a seleção e voltar ao menu Settings.

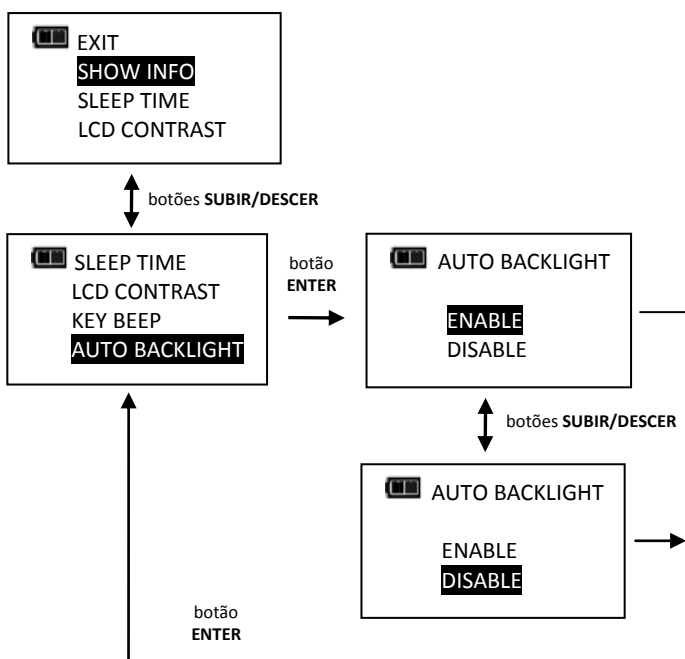

### Ajuste da função liga/desliga da iluminação

Esta função permite ao usuário ativar ou desativar a função liga/desliga da iluminação. Se o modo liga/desliga estiver desativado, o botão **ILUMINAÇÃO** acenderá a luz de fundo e esta se apagará automaticamente cinco segundos depois de apertar qualquer botão. Se o modo liga/desliga estiver ativado, apertar o botão **ILUMINAÇÃO** acenderá a luz de fundo e ela permanecerá acesa até apertar novamente o botão **ILUMINAÇÃO** .

1. No menu Settings, utilize os botões **SUBIR** /**DESCER** para selecionar a opção **TOGGLE BACKLIGHT** e, então, aperte o botão **ENTER** .
2. A tela TOGGLE BACKLIGHT (função liga/desliga da iluminação) é exibida.
3. Utilize os botões **SUBIR** /**DESCER** para selecionar a opção **ENABLE** (ativar) ou **DISABLE** (desativar) (padrão de fábrica).
4. Aperte o botão **ENTER** para aceitar a seleção e voltar ao menu Settings.

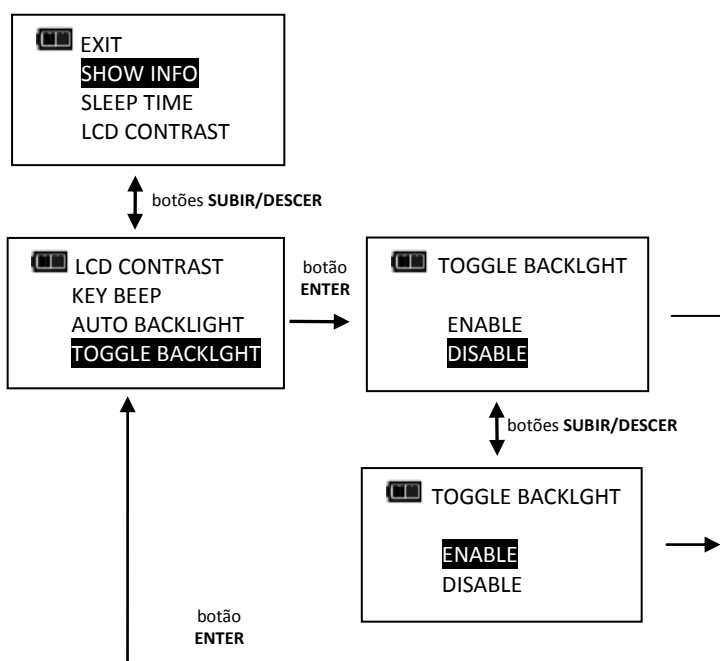

*Obs.: A luz de fundo desligará quando o torquímetro for desligado ao apertar o botão **LIGA/DESLIGA** ou quando o tempo de desligamento automático for atingido.*

*Obs.: Se a função liga/desliga da iluminação estiver ativada e a luz de fundo estiver acesa, esta permanecerá acesa durante e após a aplicação de torque.*

## Configuração da vibração

Esta função permite ao usuário configurar a vibração como Ligada ou Desligada quando o valor desejado é alcançado, por motivos de preferência e/ou para economizar a carga das pilhas.

1. No menu Settings, utilize os botões **SUBIR ▲**/**DESCER ▼** para selecionar a opção **VIBRATOR CONFIG** e, então, aperte o botão **ENTER ↵**.
2. A tela VIBRATOR CONFIG (configuração da vibração) é exibida.
3. Utilize os botões **SUBIR ▲**/**DESCER ▼** para alternar entre as opções ON e OFF.
4. Aperte o botão **ENTER ↵** para aceitar a seleção e voltar ao menu Settings.

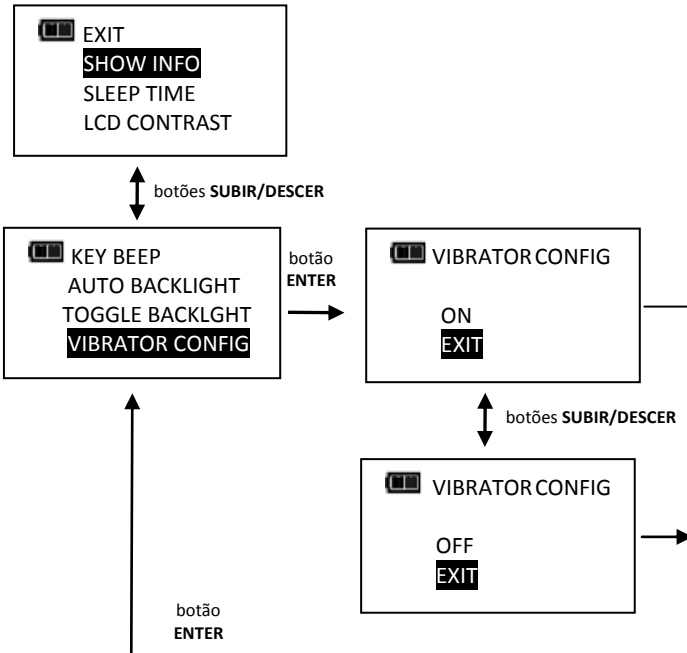

## • Configuração avançada

### Acesso à configuração avançada

A configuração avançada é acessada pela opção **CONFIGURE** no menu principal.

1. Na tela de torque ou ângulo desejado, aperte e segure o botão **ENTER ↵** por 3 segundos.
2. Selecione a opção de menu **CONFIGURE** usando os botões **SUBIR ▲**/**DESCER ▼**.
3. Aperte o botão **ENTER ↵** para exibir o menu Configure.

Opções de menu:

- EXIT: fecha o menu Configure e volta à tela de torque ou ângulo desejado.
  - MODE SETUP: exibe o menu de configuração de modo do torquímetro.
  - CALIBRATION: exibe o menu de calibragem do torquímetro (protegido por senha).
  - SET DATE/TIME: exibe as telas de ajuste de data e hora.
  - SET CAL INTRVAL: exibe a tela de ajuste do intervalo de calibragem (requer o ajuste da data e hora do relógio).
4. Para sair do menu Configure e voltar à tela de torque ou ângulo desejado, aperte o botão **ENTER ↵** com a opção de menu **EXIT** selecionada.

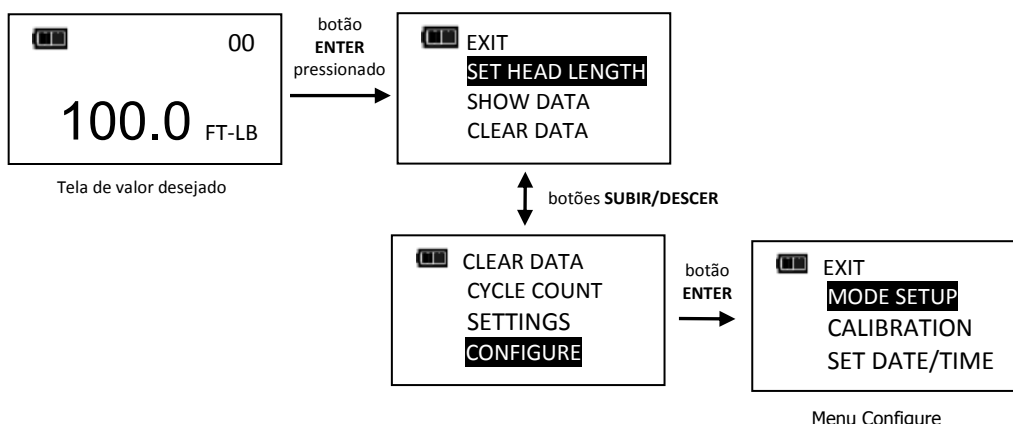

Obs.: Todas as definições passíveis de alteração pelo usuário são armazenadas na memória não volátil e mantidas enquanto o aparelho está desligado.

## Configuração de modo

O menu Mode Setup permite ao usuário ativar/desativar o modo Torque THEN angle (torque DEPOIS ângulo).

1. No menu Configure, aperte o botão **ENTER** com a opção **MODE SETUP** selecionada.
2. O menu Mode Setup (configuração de modo) é exibido.

Opções de menu:

- EXIT: fecha o menu Mode Setup e volta à tela de menu Configure.
  - THEN DISABLED: exibe a tela para ativar/desativar o modo THEN.
3. Utilize os botões **SUBIR** /**DESCER** para selecionar as opções de menu.
  4. Apertar o botão **ENTER** com a opção de menu **EXIT** selecionada faz com que você volte ao menu Configure.

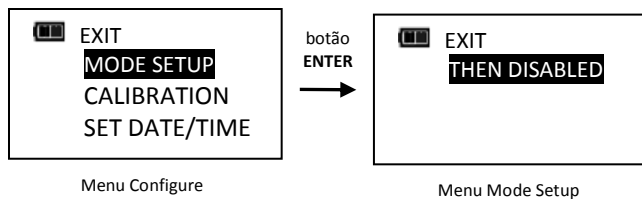

## Ativar/Desativar o modo de Torque DEPOIS Ângulo

Esta função permite ao usuário ativar ou desativar o modo Torque THEN Angle (torque DEPOIS ângulo).

1. No menu Mode Setup, utilize os botões **SUBIR** /**DESCER** para selecionar a opção **THEN DISABLED** (padrão de fábrica) e, então, aperte o botão **ENTER** .
2. A tela para ativar/desativar o modo TQ THEN ANGLE (torque DEPOIS ângulo) é exibida.
3. Utilize os botões **SUBIR** /**DESCER** para selecionar a opção **ENABLE** (ativar) ou **DISABLE** (desativar).
4. Aperte o botão **ENTER** para aceitar a seleção e voltar ao menu Mode Setup.

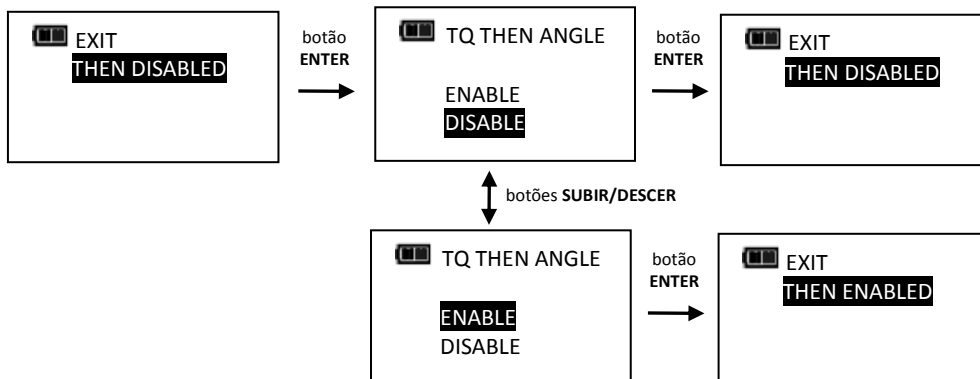

Obs.: A opção de menu indica a configuração atual (ENABLED ou DISABLED).

## Modo torque DEPOIS ângulo

Antes de selecionar o modo Torque THEN Angle (torque DEPOIS ângulo), deve-se definir um torque desejado, a unidade e um ângulo desejado. No modo Torque THEN Angle, quando o torque aplicado chega ao torque desejado, o torquímetro alterna automaticamente para o modo de ângulo para medir o ângulo. As luzes de progresso indicam o progresso do torque aplicado enquanto este é medido, e do ângulo quando o ângulo é medido.

1. Na tela de torque desejado, utilize os botões **SUBIR** /**DESCER** para definir o torque desejado e o botão **UNIDADE** **U** para selecionar a unidade de medida do torque e, então, aperte o botão **ENTER** .
2. A tela de ângulo desejada é exibida. Utilize os botões **SUBIR** /**DESCER** para definir o ângulo desejado e, então, aperte o botão **ENTER** .
3. A tela Torque THEN Angle (torque DEPOIS ângulo) é exibida.
4. Aplique torque até chegar ao valor desejado e, então, gire o torquímetro ao ângulo desejado.

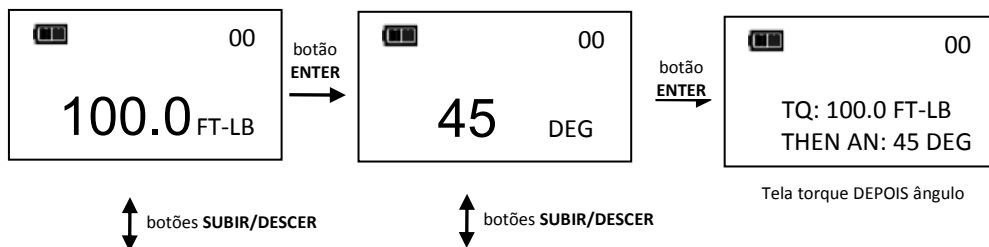

*Obs.: O botão **UNIDADE U** pode ser usado para selecionar a unidade de torque na tela Torque THEN Angle.*

*Obs.: Os valores predefinidos para o modo Torque THEN Angle são inseridos apertando e segurando o botão UNIDADE enquanto na tela Torque THEN Angle. Consulte "Adicionar um valor de torque predefinido" e "Adicionar um valor de ângulo predefinido" na seção Funções básicas para inserir parâmetros.*

*Obs.: O ciclo de torque só é registrado na memória se ambos o torque desejado e o ângulo desejado forem atingidos.*

*Obs.: As luzes de progresso vermelha e amarela acendem se o torque ultrapassa 110% da escala total do torquímetro ou se o ângulo ultrapassa o valor desejado mais 4% no modo manual.*

*Obs.: As luzes de progresso vermelha e amarela acendem se o torque ultrapassa o torque máximo e se o ângulo ultrapassa o ângulo máximo no modo Preset.*

### **Calibragem**

O menu de calibragem é protegido por senha. Entre em contato com sua Central de Reparo local da Snap-on para se informar sobre o menu de calibragem.

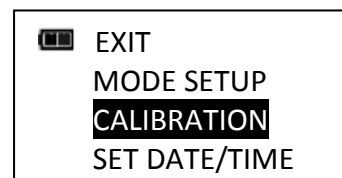

### **Ajuste de data e hora**

A função Set Date/Time permite ao usuário definir a data e hora reais a fim de registrar dados com marcação de tempo, registrar a data da última calibragem e notificar ao usuário se o intervalo de tempo para calibragem expirou.

*Obs.: Quando a data e a hora são definidos pela primeira vez, a data de início de serviço também é definida e é usada para calcular o intervalo de calibragem inicial (consulte "Definição de intervalo de calibragem" na seção Configuração avançada).*

1. No menu Settings, utilize os botões **SUBIR ▲**/**DESCER ▼** para selecionar a opção **SET DATE/TIME** e, então, aperte o botão **ENTER ↵**.
2. A tela SET DATE (definir data) é exibida com o ano destacado.
3. Utilize os botões **SUBIR ▲**/**DESCER ▼** para definir o ano e, então, aperte o botão **ENTER ↵** para selecionar o mês.
4. Utilize os botões **SUBIR ▲**/**DESCER ▼** para definir o mês e, então, aperte o botão **ENTER ↵** para selecionar o dia.
5. Utilize os botões **SUBIR ▲**/**DESCER ▼** para definir o dia e, então, aperte o botão **ENTER ↵**.
6. A tela SET TIME (definir hora) é exibida com o hora destacada.
7. Utilize os botões **SUBIR ▲**/**DESCER ▼** para definir a hora e, então, aperte o botão **ENTER ↵** para selecionar os minutos.
8. Utilize os botões **SUBIR ▲**/**DESCER ▼** para definir os minutos e, então, aperte o botão **ENTER ↵** para selecionar os segundos.
9. Utilize os botões **SUBIR ▲**/**DESCER ▼** para definir os segundos e, então, aperte o botão **ENTER ↵**.
10. O relógio está ajustado e o menu Configure é exibido.



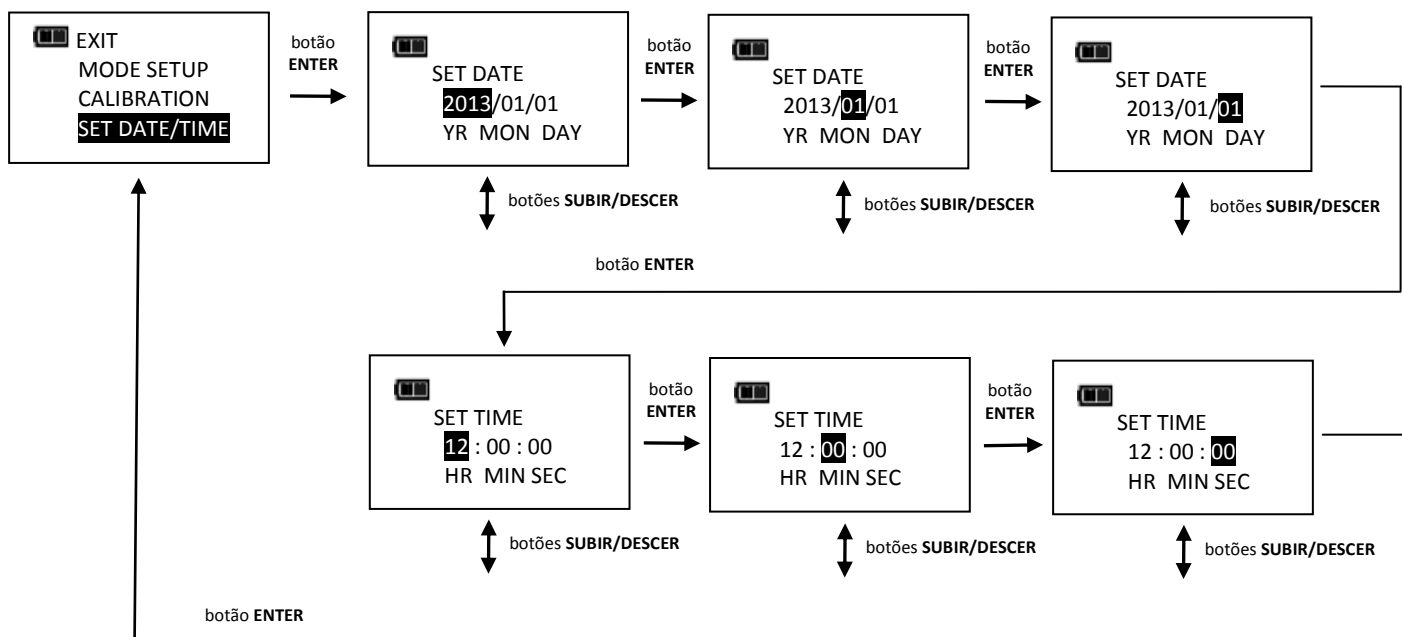

Obs.: A opção de ano começará a partir de 2013. A opção de mês será de 1 a 12. A opção de dia será de 1 a 31.

Obs.: A opção de hora será de 0 a 23. As opções de minutos e segundos serão de 0 a 59.

Obs.: Se as baterias forem removidas do torquímetro por mais de 20 minutos, o relógio voltará às definições padrão e deverá ser regulado novamente ao ligar a ferramenta.

### Definição de intervalo de calibragem

Esta função permite ao usuário definir o intervalo de calibragem para quando a mensagem "CAL NEEDED" (calibragem necessária) será exibida.

- No menu Settings, utilize os botões **SUBIR ▲**/**DESCER ▼** para selecionar a opção **SET CAL INTRVAL** e, então, aperte o botão **ENTER ↵**.
- A tela CAL INTERVAL (intervalo de calibragem) é exibida.
- Utilize os botões **SUBIR ▲**/**DESCER ▼** para alterar o intervalo de calibragem.

Intervalos de tempo selecionáveis:

- DISABLED (desativado) (padrão de fábrica)
- 3 MON
- 6 MON
- 12 MON

- Aperte o botão **ENTER ↵** para aceitar a seleção e voltar ao menu Configure.

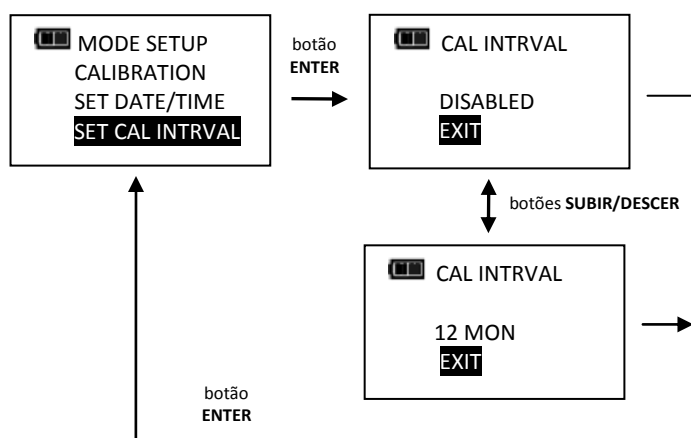

Obs.: A data e hora do relógio devem ser ajustados para que o intervalo de calibragem funcione. Se as baterias forem removidas do torquímetro por mais de 20 minutos, o relógio voltará às definições padrão e deverá ser regulado novamente ao ligar a ferramenta.







Obs.: O intervalo de calibragem é calculado com base na data de início de serviço ou com base na última data de calibragem (consulte o menu SHOW INFO), dependendo de qual é a mais recente. Quando a data do relógio for maior que a data de início de serviço ou que a data da





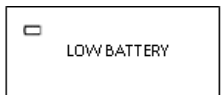

última calibragem mais o intervalo de calibragem, a mensagem "CAL NEEDED" (calibragem necessária) será exibida ao ligar a ferramenta e após uma redefinição para zero. Aperte o botão **ENTER**  para avançar ao menu de valor desejado. Aplicar torque enquanto a mensagem "CAL NEEDED" é exibida fará com que a medição de torque ou ângulo seja exibida imediatamente e você voltará ao menu de valor desejado quando o torque for liberado.

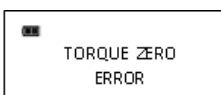
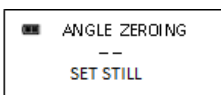
Obs.: Como alternativa ao intervalo de calibragem, foi incluído um Contador de Ciclos de Calibragem no menu de calibragem (entre em contato com sua Central de Reparo local da Snap-on para se informar sobre esse menu).

## • Solução de problemas

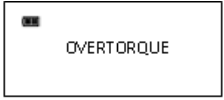
Obs.: Se algum dos problemas a seguir persistir, leve o torquímetro a uma central de reparo autorizada da Snap-on.

Problema	Possível causa	Solução
O torquímetro não liga quando apertado o botão <b>LIGA/DESLIGA</b> 	Pilhas descarregadas/sem pilhas	Troque as pilhas
	Erro de software	Retire as pilhas e as recoloque para reiniciar a corrente
Leitura de torque fora das especificações	Necessária calibragem	Recalibrar
	Comprimento de cabeça inserido incorreto	Insira o comprimento de cabeça de compensação certo
O torquímetro não mantém as definições quando as pilhas são removidas	Pilhas removidas antes de salvar as definições na memória não volátil	Insira novamente as definições e aperte e segure o botão <b>LIGA/DESLIGA</b>  para desligar o torquímetro antes de remover as pilhas
Torque ou ângulo exibidos sem aplicar torque	Torque ou ângulo zerados durante aplicação de torque	Posicione o torquímetro sobre uma superfície estável sem aplicar torque e aperte o botão <b>LIGA/DESLIGA</b>  para zerar o torquímetro
	Bateria fraca	Aperte o botão <b>ENTER</b>  para continuar usando o torquímetro e troque as pilhas o mais rápido possível
	Bateria descarregada	Aperte o botão <b>LIGA/DESLIGA</b>  para desligar o torquímetro e troque as pilhas
	Torque aplicado enquanto o torquímetro era zerado	Remova o torque e zere o torquímetro
	Torque excessivo aplicado ao torquímetro	Recalibrar
	Torquímetro calibrado incorretamente	Recalibrar
	Erro no sensor de torque	Leve o torquímetro a uma Central de Reparo Snap-on
	Torquímetro movido durante a redefinição para zero	Posicione o torquímetro sobre uma superfície estável
	Giroscópio instável	Leve o torquímetro a uma Central de Reparo Snap-on

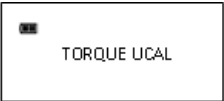
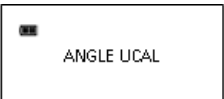
Problema	Possível causa	Solução
	Botão <b>LIGA/DESLIGA</b>  pressionado ao zerar o ângulo (redefinição a zero cancelada para acessar menus)	Coloque o torquímetro sobre uma superfície estável e aperte o botão <b>LIGA/DESLIGA</b>  para zerar o torquímetro
	Torque aplicado superior a 125% da escala total	Desligue e ligue usando o botão <b>LIGA/DESLIGA</b>  e recalibre
	Torquímetro girado muito rapidamente durante a medição do ângulo	Coloque o torquímetro sobre uma superfície estável e aperte o botão <b>LIGA/DESLIGA</b>  para zerar o torquímetro
	Erro na memória	Limpe a memória de dados
	Torque descalibrado	Calibre o torque
	Ângulo descalibrado	Calibre o ângulo

## ● USO DE ADAPTADORES, EXTENSÕES E ACESSÓRIOS UNIVERSAIS

Sempre que um adaptador, extensão ou acessório universal for usado com um torquímetro de modo que a distância da peça de fixação seja diferente da distância do encaixe quadrado do torquímetro durante a calibragem, é necessário ajustar o comprimento de cabeça para obter uma leitura correta do torque da peça de fixação.

Ao utilizar uma extensão incomum ou um acessório universal, não ultrapasse mais que 15 graus de deslocamento do encaixe perpendicular. Não utilize uma extensão longa com um encaixe totalmente flexionado.

## ● CALIBRAGEM

Entre em contato com seu representante de vendas da Snap-on para serviços de calibragem.

## ● CERTIFICADO

Este torquímetro TechAngle<sup>®</sup> foi calibrado na fábrica usando instrumentos de medição de torque e deslocamento angular que cumprem com as normas do National Institute of Standards and Technology (N.I.S.T.). Os parâmetros de torque estão de acordo com os padrões ISO 6789-2003 e ASME B107-28-2010. Obs.: não existe nenhum padrão internacional nem nos Estados Unidos para chaves de ângulo.

**IMPORTANT!** Calibration events are recorded in wrench memory which provides evidence to void factory certification.

## ● MANUTENÇÃO / SERVIÇO

Limpe o torquímetro com um pano úmido. NÃO utilize solventes, diluentes nem produtos de limpeza para carburadores.

NÃO mergulhe o torquímetro em líquido algum.

A manutenção, reparo e calibragem só devem ser realizados nas centrais de serviço da Snap-on. Entre em contato com seu representante Snap-on Tools.

O reparo da cabeça de catraca pode ser realizado por um representante Snap-on ou pelo usuário.

## ● Troca das pilhas

**Troque somente por três pilhas "AA".**

- Não tente recarregar as pilhas alcalinas.
- Não misture diferentes tipos de pilha.
- Troque todas as pilhas ao mesmo tempo.
- Guarde o torquímetro em local seco.
- Remova as pilhas quando for guardar o torquímetro sem utilizá-lo por mais que 3 meses.

*Obs.: Quando for trocar as pilhas, o relógio manterá a data e a hora por 20 minutos.*

*Obs.: Gire a tampa no sentido anti-horário para soltá-la.*

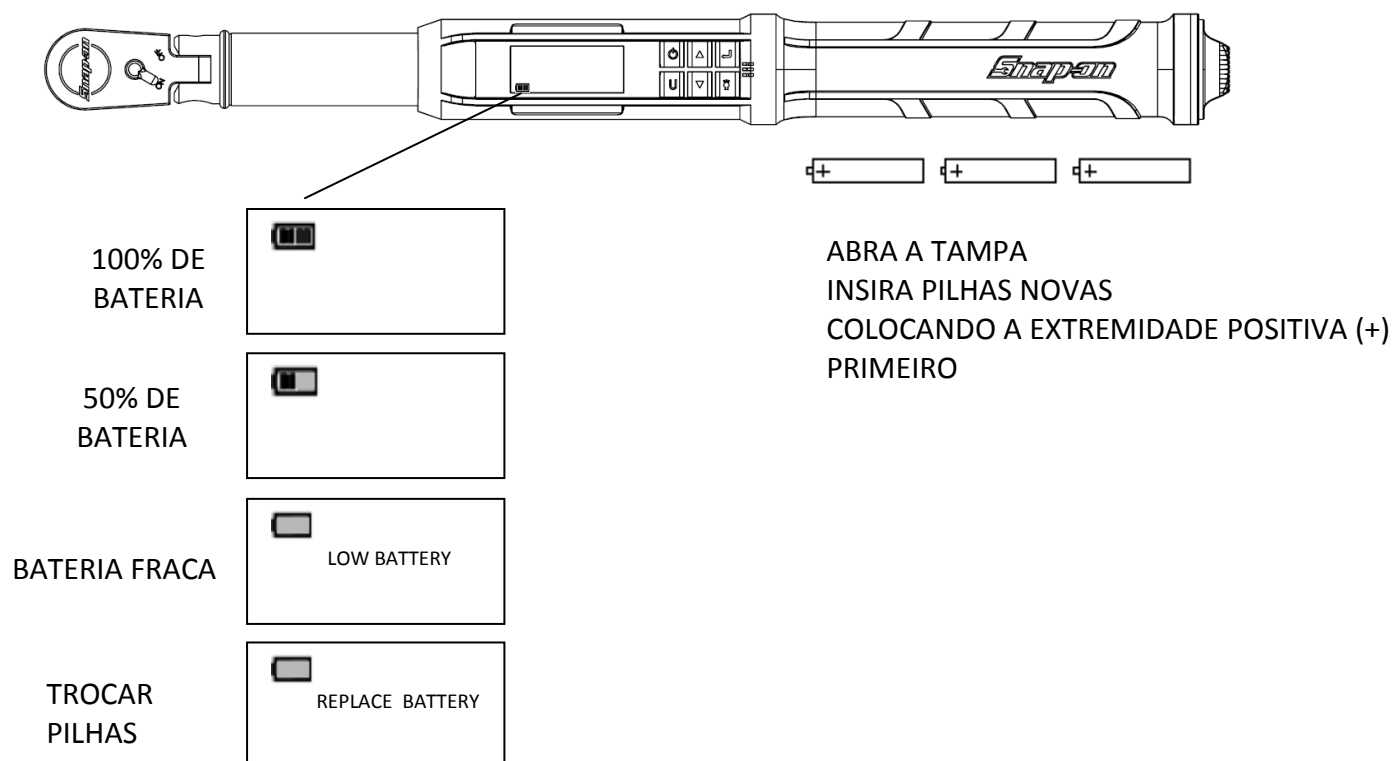

*Obs.: Quando a tela Replace Battery for exibida, o torqueímetro não funcionará mais até que as pilhas sejam trocadas. Somente o botão **LIGA/DESLIGA**  funcionará, o qual desligará o torqueímetro imediatamente.*

## ● Indicadores de memória

DADOS NA  
MEMÓRIA

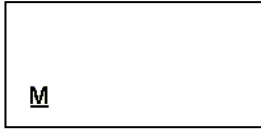

Menos de 50 registros de torque e ângulo armazenados na memória.

MEMÓRIA  
CHEIA

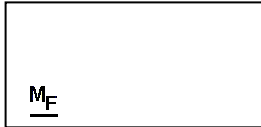

50 registros de torque ou ângulo armazenados na memória. O registro mais antigo será substituído pelo próximo registro.

ERRO DE  
MEMÓRIA

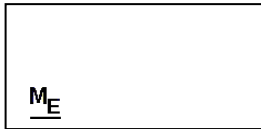

Erro de leitura ou gravação na memória. Leve o torquímetro a uma Central de Reparo Snap-on se o erro persistir após a limpeza da memória.

# CENTRAIS DE REPARO AUTORIZADAS DA SNAP-ON

## EUA

**Eastern Repair Center**  
6320 Flank Drive  
Harrisburg, PA 17112  
Telefone: 717-652-7914  
Fax: 717-652-7123

**Northern Repair Center**  
3011 E. State Rt. 176, Dock A  
Crystal Lake, IL 60014  
Telefone: 815-479-6850  
Fax: 815-479-6857

**Western Repair Center**  
2151 Challenger Way  
Carson City, NV 89706-0753  
Telefone: 775-883-8585  
Fax: 775-883-8590

## CANADÁ

**Western Repair Centre**  
7403-48 Street SE  
Calgary, Alberta  
Canada, T2C-4H6  
Telefone: 403-720-0525  
Fax: 403-720-0524

## INTERNACIONAL

**Central de reparo do Reino Unido**  
Telford Way  
Telford Way Industrial Estate  
Kettering, Northants  
NN16 8UN England  
Telefone: 44-1-536-413855  
Fax: 44-1-536-413900

**Central de reparo da Austrália**  
Snap-on Tools Australia PTY.LTD  
Unit 6/110 Station Road  
Seven Hills, NSW 2147  
Australia  
Telefone: 61-2-8937-9155  
Fax: 61-2-9624-2445

**Central de reparo de Cingapura**  
Snap-on Tools Singapore PTE Ltd  
128 Tagore Lane, Blk 4 Singapore  
787554 Republic of Singapore  
Telefone: 011-65-451-5570  
Fax: 011-65-451-5574

**Central de reparo do Japão**  
Snap-on Tools Japan K.K.  
3-5-12 Konan  
Minato-KU, Tokyo 108  
Japão  
Telefone: 81-3-5463-1280  
Fax: 81-3-5463-1284

**Snap-on/SUN do México**  
S.A. De C.V.  
Avenida Presidente Juarez No.  
2016  
Col Los Reyes Zona Industrial  
Tlalnepantla Edo De Mexico  
CP54070 MÉXICO  
Telefone: 52-55-53903122  
Fax: 52-55-53903259

### OBSERVAÇÕES AMBIENTAIS IMPORTANTES:



1. ESTE EQUIPAMENTO PODE CONTER MATERIAIS NOCIVOS AO MEIO AMBIENTE.
2. NÃO DESCARTE ESTE EQUIPAMENTO COMO LIXO COMUM. DEVOLVA-O À DISTRIBUIDORA OU UMA CENTRAL DE COLETA INDICADA.

OBRIGADO POR CUIDAR DO NOSSO MEIO AMBIENTE!

**Snap-on Tools Company**  
Kenosha, WI 53141-1410 USA



Impresso nos EUA

# WICHTIGE SICHERHEITSHINWEISE



## **WARNUNG Gefahr von herumfliegenden Partikeln.**

Ein Überdrehen kann zum Bruch führen. Gewalt gegen Flex-Stopper am Flex-Kopf kann zum Kopfbruch führen. Ein Drehwinkelschlüssel außerhalb der Kalibrierung kann zur Beschädigung des Werkstücks oder Werkzeugs führen. Defekte Hand-Werkzeuge, Stecknüsse oder Zubehörteile können zu Verletzungen führen. Übermäßige Kraftaufwendung kann zum Abrutschen des Hahnenfuß- oder Ringschlüssels führen.

- Vor dem Gebrauch des ELEKTRONISCHEN SCHLÜSSELS ist **diese Anleitung vollständig** durchzulesen.
- Um die Genauigkeit zu gewährleisten, darf sich das Werkstück im Winkelmodus nicht bewegen.
- Zur persönlichen Sicherheit und Vermeidung von Beschädigung des Schlüssels ist ein sorgfältiger Umgang mit Werkzeugen und Befestigungsmitteln erforderlich.
- Zur Erhaltung der Genauigkeit ist eine regelmäßige Kalibrierung notwendig.
- Der Benutzer und umstehende Personen sollten Schutzbrillen tragen.**
- Sicherstellen, dass alle Komponenten einschließlich aller Adapter, Verlängerungen, Antriebsteile und Stecknüsse mindestens für die aufgewandten Drehmomente geeignet sind.
- Beim Gebrauch dieses Schraubenschlüssels sind alle Geräte-, System- und Hersteller-Warnhinweise, Vorsichtsmaßnahmen und Verfahren zu beachten.
- Eine Stecknuss der richtigen Größe für das Befestigungselement verwenden.
- Keine Stecknüsse mit Anzeichen von Verschleiß oder Rissen verwenden.
- Befestigungselemente mit abgerundeten Ecken ersetzen.
- Zur Vermeidung von Schäden am Schlüssel:** Den Schlüssel keinesfalls im ausgeschalteten Zustand verwenden. Zuerst stets den Schlüssel einschalten, damit das aufgebrachte Drehmoment gemessen wird.
  - Nicht die Taste **EIN/AUS**  betätigen, während ein Drehmoment aufgebracht wird oder der Schlüssel in Bewegung ist.
  - Den Schlüssel keinesfalls zum Losbrechen von Befestigungselementen verwenden.
  - Keine Verlängerungen, beispielsweise ein Rohr, am Griff des Schlüssels verwenden.
  - Vor Gebrauch sicherstellen, dass die Kapazität des Schlüssels für den Anwendungsfall ausreichend ist.
  - Wurde der Schlüssel fallen gelassen, muss die Kalibrierung überprüft werden.
- Sicherstellen, dass der Ratschenhebel vollständig in der richtigen Position (Richtung) arretiert ist.
- Die Kalibrierung des Schlüssels kontrollieren, falls seine Kapazität vermutlich überschritten wurde.
- Den Kopf von Flex-Kopftriebsteilen nicht mit Gewalt gegen die Anschläge drehen.
- Stets am Schlüsselgriff ziehen – nicht drücken – und einen sicheren Stand einnehmen, um nicht zu stürzen, falls eine Komponente nicht standhält.
- Die Alkalibatterien nicht wiederaufzuladen versuchen.
- Den Schlüssel an einem trockenen Ort aufbewahren.
- Die Batterien entfernen, wenn der Schlüssel länger als 3 Monate gelagert werden soll.



## **WARNUNG Gefahr eines elektrischen Schlags.**

Ein elektrischer Schlag kann zu Verletzungen führen. Der Kunststoffgriff ist nicht isoliert. Nicht an spannungsführenden Leitungen verwenden.

### **BEWAHREN SIE DIESE ANLEITUNG AUF**

### **Haftungsausschluss**

Es besteht keine Garantie für den Betrieb des TechAngle® Schlüssels in einem EU-Mitgliedstaat, wenn die Betriebsanweisungen nicht in der betreffenden Landessprache abgefasst sind. Wenden Sie sich an Snap-on, wenn eine Übersetzung benötigt wird.

# Technische Daten

## Kopfausführung

- Vierkant 72 oder 80 Zähne, versiegelt Flex

## Display

- Anzeige: Punktmatrix LCD-Display (Auflösung 192 x 65)
- Blickrichtung: 06.00
- Hintergrundbeleuchtung: Weiß (LED)

## Versiegelte Tastatur



**EIN/AUS** – Ein-/Ausschaltung und Nullstellung von Drehmoment und Winkel



**EINGABE** – Wahl der Messart und Menüeingabe



**AUF** – Erhöht die Drehmoment- und Winkeleinstellungen und zur Menünavigation



**AB** – Verringert die Drehmoment- und Winkeleinstellungen und zur Menünavigation



**EINHEITEN** – Wahl der Maßeinheit (ft-lbs, in-lbs, Nm, Kgm, Kg-cm, dNm) und Aufruf des PSET-(Voreinstell-) Menüs



**LCD-HINTERGRUNDBELEUCHTUNG** – Erleuchtet alle Bildschirme und den letzten maximalen Drehmoment- oder Winkelwert

## Funktionen

- Einstellen – Soll Drehmoment- oder Sollwinkel
- Kontrolle – Echtzeitanzeige des Drehmoment- oder Gesamtdrehwinkels mit Fortschrittleuchtanzeige
- Spitzenwerthaltung – 10 Sek. Blinken des Spitzendrehmoments oder abwechselnd des Spitzendrehmoments/Spitzendrehwinkels nach Loslassen
- Spitzenwertanzeige – Anzeige des letzten Spitzendrehmoments oder Spitzendrehmoment/Drehwinkels auf Tastendruck
- Speicher – Anzeige der letzten 50 Spitzendrehmomente oder Spitzendrehmomente/Spitzendrehwinkelmessungen

## Genauigkeit

- Temperatur: bei 22 °C
- Drehwinkel:  $\pm 1\%$  des Messwerts  $\pm 1^\circ$  bei Winkelgeschwindigkeit  $> 10^\circ/s < 180^\circ/s \pm 1^\circ$  der Prüfvorrichtung

- Drehmoment: 

	UZ	GUZ	
• Drehmoment: {	$\pm 2\%$	$\pm 3\%$	des Messwerts, 20 % bis 100 % der Gesamtskala
	$\pm 4\%$	$\pm 6\%$	des Messwerts, 10 % bis 19 % der Gesamtskala
	$\pm 8\%$	$\pm 10\%$	des Messwerts, 5 % bis 9 % der Gesamtskala

## Abmessungen: Länge/Gewicht

Modell	Länge	Gewicht
ATECH1FR240B	16,4 in.	1,9 lbs.
ATECH2FR100B	17,9 in.	2,3 lbs.
ATECH3FR250B	26,6 in.	3,7 lbs.

## Voreinstellbereich

- Drehwinkel: 0 bis 360° UZ oder GUZ (Anzeigeauflösung 1°)
- Drehmoment: (Anzeigebereich und Auflösung wie unten angegeben)

Modell	Vierkantantrieb	ft-lb	in-lbs	Nm	Kgm	kg-cm	dNm	Überlast (ft-lb)
ATECH1FR240B	¼ in.	1,00-20,00	12,0-240,0	1,36-27,12	n.z.	13,8-276,5	13,6-271,2	25
ATECH2FR100B	⅜ in.	5,0-100,0	60-1200	6,8-135,6	n.z.	69-1383	68-1356	125
ATECH3FR250B	½ in.	12,5-250,0	150-3000	16,9-339,0	1,73-34,56	n.z.	n.z.	312

**Betriebstemperatur:** -18 °C bis 54 °C

**Lagerungstemperatur:** -18 °C bis 54 °C

**Messdrift:** Drehwinkel: -0,12 Winkelgrade pro Grad C  
Drehmoment: +0,01 % vom Messwert pro Grad C

**Luftfeuchtigkeit:** Bis 90 %, kondensationsfrei

**Batterie:** Drei „AA“-Alkali-Zellen, bis zu 40 Stunden Dauerbetrieb

**Standard autom. Abschaltung:** Nach 2 Min. Nichtgebrauch - (einstellbar, s. Erweiterte Einstellungen)



# Benutzeranleitung

## • Grundfunktionen (Kurzanleitung)

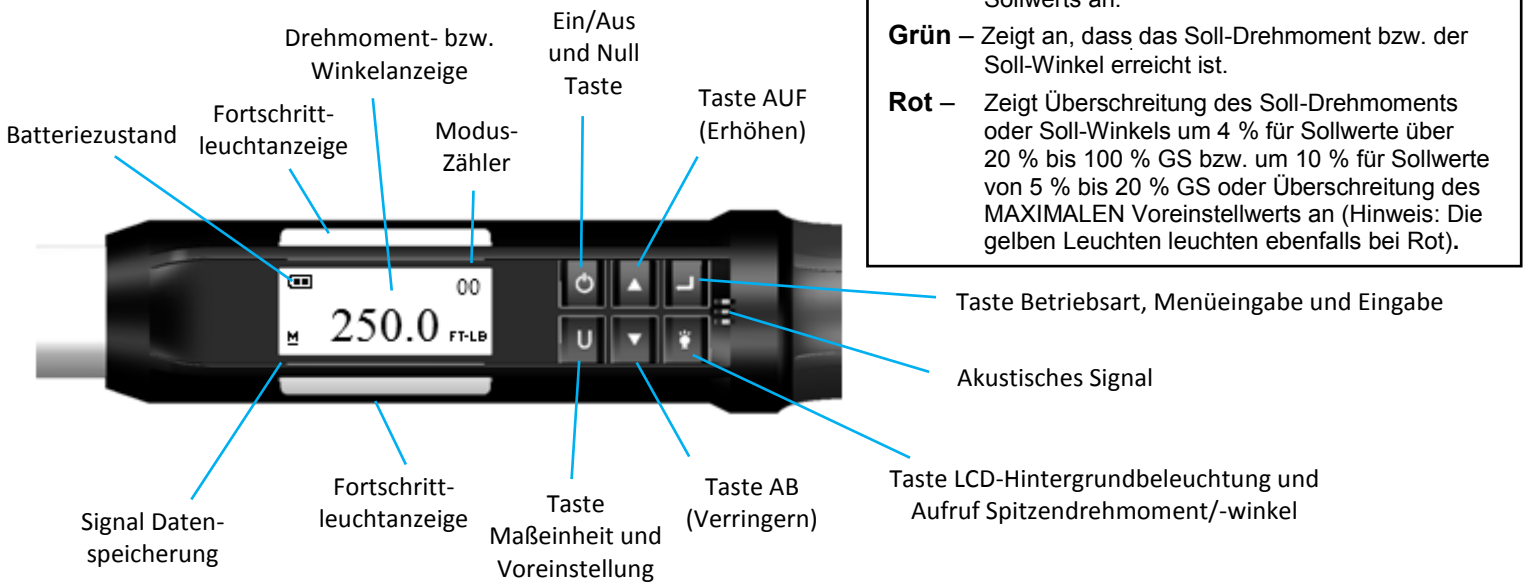

**Fortschrittleuchtanzeige**  
**Gelb** – Die erste Leuchte zeigt an, dass 40 % des Soll-Drehmoments oder Soll-Winkels erreicht sind, die zweite zeigt 60 % und die dritte 80 % des Sollwerts an.  
**Grün** – Zeigt an, dass das Soll-Drehmoment bzw. der Soll-Winkel erreicht ist.  
**Rot** – Zeigt Überschreitung des Soll-Drehmoments oder Soll-Winkels um 4 % für Sollwerte über 20 % bis 100 % GS bzw. um 10 % für Sollwerte von 5 % bis 20 % GS oder Überschreitung des MAXIMALLEN Voreinstellwerts an (Hinweis: Die gelben Leuchten leuchten ebenfalls bei Rot).

Abbildung 1

Drei frische „AA“-Batterien in den Schlüsselgriff einsetzen.

### Einschaltfolge des Schlüssels

Hinweis: Schlüssel beim Aufbringen eines Drehmoments nicht einschalten. Andernfalls kommt es zu einem falschen Drehmoment-Nullpunktversatz und der Schlüssel zeigt abschließend ein Drehmoment an. Falls dies auftritt, den Schlüssel wieder auf null stellen, indem Sie kurz die Taste **EIN/AUS** drücken, während sich der Schlüssel auf einer stabilen Oberfläche ohne Aufbringen eines Drehmoments befindet.

#### 1. Schlüssel einschalten.

Kurz die Taste **EIN/AUS** drücken. Es erscheint das Snap-on-Logo, gefolgt von der Anzeige zur Nullstellung des Drehmoments. Wurde zuletzt eine Winkelmessung vorgenommen, so folgt nach der Nullstellung des Drehmoments auch die Anzeige zur Nullstellung des Winkels. Nach erfolgter Nullpunkteinstellung erscheint die Soll-Drehmoment- oder Soll-Drehwinkel-Anzeige je nach dem vorherigen Messmodus.

#### 2. Messmodus wählen.

Umschalten zwischen Soll-Drehmoment (TORQUE) und Soll-Drehwinkel (ANGLE) durch wiederholtes Drücken der Taste **EINGABE** .

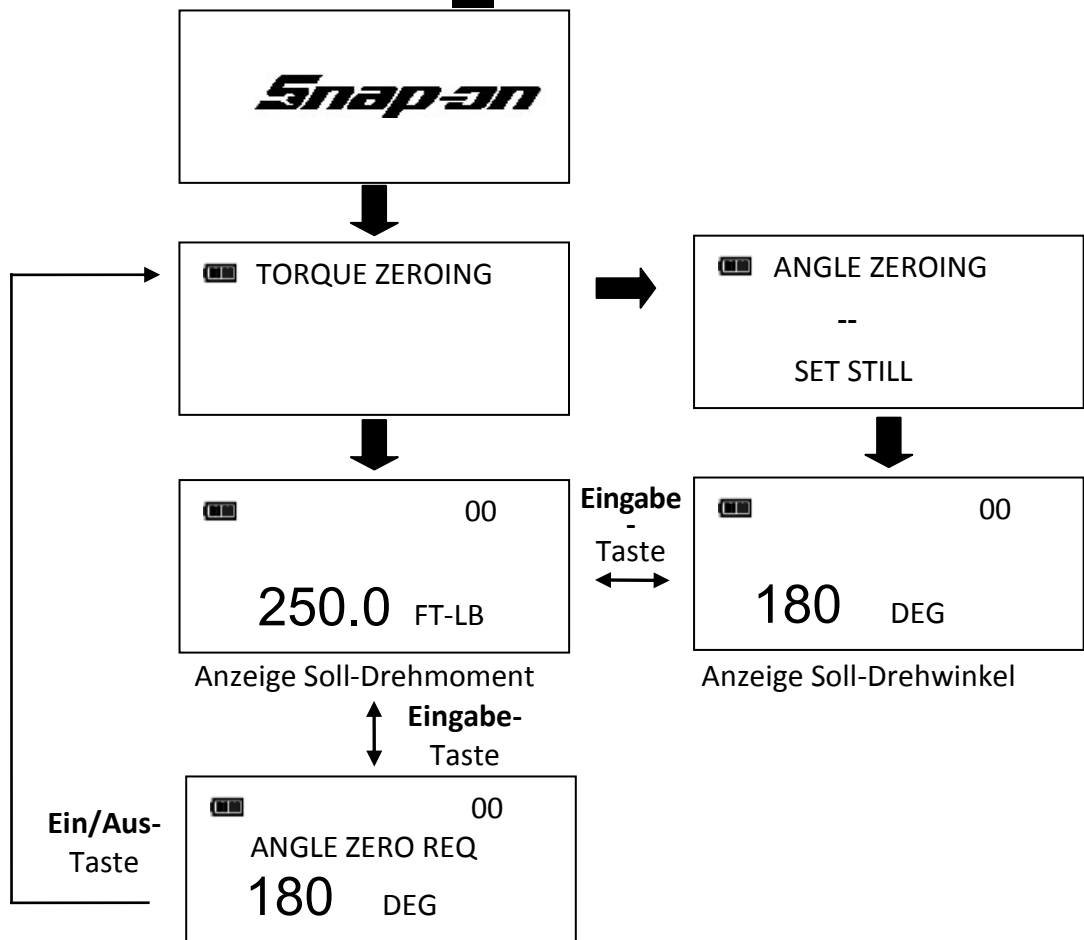

*Hinweis: Wird der Schlüssel nur im Drehmoment-Messmodus eingeschaltet, erfolgt keine Winkelnullstellung, bis der Messmodus auf Winkelmessung geändert wird, wonach die Drehmoment- und Winkelnullstellung automatisch nach 2 Sekunden beginnt. Der Schlüssel sollte auf einer stabilen Oberfläche ohne Aufbringen eines Drehmoments platziert werden.*

*Hinweis: Durch Drücken der Taste **EINGABE**  während der Winkelnullstellung wird die Nullstellfunktion abgebrochen, um dem Benutzer Gelegenheit zu geben, einen anderen Messmodus zu wählen.*

### **Drehmoment (TORQUE)-Modus**

1. Sollwert einstellen.

Den TORQUE-Sollwert mithilfe der Tasten **AUF** /**AB**  wählen.





2. Maßeinheit wählen.

Während der Anzeige TORQUE wiederholt die Taste **EINHEITEN**  drücken, bis die gewünschte Maßeinheit angezeigt wird.

3. Drehmoment aufbringen.

Den Griff in der Mitte packen (NICHT an der Batterie-Abschlusskappe ziehen) und das Befestigungselement langsam anziehen, bis die Fortschrittanzeige grün leuchtet, ½ Sekunde lang ein akustisches Signal ertönt und der Griff vibriert.

4. Keine weitere Kraft aufbringen.

Das Spitzendrehmoment blinkt nun für 10 Sekunden auf dem LCD-Display. Durch Drücken der Taste **HINTERGRUNDBELEUCHTUNG** , während das Spitzendrehmoment blinkt, bleibt die Anzeige bestehen, bis die Taste losgelassen wird. Durch kurzes Drücken der Taste **AUF** /**AB** , **EINGABE**  oder **EINHEITEN**  wird wieder das Soll-Drehmoment (TORQUE) angezeigt. Durch erneutes Festziehen eines Befestigungselements beginnt sofort eine weitere Drehmomentmessung.

5. Spitzen-Drehmoment wieder abrufen

Um das zuletzt gemessene Spitzen-Drehmoment wieder anzuzeigen, die Taste **HINTERGRUNDBELEUCHTUNG**  für ca. 3 Sekunden gedrückt halten. Anschließend blinkt das Spitzen-Drehmoment für 10 Sekunden.

### **Winkel (ANGLE)-Modus**

*Hinweis: Kein Drehmoment während der Nullstellung von Drehmoment und Winkel aufbringen.*

*Andernfalls kommt es zu einem falschen Drehmoment-Nullpunktversatz und der Schlüssel zeigt abschließend einen Winkel an. Falls dies auftritt, den Schlüssel wieder auf null stellen, indem Sie kurz die Taste **EIN/AUS**  drücken, während sich der Schlüssel auf einer stabilen Oberfläche ohne Aufbringen eines Drehmoments befindet.*

1. Winkelnullstellung

Wenn „ANGLE ZERO REQ“ angezeigt wird, 2 Sekunden warten, bis die automatische Winkelnullstellung erfolgt ist, bevor der Drehmomentschlüssel angewendet wird.





2. Sollwert einstellen.

Den ANGLE-Sollwert mithilfe der Tasten **AUF** /**AB**  wählen.

3. Drehmoment aufbringen und Schlüssel drehen.

Den Griff in der Mitte packen (NICHT an der Batterie-Abschlusskappe ziehen), das Befestigungselement langsam anziehen und den Schlüssel mit mäßiger, aber gleichbleibender Geschwindigkeit drehen, bis die Fortschrittsanzeige grün leuchtet, ½ Sekunde lang ein akustisches Signal ertönt und der Griff vibriert.

4. Keine weitere Kraft aufbringen.

Spitzendrehmoment (TORQUE) und Spitzenwinkel (ANGLE) blinken nun für 10 Sekunden auf dem LCD-Display. Durch Drücken der Taste **HINTERGRUNDBELEUCHTUNG** , während der Spitzenwinkel blinkt, bleibt die Anzeige bestehen, bis die Taste losgelassen wird. Durch kurzes Drücken der Taste **AUF** /**AB** , **EINGABE**  oder **EINHEITEN**  wird sofort wieder die Soll-Winkel-Anzeige (ANGLE) angezeigt. Durch erneutes Festziehen (Ratschen),

bevor die Sollwertanzeige erscheint, wird der Winkelwert beim Drehen des Schlüssels aufsummiert.

#### 5. Spitzenwinkel wieder abrufen

Um den zuletzt gemessenen Spitzenwinkel wieder anzuzeigen, die Taste **HINTERGRUNDBELEUCHTUNG**  für ca. 3 Sekunden gedrückt halten. Spitzen-Drehmoment (TORQUE) und Spitzen-Drehwinkel (ANGLE) werden abwechselnd für 10 Sekunden angezeigt.

### Anwendungszähler

Der Anwendungszähler des TechAngle<sup>®</sup> dient zur Anzeige, wie oft der Schlüssel das Soll-Drehmoment im Drehmoment-Modus bzw. den Soll-Drehwinkel im Winkel-Modus erreicht hat.

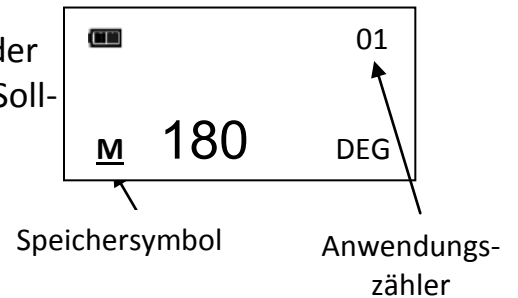





### Drehmoment- und Winkel-Modus Zähler

1. Der numerische Zähler oben rechts neben der Soll-Drehmoment- oder Soll-Winkel-Anzeige erhöht sich jedes Mal, wenn der Schlüssel den Sollwert des Drehmoments bzw. Drehwinkels erreicht hat.
2. Durch Umschalten zwischen Drehmoment-Modus und Winkel-Modus mittels der Taste **EINGABE**  oder durch Änderung des Sollwerts wird der numerische Zähler auf 00 zurückgesetzt. Durch Nullstellung, Aufrufen/Verlassen des Menüs oder Ausschalten wird der Zähler NICHT ZURÜCKGESETZT.
3. Das Speichersymbol erscheint, wenn mindestens ein Drehmoment- oder Drehwinkelwert gespeichert ist.

### Hauptmenü

Das Hauptmenü zeigt die Betriebsdaten des Schlüssels an.

1. In der Soll-Drehmoment- oder Soll-Drehwinkel-Anzeige die Taste **EINGABE**  für 3 Sekunden gedrückt halten.
2. Die gewünschte Menüoption mit den Tasten **AUF** /**AB**  wählen und anschließend die Taste **EINGABE**  drücken.





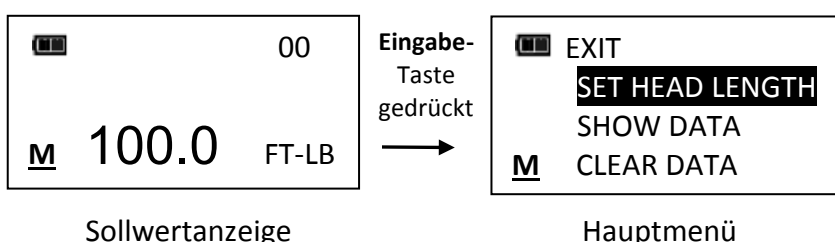





Menüoptionen:

- EXIT – Beendet das Hauptmenü und kehrt zur Sollanzeige zurück.
  - SET HEAD LENGTH – Zur Eingabe der Schlüsselkopflänge.
  - SHOW DATA – Zeigt die gespeicherten Drehmoment- und Drehwinkelwerte an.
  - CLEAR DATA – Löscht die gespeicherten Drehmoment- und Drehwinkelwerte.
  - COUNT CYCLE – Zeigt den Anwendungszähler für Drehmoment/Drehwinkel an.
  - SETTINGS – Zeigt das Menü für erweiterte Einstellungen an (siehe Abschnitt „Erweiterte Einstellungen“).
  - CONFIGURE – Zeigt das Menü für erweiterte Konfiguration an (siehe Abschnitt „Erweiterte Konfiguration“).
3. Um das Hauptmenü zu verlassen und zur Sollwert-Anzeige zurückzukehren, die Taste **EINGABE**  drücken, während die Menüoption **EXIT** angewählt ist.



## Einstellen der Kopflänge

*Hinweis: Wird ein Adapter oder eine Verlängerung am Drehmomentschlüssel verwendet, kann die Länge des Adapters bzw. der Verlängerung eingegeben werden, um die unterschiedliche Kopflänge als bei der Kalibrierung des Schlüssels zu korrigieren, ohne dass eine Neukalibrierung erforderlich ist.*

1. Zur Eingabe einer Kopflänge in der Soll-Drehmoment- oder Soll-Drehwinkel-Anzeige die Taste **EINGABE**  für 3 Sekunden gedrückt halten.
2. Die Menüoption **SET HEAD LENGTH** wählen und kurz die Taste **EINGABE**  drücken.
3. Es erscheint die Anzeige zur Eingabe der Kopflänge. Die Standardkopplänge ist die Kopplänge bei der Kalibrierung. Die angezeigte Kopplänge mit den Tasten **AUF**  / **AB**  erhöhen oder verringern. Durch Gedrückthalten der Tasten **AUF**  / **AB**  ändert sich der Wert zunehmend schneller. Durch gleichzeitiges Drücken der Tasten **AUF**  und **AB**  wird die Kopplänge auf null zurückgestellt.
4. Die Standard-Längeneinheit ist Zoll. Durch Drücken der Taste **EINHEITEN**  wird sie in Millimeter geändert.
5. Durch Drücken der Taste **EINGABE**  nach dem Einstellen der Kopplänge erscheint wieder das Hauptmenü. Wenn die Länge vom Standardwert geändert wurde, erscheint die Meldung „OFFSET IN USE“ in der Sollwertanzeige.

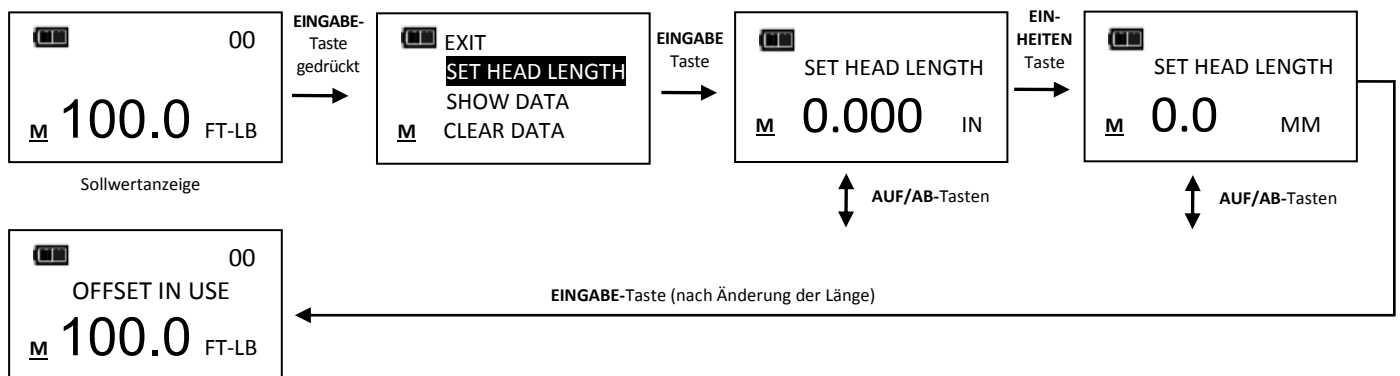

*Hinweis: Die einzugebende Kopplänge ist die Versatzlänge (Offset) gemessen von der Mitte des Antriebsteils bis zur Mitte des Befestigungselements.*

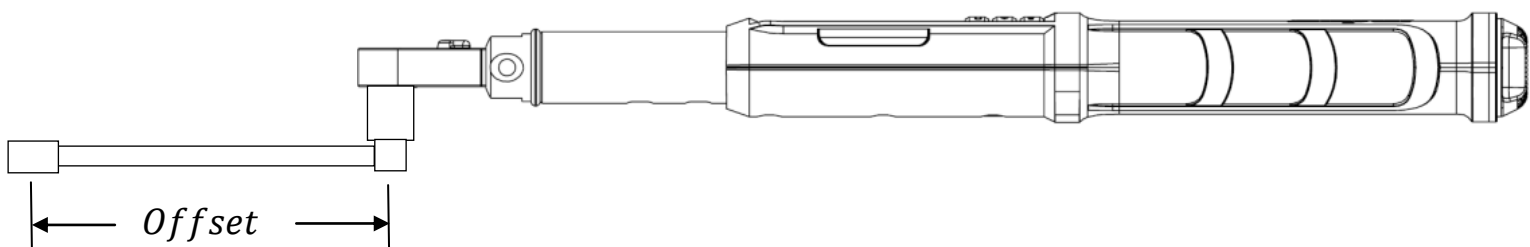

## Verwendung von negativem Versatz

*Hinweis: Ein negativer Versatzwert wird bei Verwendung in umgekehrter Richtung eingegeben.*

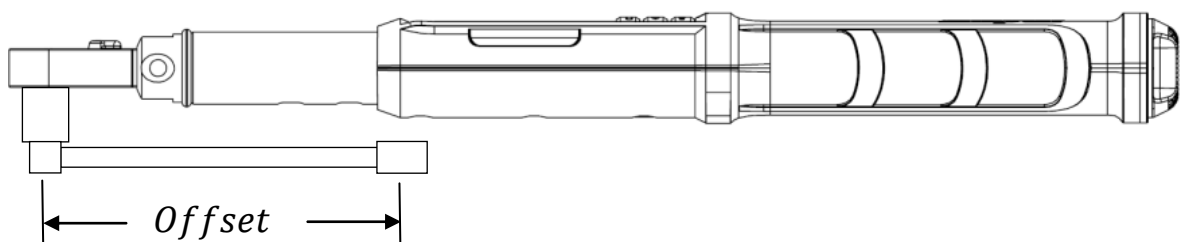

Ist die Versatzlänge negativ, wird der maximale Sollwert für das Befestigungselement durch folgende Formeln begrenzt:

240 in-lb Schlüssel:  
 Maximales Soll-Drehmoment =  
 Versatz \* 24 + 240

Versatz (Offset)	Max. Sollwert
-1"	216 in-lb
-2"	192 in-lb
-3"	168 in-lb
-4"	144 in-lb

100 ft-lb Schlüssel:  
 Maximales Soll-Drehmoment =  
 Versatz \* 8 + 100

Versatz (Offset)	Max. Sollwert
-1"	92 ft-lb
-2"	84 ft-lb
-3"	76 ft-lb
-4"	68 ft-lb

250 ft-lb Schlüssel:  
 Maximales Soll-Drehmoment =  
 Versatz \* 12 + 250

Versatz (Offset)	Max. Sollwert
-1"	238 ft-lb
-2"	226 ft-lb
-3"	214 ft-lb
-4"	202 ft-lb

*Hinweis: Wird bei Verwendung eines negativen Versatzes ein größeres Soll-Drehmoment als die obigen Maximalwerte eingegeben, kann ein Überdrehmoment-Fehler vor dem Erreichen des Soll-Drehmoments des Befestigungselements auftreten und der Schlüssel ggf. beschädigt werden.*

### Gespeicherte Drehmoment- und Drehwinkeldaten anzeigen



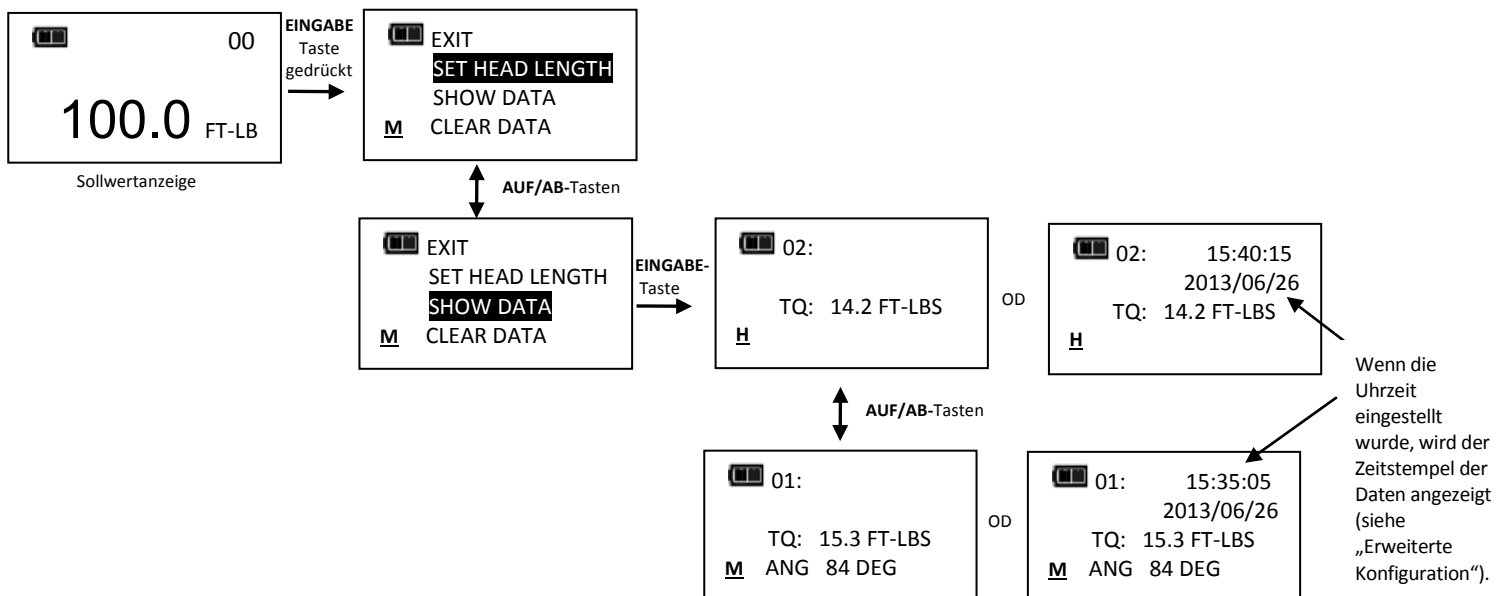

Wenn das aufgebrauchte Drehmoment den Sollwert erreicht hat, wird der Drehmomentwert im Speicher abgelegt. Wenn der aufgebrauchte Drehwinkel den Sollwert erreicht hat, werden der Drehmomentwert und Winkelwert im Speicher abgelegt. Wenn Daten im nicht-flüchtigen Speicher abgelegt sind, erscheint ein Speichersymbol.

- Zur Anzeige der gespeicherten Drehmoment- und Winkelwerte in der Soll-Drehmoment- oder Soll-Drehwinkel-Anzeige die Taste **EINGABE** für 3 Sekunden gedrückt halten.
- Mit den Tasten **AUF** / **AB** die Menüoption **SHOW DATA** wählen und anschließend die Taste **EINGABE** drücken, um die Datenanzeige aufzurufen.
- In der Datenanzeige die einzelnen Datenangaben mit den Tasten **AUF** / **AB** anwählen.  
 Beispiel: 02 = Datenlistenzähler anzeigen: TQ = Spitzendrehmoment  
 01 = Datenlistenzähler anzeigen: TQ = Spitzendrehmoment: ANG = Spitzenwinkel
- Durch Drücken der Taste **EINGABE** während der Datenanzeige erscheint wieder das Hauptmenü.



*Hinweis: Maximal 50 Datensätze können gespeichert werden. Ist der Speicher voll, wird dies durch ein Symbol angezeigt. Neue Daten ersetzen die ältesten Daten, bis der Speicher gelöscht wird.*





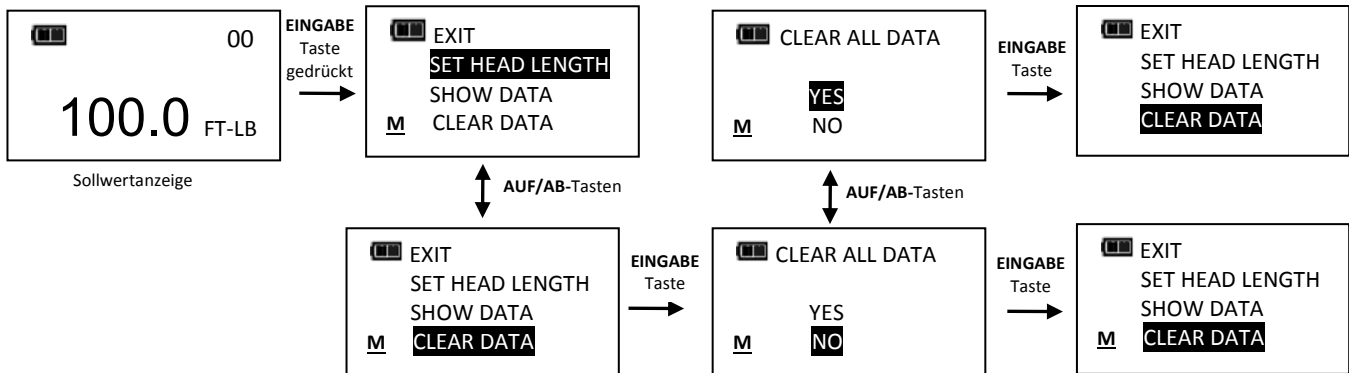

## Gespeicherte Drehmoment- und Drehwinkeldaten löschen

1. In der Soll-Drehmoment- oder Soll-Drehwinkel-Anzeige die Taste **EINGABE**  für 3 Sekunden drücken.
2. Mit den Tasten **AUF** /**AB**  die Menüoption **CLEAR DATA** wählen und anschließend die Taste **EINGABE**  drücken, um die Anzeige CLEAR ALL DATA aufzurufen.
3. In der Anzeige CLEAR ALL DATA die Menüoption **YES** wählen, um alle gespeicherten Daten zu löschen, oder **NO** wählen, um keine Daten zu löschen.
4. Anschließend die Taste **EINGABE**  drücken.



## Anwendungszähler anzeigen und löschen

Jedes Mal, wenn der Sollwert des Drehmoments oder Drehwinkels erreicht wird, erhöht sich der Anwendungszähler. Der Maximalwert ist 999999.

1. In der Soll-Drehmoment- oder Soll-Drehwinkel-Anzeige die Taste **EINGABE**  für 3 Sekunden gedrückt halten.
2. Mit den Tasten **AUF** /**AB**  die Menüoption **CYCLE COUNT** wählen.
3. Die Taste **EINGABE**  wählen, um die Anzeige CYCLES aufzurufen.
4. Um die Anzeige CYCLE COUNT ohne Löschen des Zahlenwerts zu verlassen, die Taste **EINGABE**  drücken, während die Menüoption **EXIT** gewählt ist.
5. Um den Anwendungszähler auf 0 zurückzusetzen, die Menüoption **CLEAR** wählen und anschließend die Taste **EINGABE**  drücken.
6. Die Menüoption **EXIT** wird nach Löschen des Zählers automatisch gewählt. Die Taste **EINGABE**  drücken, um zum Hauptmenü zurückzukehren.

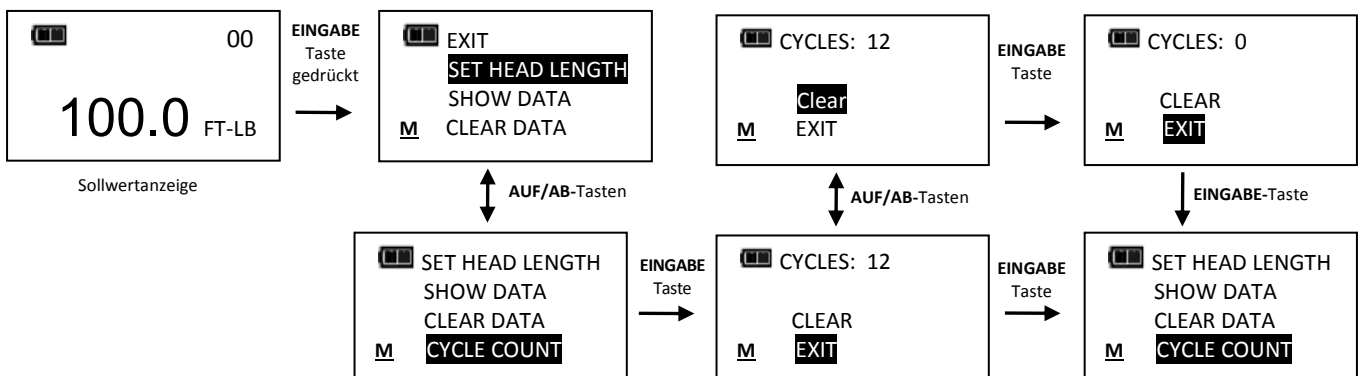

## Voreinstellungen (PSET)

Die PSET-Funktion bietet dem Benutzer die Möglichkeit, 10 Sollvorgaben für das Drehmoment oder den Drehwinkel, jeweils mit Mindestwert (Soll), Höchstwert (Überbereich) und Batch-Zählwert, voreinzustellen. PSET-Voreinstellungen werden im nicht-flüchtigen Speicher abgelegt, sodass sie beim Ausschalten des Geräts erhalten bleiben.

### Eingabe einer Drehmoment-Voreinstellung

1. In der Drehmoment-Anzeige die Maßeinheit wählen.
2. Die Taste **EINHEITEN** **U** für 3 Sekunden gedrückt halten.

- Die Bestätigungsanzeige ADD PRESET wird angezeigt. Mit den Tasten **AUF** ▲ / **AB** ▼ die Menüoption **YES** wählen und anschließend die Taste **EINGABE** ↵ drücken. Die Menüoption **NO** führt zum Hauptmenü zurück, ohne eine Sollvorgabe einzugeben.
- MINIMUM TORQUE ist der Sollwert, bei dem die grüne Fortschrittanzeige leuchtet, das akustische Signal ertönt und der Vibrator eingeschaltet wird. Anfänglich wird hier der Wert von der Soll-Drehmoment-Anzeige angezeigt. Durch Drücken der Tasten **AUF** ▲ / **AB** ▼ kann hier ein beliebiger Wert innerhalb des Drehmomentbereichs des Schlüssels eingestellt werden. Nachdem der gewünschte Soll-Drehmomentwert eingestellt wurde, die Taste **EINGABE** ↵ drücken.
- Als Nächstes erscheint die Anzeige MAXIMUM TORQUE. MAXIMUM TORQUE ist der Drehmomentwert, bei dem die rote Fortschrittanzeige leuchtet. Der anfängliche Wert ist MINIMUM TORQUE + 4 %. Durch Drücken der Tasten **AUF** ▲ / **AB** ▼ kann der maximale Drehmomentwert auf MINIMUM TORQUE + 10 % über dem Maximalbereich des Schlüssels eingestellt werden. Nachdem der gewünschte Wert eingestellt wurde, die Taste **EINGABE** ↵ drücken.
- Als Nächstes erscheint die Anzeige BATCH COUNT. Der Standardwert ist null. Der Batch-Zähler reicht von 0 bis 99. Den angezeigten Batch-Zähler mit den Tasten **AUF** ▲ / **AB** ▼ erhöhen oder verringern. Wird ein Zähler von null eingegeben, erhöht sich der Modus-Zähler jedes Mal, wenn das Soll-Drehmoment erreicht wird. Bei Eingabe eines von null verschiedenen Batch-Zählerstands wird der Modus-Zähler verringert; bei Erreichen von null setzt sich der Zähler auf den Batch-Zählerstand zurück. Nachdem der gewünschte Wert eingestellt wurde, die Taste **EINGABE** ↵ drücken.
- Die PSET-Sollanzeige wird mit der nächsten verfügbaren PSET-Nummer von 01 bis 10 dargestellt.
- Um zusätzliche Drehmoment-Sollvorgaben einzugeben, wiederholt die Taste **EINGABE** ↵ drücken, bis die Soll-Drehmoment-Anzeige erscheint, und die obigen Schritte wiederholen.

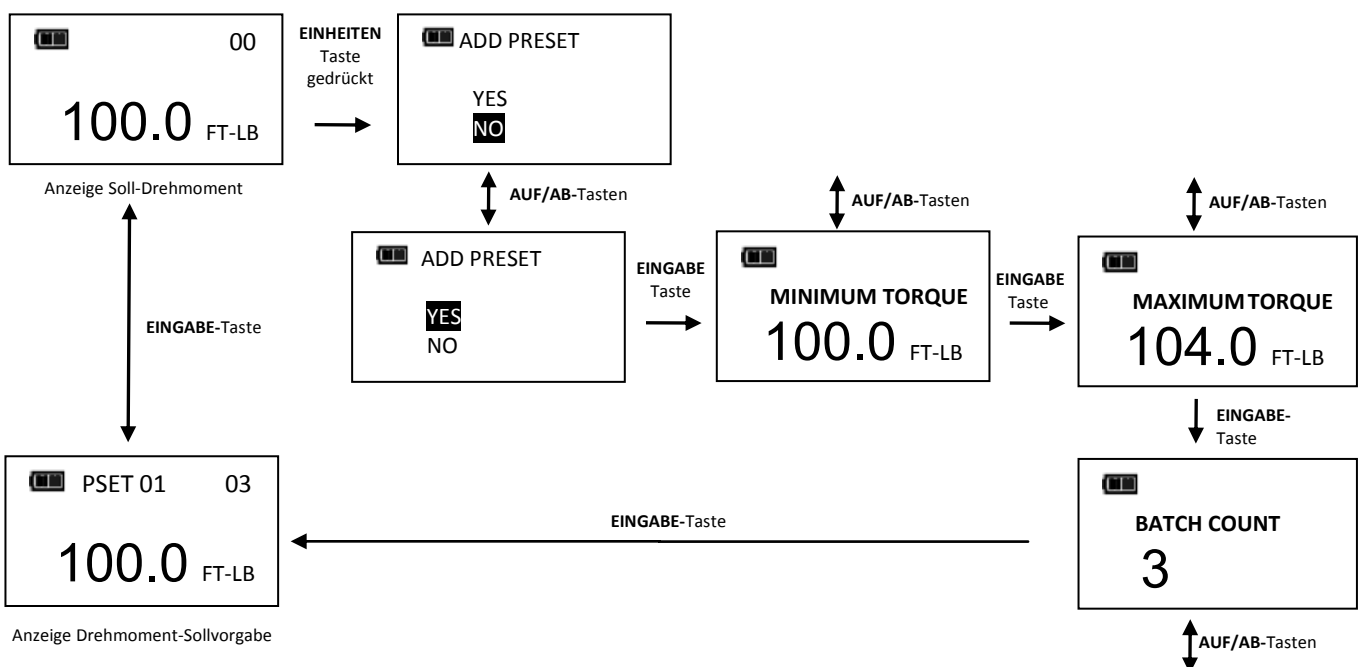

*Hinweis: Um einen gespeicherten PSET- oder manuellen Soll-Drehmoment- oder Soll-Drehwinkel-Modus auszuwählen, wiederholt die Taste **EINGABE** ↵ drücken, bis der gewünschte PSET- oder manuelle Modus angezeigt wird.*

### **Eingabe einer Drehwinkel-Voreinstellung**

- In der Soll-Drehwinkel-Anzeige die Taste **EINHEITEN** **U** für 3 Sekunden gedrückt halten.
- Die Bestätigungsanzeige ADD PRESET wird angezeigt. Mit den Tasten **AUF** ▲ / **AB** ▼ die Menüoption **YES** wählen und anschließend die Taste **EINGABE** ↵ drücken. Die Menüoption **NO** führt zum Hauptmenü zurück, ohne eine Voreinstellung einzugeben.
- Als Nächstes erscheint die Anzeige MINIMUM ANGLE. MINIMUM ANGLE ist der Sollwert, bei dem die grüne Fortschrittanzeige leuchtet, das akustische Signal ertönt und der Vibrator eingeschaltet wird. Anfänglich wird hier der Wert von der Soll-Drehwinkel-Anzeige angezeigt. Der Minimalwinkel kann durch Drücken der Tasten **AUF** ▲ / **AB** ▼ im Bereich von 0 bis 360° eingestellt werden. Nachdem der gewünschte Soll-Drehwinkelwert eingestellt wurde, die Taste **EINGABE** ↵ drücken.

- Als Nächstes erscheint die Anzeige MAXIMUM ANGLE. MAXIMUM ANGLE ist der Drehwinkelwert, bei dem die rote Fortschrittanzeige leuchtet. Der anfängliche Wert ist MINIMUM ANGLE + 4 %. Durch Drücken der Tasten **AUF** ▲ / **AB** ▼ kann hier ein beliebiger Wert über dem Minimalwinkel eingestellt werden. Nachdem der gewünschte Wert eingestellt wurde, die Taste **EINGABE** ⏏ drücken.
- Als Nächstes erscheint die Anzeige BATCH COUNT. Der Standardwert ist null. Der Batch-Zähler reicht von 0 bis 99. Den angezeigten Batch-Zähler mit den Tasten **AUF** ▲ / **AB** ▼ erhöhen oder verringern. Wird ein Zähler von null eingegeben, erhöht sich der Modus-Zähler jedes Mal, wenn der Soll-Drehwinkel erreicht wird. Bei Eingabe eines von null verschiedenen Batch-Zählerstands wird der Modus-Zähler verringert; bei Erreichen von null setzt sich der Zähler auf den Batch-Zählerstand zurück. Nachdem der gewünschte Wert eingestellt wurde, die Taste **EINGABE** ⏏ drücken.
- Die PSET-Sollanzeige wird mit der nächsten verfügbaren PSET-Nummer von 01 bis 10 dargestellt.
- Um zusätzliche Drehwinkel-Sollvorgaben einzugeben, wiederholt die Taste **EINGABE** ⏏ drücken, bis die Soll-Drehwinkel-Anzeige erscheint, und die obigen Schritte wiederholen.

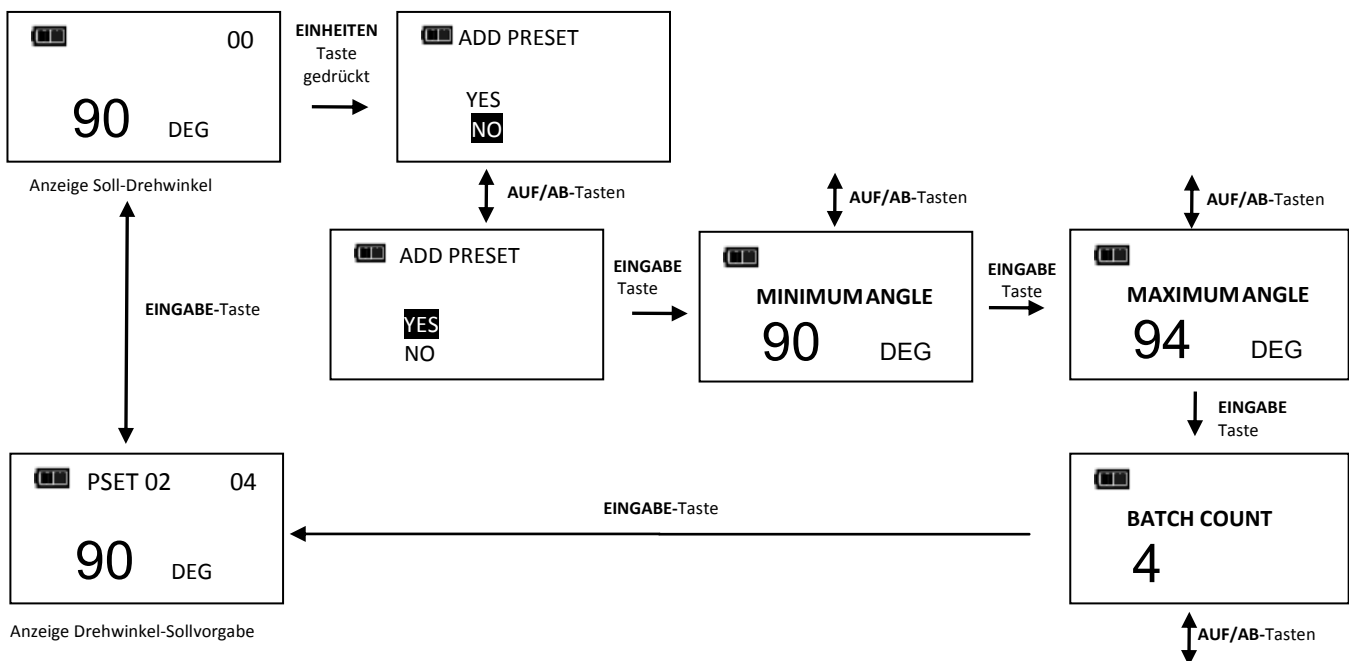

*Hinweis: Um einen gespeicherten PSET- oder manuellen Soll-Drehmoment- oder Soll-Drehwinkel-Modus auszuwählen, wiederholt die Taste **EINGABE** ⏏ drücken, bis der gewünschte PSET- oder manuelle Modus angezeigt wird.*

### Voreinstellung ändern

Die PSET-Funktion gibt dem Benutzer die Möglichkeit, gespeicherte PSET-Voreinstellungen im Schlüssel zu ändern.

- In der zu ändernden Voreinstellungs-Anzeige die Taste **EINHEITEN** **U** für 3 Sekunden gedrückt halten.
- Die Anzeige CHANGE PRESET erscheint.
- Mit den Tasten **AUF** ▲ / **AB** ▼ die Menüoption **EDIT** wählen und anschließend die Taste **EINGABE** ⏏ drücken.
- Die Anzeige MINIMUM TORQUE bzw. ANGLE erscheint. Der Wert kann durch Drücken der Tasten **AUF** ▲ / **AB** ▼ geändert werden. Nachdem der gewünschte Soll-Drehmoment- bzw. Soll-Drehwinkelwert eingestellt wurde, die Taste **EINGABE** ⏏ drücken.
- Die Anzeige MAXIMUM TORQUE bzw. ANGLE erscheint. Der Wert kann durch Drücken der Tasten **AUF** ▲ / **AB** ▼ geändert werden. Nachdem der gewünschte Soll-Drehmoment- bzw. Soll-Drehwinkelwert eingestellt wurde, die Taste **EINGABE** ⏏ drücken.
- Als Nächstes erscheint die Anzeige BATCH COUNT. Der Wert kann durch Drücken der Tasten **AUF** ▲ / **AB** ▼ geändert werden. Nachdem der gewünschte Batch-Zählwert eingestellt wurde, die Taste **EINGABE** ⏏ drücken.





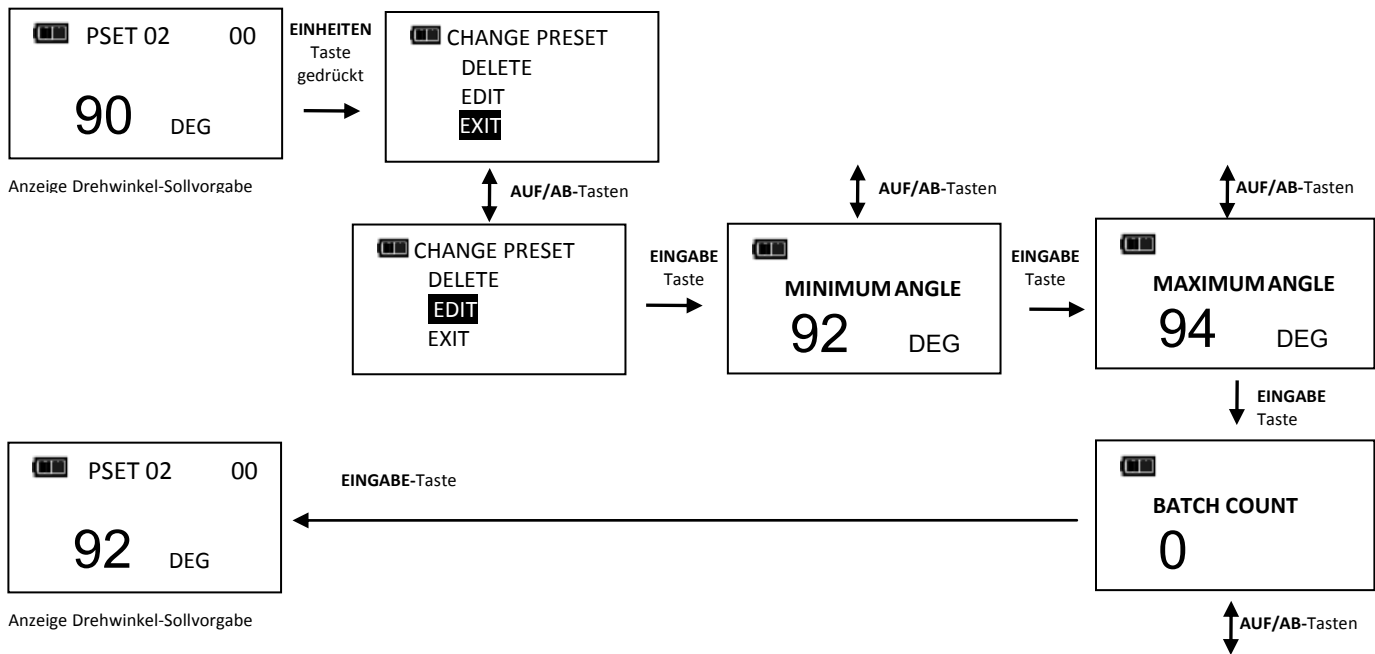

7. Die PSET-Sollanzeige wird mit der gleichen PSET-Nummer dargestellt.





*Hinweis: Durch Drücken der Taste **EINGABE** , während die Menüoption **EXIT** ausgewählt ist, wird das Menü ohne Änderung des PSET-Werts verlassen.*

### Voreinstellung löschen

Die PSET-Funktion ermöglicht dem Benutzer, gespeicherte Voreinstellungen im Schlüssel zu löschen.

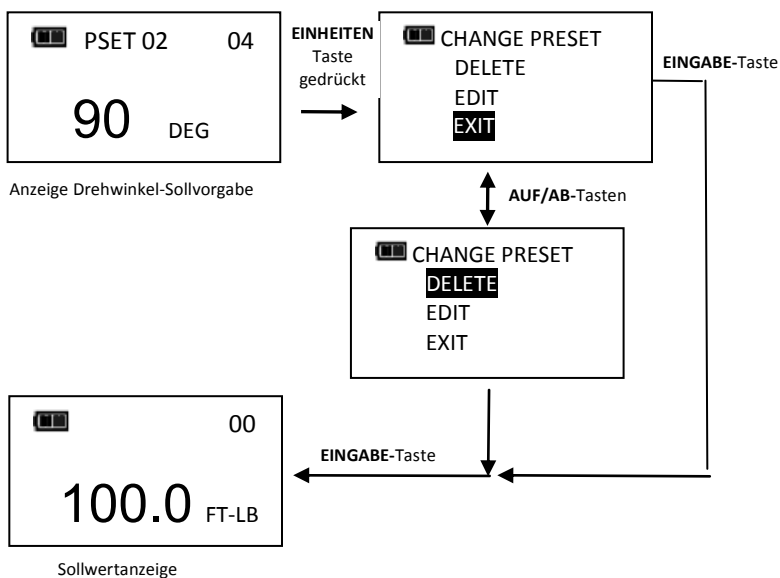
1. In der zu löschenden Voreinstellungs-Anzeige die Taste **EINHEITEN**  für 3 Sekunden gedrückt halten.
2. Die Anzeige CHANGE PRESET erscheint.
3. Mit den Tasten **AUF**  / **AB**  die Menüoption **DELETE** wählen und die Taste **EINGABE**  drücken.
4. Die Sollwertanzeige erscheint, und die gelöschte PSET-Voreinstellung steht darin nicht mehr zur Auswahl.







*Hinweis: Durch Drücken der Taste **EINGABE** , während die Menüoption **EXIT** gewählt ist, wird das Menü ohne Löschen der PSET-Voreinstellung verlassen.*

*Hinweis: Wenn eine PSET-Voreinstellung gelöscht wird, bleiben alle anderen gespeicherten PSET-Voreinstellungen unverändert erhalten. Wenn eine neue PSET-Voreinstellung eingegeben wird, erhält sie die erste verfügbare PSET-Nummer.*



## • Erweiterte Einstellungen

### Aufrufen der erweiterten Einstellungen

Die erweiterten Einstellungen werden über die Menüoption **SETTINGS** im Hauptmenü aufgerufen.

1. In der Soll-Drehmoment- oder Soll-Drehwinkel-Anzeige die Taste **EINGABE**  für 3 Sekunden gedrückt halten.
2. Mit den Tasten **AUF** /**AB**  die Menüoption **SETTINGS** wählen.
3. Die Taste **EINGABE**  drücken, um das Menü „Settings“ anzuzeigen.

Menüoptionen:

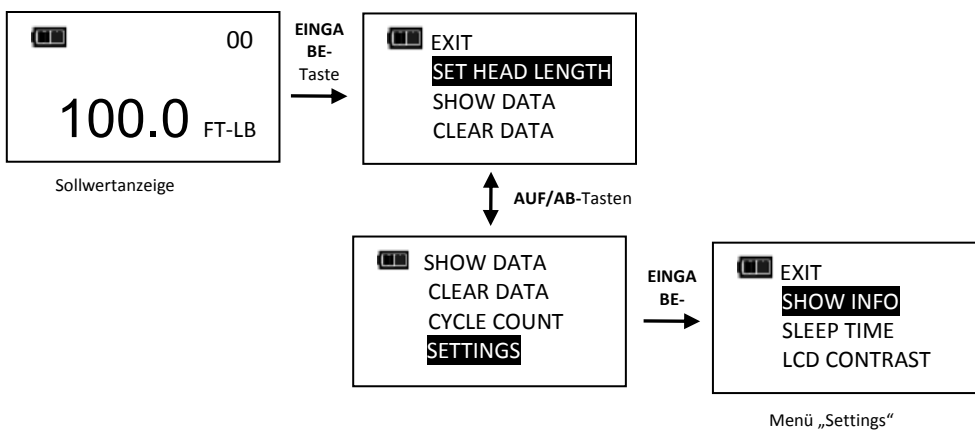

- EXIT – Beendet das Menü „Settings“ und kehrt zur Sollanzeige zurück.
  - SHOW INFO – Zeigt Betriebsdaten des Schlüssels an.
  - SLEEP TIME – Zur Änderung der Abschaltzeit bei Nichtverwendung.
  - LCD CONTRAST – Zur Änderung des Kontrasts des LCD-Displays.
  - KEY BEEP – Zum Ein-/Ausschalten des Tastentons.
  - AUTO BACKLIGHT – Zum Ein-/Ausschalten der automatischen Hintergrundbeleuchtung beim Messen.
  - TOGGLE BACKLIGHT – Zur Anzeige der Umschalttaste für die **HINTERGRUNDBELEUCHTUNG**  und zur Einstellung der Zeitgrenze.
  - VIBRATOR CONFIG – Zum Ein-/Ausschalten des Vibrators bei Erreichen des Sollwerts.
4. Um das Menü „Settings“ zu verlassen und zur Sollwert-Anzeige zurückzukehren, die Taste **EINGABE**  drücken, während die Menüoption **EXIT** angewählt ist.



*Hinweis: Alle vom Benutzer konfigurierbaren Einstellungen werden im nicht-flüchtigen Speicher abgelegt und bleiben auch bei ausgeschaltetem Gerät erhalten.*

### Info anzeigen

Die Menüoption „Show Info“ zeigt die Betriebsdaten des Drehmomentschlüssels an.

1. Im Menü „Settings“ die Taste **EINGABE**  drücken, während die Option **SHOW INFO** gewählt ist.
2. Die Anzeige SHOW INFO erscheint.
3. Mit den Tasten **AUF** /**AB**  kann die Anzeige gescrollt werden.

Betriebsdaten

- CAL: Datum der letzten Kalibrierung des Schlüssels.
  - ISD: Datum der Inbetriebnahme.
  - TCF: Drehmoment-Kalibrierungsfaktor.
  - ACF: Winkel-Kalibrierungsfaktor.
  - VER: Softwareversion.
  - OVR CNT: Der Überdrehmoment-Zähler verfolgt, wie oft ein Überdrehmoment-Ereignis im Schlüssel (Drehmoment > 125 % der Gesamtskala) auftrat.
  - TQZ: Drehmoment-Nullpunktversatz.
  - ANZ: Winkel-Nullpunktversatz.
4. Durch Drücken der Taste **EINGABE**  wird die Anzeige der Betriebsdaten verlassen und zum Menü „Settings“ zurückgekehrt.

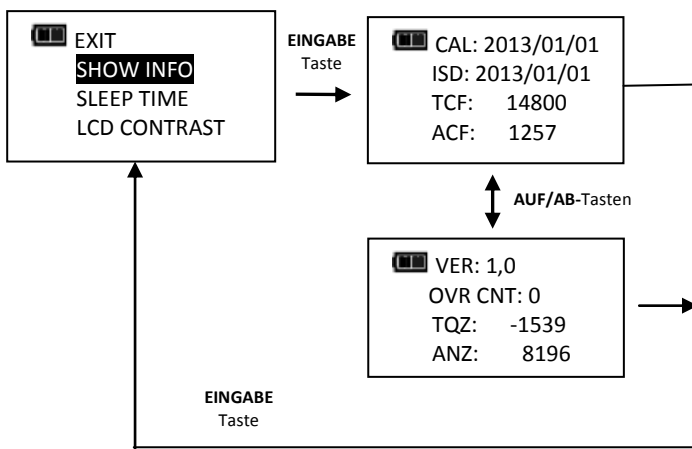

## Einstellung des Sleep-Timers

Diese Funktion ermöglicht dem Benutzer, eine Zeit einzugeben, nach der sich der Schlüssel bei Untätigkeit nach der letzten Anwendung abschaltet.

1. Im Menü „Settings“ mit den Tasten **AUF** ▲ / **AB** ▼ die Option **SLEEP TIME** wählen und anschließend die Taste **EINGABE** ↵ drücken.
2. Die Anzeige SLEEP TIME erscheint.
3. Mit den Tasten **AUF** ▲ / **AB** ▼ das gewünschte Intervall bis zum Abschalten wählen.

Wählbare Intervalle:

- 2 MIN (Werkseinstellung)
- 5 MIN
- 10 MIN
- 30 MIN
- 1 HR
- 2 HR
- 8 HR

4. Die Taste **EINGABE** ↵ drücken, um die Auswahl zu übernehmen und das Menü „Settings“ zu verlassen.

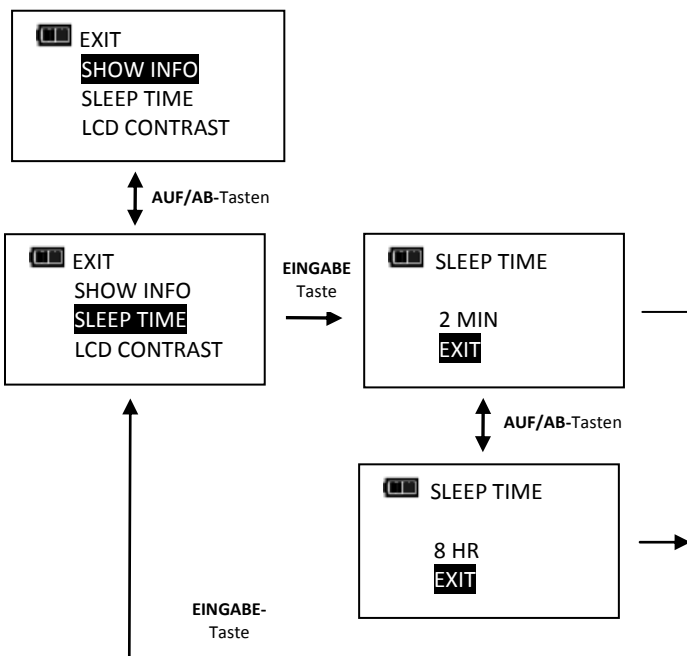

## Einstellung des LCD-Kontrasts

Diese Funktion ermöglicht dem Benutzer, den LCD-Kontrast für eine optimale Anzeige einzustellen.





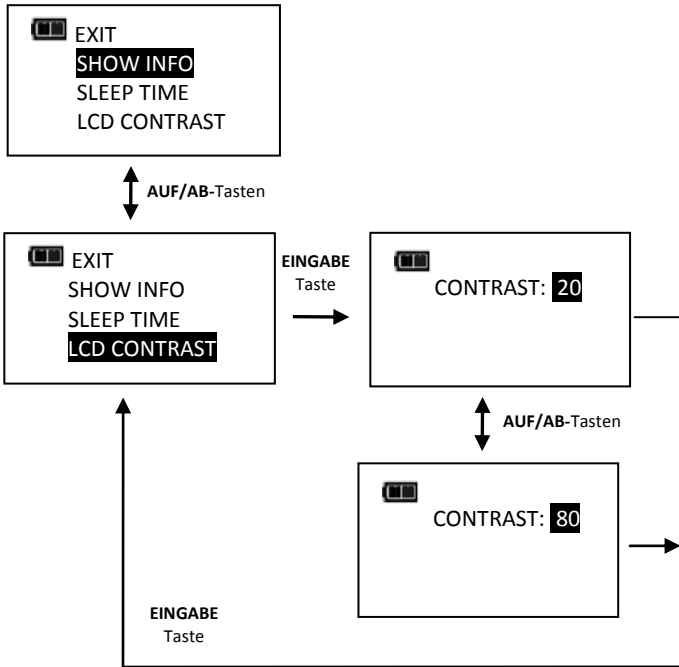

1. Im Menü „Settings“ mit den Tasten **AUF** ▲ / **AB** ▼ die Option **LCD CONTRAST** wählen und anschließend die Taste **EINGABE** ↵ drücken.
2. Die Anzeige CONTRAST erscheint.
3. Mit den Tasten **AUF** ▲ / **AB** ▼ unter Beobachtung der Anzeige den gewünschten Kontrast einstellen. Einstellbereich: 20 bis 80 in Schritten von 5 (Werkseinstellung: 40).

- Die Taste **EINGABE**  drücken, um die Auswahl zu übernehmen und das Menü „Settings“ zu verlassen.



### Einstellung des Tastentons



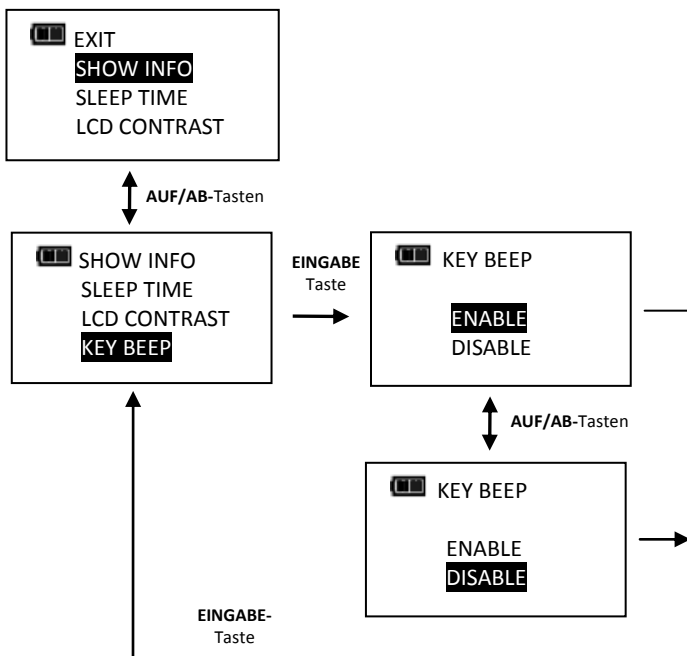

Diese Funktion ermöglicht dem Benutzer, eine akustische Bestätigung beim Drücken einer Taste zu aktivieren oder deaktivieren.

- Im Menü „Settings“ mit den Tasten **AUF** /**AB**  die Option **KEY BEEP** wählen und anschließend die Taste **EINGABE**  drücken.
- Die Anzeige KEY BEEP erscheint.
- Mit den Tasten **AUF** /**AB**  die Option ENABLE (Aktivieren, Werkseinstellung) oder DISABLE (Deaktivieren) wählen.
- Die Taste **EINGABE**  drücken, um die Auswahl zu übernehmen und das Menü „Settings“ zu verlassen.



### Automatische Hintergrundbeleuchtung



Diese Funktion ermöglicht dem Benutzer zu bestimmen, ob bei der Drehmoment- oder Winkelmessung automatisch die Hintergrundbeleuchtung eingeschaltet werden soll.



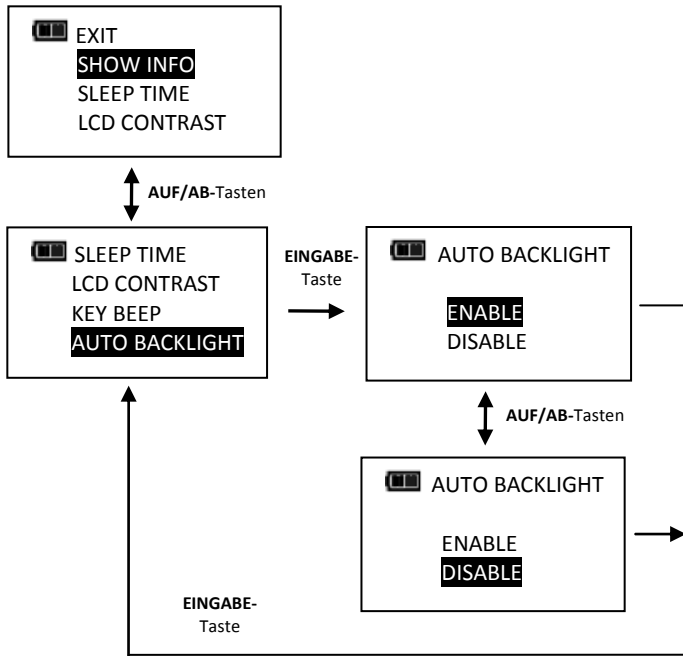



- Im Menü „Settings“ mit den Tasten **AUF** /**AB**  die Option **AUTO BACKLIGHT** wählen und anschließend die Taste **EINGABE**  drücken.
- Die Anzeige AUTO BACKLIGHT erscheint.
- Mit den Tasten **AUF** /**AB**  die Option ENABLE (Aktivieren, Werkseinstellung) oder DISABLE (Deaktivieren) wählen.

4. Die Taste **EINGABE**  drücken, um die Auswahl zu übernehmen und das Menü „Settings“ zu verlassen.



### Schalter Hintergrundbeleuchtung

Diese Funktion ermöglicht dem Benutzer, den Schalter für Hintergrundbeleuchtung zu aktivieren oder deaktivieren. Wird der Schaltmodus deaktiviert, wird die Hintergrundbeleuchtung durch die Taste **HINTERGRUNDBELEUCHTUNG**  eingeschaltet und fünf Sekunden nach dem letzten Tastendruck automatisch ausgeschaltet. Ist der Schaltmodus aktiviert, wird die Hintergrundbeleuchtung durch Betätigung der Taste **HINTERGRUNDBELEUCHTUNG**  eingeschaltet und erst durch erneutes Drücken der Taste **HINTERGRUNDBELEUCHTUNG**  wieder ausgeschaltet.

1. Im Menü „Settings“ mit den Tasten **AUF**  / **AB**  die Option **TOGGLE BACKLIGHT** wählen und anschließend die Taste **EINGABE**  drücken.
2. Die Anzeige TOGGLE BACKLIGHT erscheint.
3. Mit den Tasten **AUF**  / **AB**  die Option ENABLE (Aktivieren) oder DISABLE (Deaktivieren, Werkseinstellung) wählen.
4. Die Taste **EINGABE**  drücken, um die Auswahl zu übernehmen und das Menü „Settings“ zu verlassen.

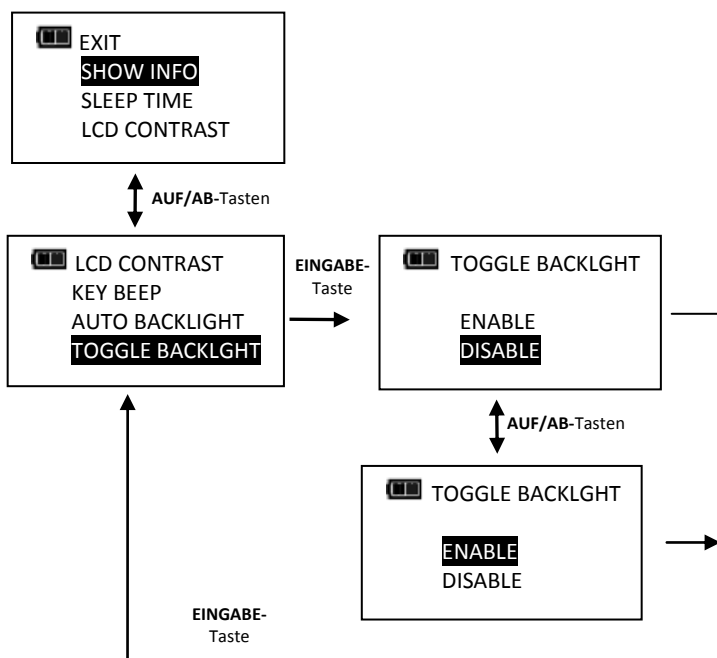

*Hinweis: Die Hintergrundbeleuchtung erlischt durch Ausschalten des Drehmomentschlüssels über die Taste **EIN/AUS**  oder durch die Sleep-Funktion.*

*Hinweis: Wenn die Schaltfunktion der Hintergrundbeleuchtung aktiviert und die Hintergrundbeleuchtung eingeschaltet ist, bleibt die Hintergrundbeleuchtung während und nach dem Aufbringen des Drehmoments erhalten.*

## Vibrator-Konfiguration

Diese Funktion ermöglicht dem Benutzer zu bestimmen, ob der Vibrator beim Erreichen des Sollwerts aktiviert oder deaktiviert werden soll, um z. B. die Batterien zu schonen.

1. Im Menü „Settings“ mit den Tasten **AUF** ▲ / **AB** ▼ die Option **VIBRATOR CONFIG** wählen und anschließend die Taste **EINGABE** ⏏ drücken.
2. Die Anzeige VIBRATOR CONFIG erscheint.
3. Mit den Tasten **AUF** ▲ / **AB** ▼ die Option ON (Ein) oder OFF (Aus) wählen.
4. Die Taste **EINGABE** ⏏ drücken, um die Auswahl zu übernehmen und das Menü „Settings“ zu verlassen.

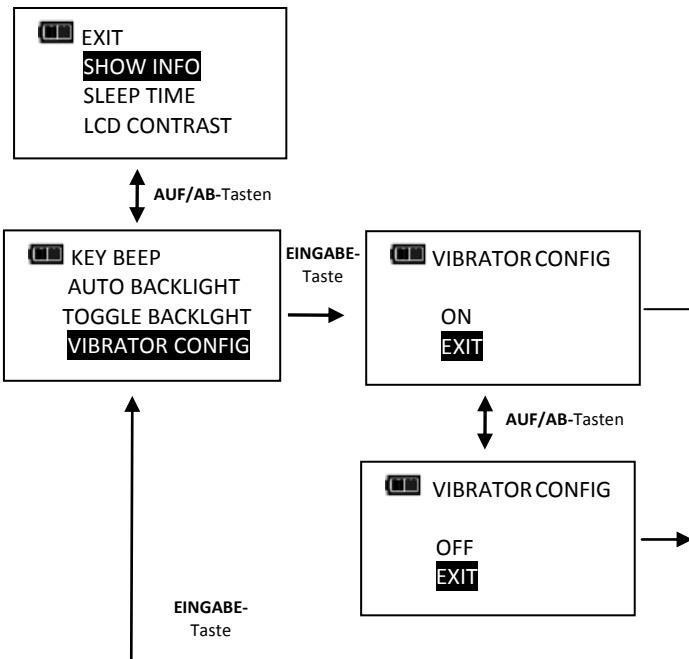

## • Erweiterte Konfiguration

### Aufrufen der erweiterten Konfiguration

Die erweiterte Konfiguration wird über die Menüoption **CONFIGURE** im Hauptmenü aufgerufen.

1. In der Soll-Drehmoment- oder Soll-Drehwinkel-Anzeige die Taste **EINGABE** ⏏ für 3 Sekunden gedrückt halten.
2. Mit den Tasten **AUF** ▲ / **AB** ▼ die Menüoption **CONFIGURE** wählen.
3. Die Taste **EINGABE** ⏏ drücken, um das Menü „Configure“ anzuzeigen.

Menüoptionen:

- EXIT – Beendet das Menü „Configure“ und kehrt zur Sollanzeige zurück.
  - MODE SETUP – Zeigt das Einstellmenü für den Schlüsselmodus an.
  - CALIBRATION – Zeigt das Kalibrieremenü (passwortgeschützt) des Schlüssels an.
  - SET DATE/TIME – Zur Einstellung von Datum und Uhrzeit.
  - SET CAL INTRVAL – Zur Anzeige des Kalibrierintervalls (erfordert Einstellung von Datum und Uhrzeit).
4. Um das Menü „Configure“ zu verlassen und zur Sollwert-Anzeige zurückzukehren, die Taste **EINGABE** ⏏ drücken, während die Menüoption **EXIT** angewählt ist.

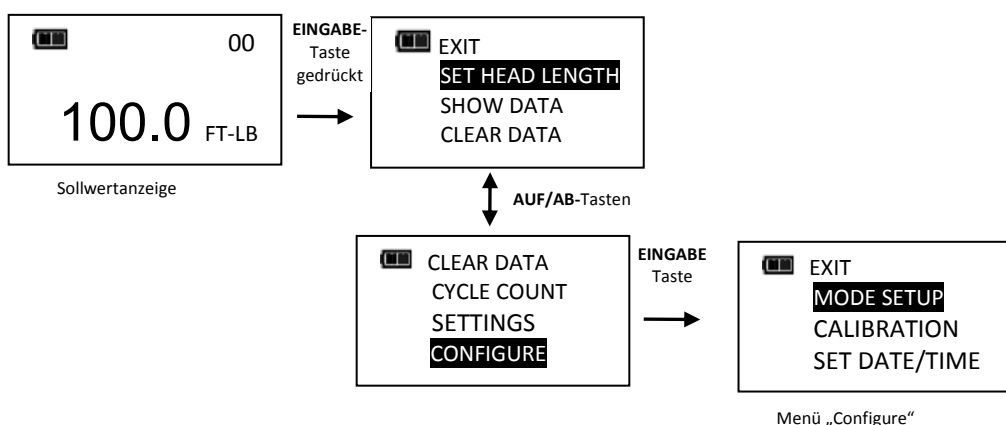

*Hinweis: Alle vom Benutzer konfigurierbaren Einstellungen werden im nicht-flüchtigen Speicher abgelegt und bleiben auch bei ausgeschaltetem Gerät erhalten.*

## Modus-Einstellung

Das Modus-Einstellmenü ermöglicht dem Benutzer, den Winkel-Modus und DANN (THEN) den Drehmoment-Modus zu aktivieren/deaktivieren.

1. Im Menü „Configure“ die Taste **EINGABE** drücken, während die Option **MODE SETUP** gewählt ist.
2. Das Menü „Mode Setup“ wird angezeigt.  
Menüoptionen:
  - EXIT – Beendet das Modus-Einstellmenü und kehrt zum Konfigurationsmenü zurück.
  - THEN DISABLED – Zur Aktivierung/Deaktivierung des nachfolgenden DANN-Winkel-Modus.
3. Mit den Tasten **AUF** / **AB** die gewünschten Menüoptionen wählen.
4. Die Taste **EINGABE** drücken, während die Menüoption **EXIT** gewählt ist, um zum Menü „Configure“ zurückzukehren.

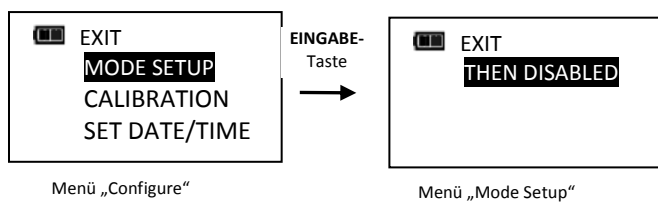

## Drehmoment-DANN-Winkel-Modus aktivieren/deaktivieren

Diese Funktion ermöglicht dem Benutzer, den Winkel-Modus im Anschluss an das Drehmoment zu aktivieren oder deaktivieren.

1. Im Menü „Mode Setup“ mit den Tasten **AUF** / **AB** die Option **THEN DISABLED** (Werkseinstellung) wählen und anschließend die Taste **EINGABE** drücken.
2. Die Anzeige TQ THEN ANGLE (Drehmoment-DANN-Winkel) erscheint.
3. Mit den Tasten **AUF** / **AB** die Option ENABLE (Aktivieren) oder DISABLE (Deaktivieren) wählen.
4. Die Taste **EINGABE** drücken, um die Auswahl zu übernehmen und das Menü „Mode Setup“ zu verlassen.

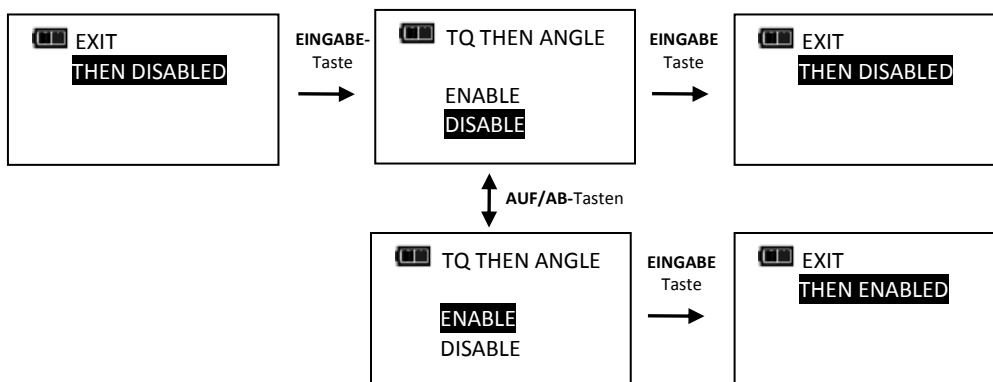

*Hinweis: Die Menüoption zeigt die aktuelle Konfiguration (ENABLED = aktiviert oder DISABLED = deaktiviert) an.*

## Drehmoment-DANN-Winkel-Modus

Der Drehmoment-DANN-Winkel-Modus wird eingerichtet, indem zuerst ein Soll-Drehmoment und eine Maßeinheit und dann ein Soll-Winkel eingestellt wird, bevor der Drehmoment-DANN-Winkel-Modus gewählt wird. Im Drehmoment-DANN-Winkel Modus schaltet der Schlüssel automatisch in den Winkel-Modus zur Winkelmessung, wenn das aufgebraachte Drehmoment den Sollwert erreicht. Die Fortschrittanzeigeleuchten zeigen das bereits aufgebraachte Drehmoment bei der Drehmomentmessung und den Winkel bei der Winkelmessung an.

1. In der Soll-Drehmoment-Anzeige mit den Tasten **AUF ▲** / **AB ▼** das Soll-Drehmoment und mit der Taste **EINHEITEN U** die Maßeinheit der Drehmomentmessung wählen und anschließend die Taste **EINGABE ↵** drücken.
2. Die Soll-Winkel-Anzeige erscheint. Mit den Tasten **AUF ▲** / **AB ▼** den gewünschten Soll-Winkel einstellen und anschließend die Taste **EINGABE ↵** drücken.
3. Die Anzeige „Torque THEN Angle“ erscheint.
4. Befestigungselement bis zum Soll-Drehmoment anziehen und anschließend den Schlüssel bis zum Soll-Winkel drehen.



*Hinweis: In der Anzeige „Torque THEN Angle“ kann die Maßeinheit des Drehmoments mit der Taste **EINHEITEN U** gewählt werden.*

*Hinweis: Drehmoment-DANN-Winkel-Sollvorgaben werden durch Gedrückthalten der Taste Einheiten eingegeben, während man sich in der Anzeige „Torque THEN Angle“ befindet. Zur Parametereingabe siehe „Eingabe einer Drehmoment-Sollvorgabe“ und „Eingabe einer Winkel-Sollvorgabe“ im Abschnitt „Grundfunktionen“.*

*Hinweis: Der Drehmoment-Zyklus wird nur im Speicher aufgezeichnet, wenn sowohl Drehmoment als auch Drehwinkel den Sollwert erreichen.*

*Hinweis: Die roten und gelben Fortschrittanzeigen leuchten, wenn das Drehmoment 110 % der Gesamtskala des Schlüssels bzw. der Winkel im manuellen Modus den Sollwert + 4 % überschreitet.*

*Hinweis: Die roten und gelben Fortschrittanzeigen leuchten, wenn das Drehmoment das maximale Drehmoment bzw. der Winkel den maximalen Winkel im Vorgabe-Modus überschreitet.*

## **Kalibrierung**

Das Kalibrier-Menü ist durch ein Passwort geschützt. Kontaktieren Sie Ihr lokales Snap-on Reparatur-Center bezüglich des Kalibrier-Menüs.

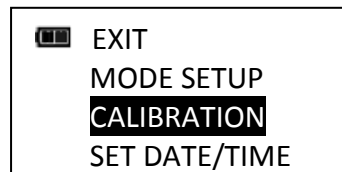

## **Datum und Uhrzeit einstellen**

Die Datum/Uhrzeit-Funktion ermöglicht dem Benutzer, das Datum und die Uhrzeit für das Zeitstempeln von Datensätzen, Aufzeichnen des letzten Kalibrierdatums und Benachrichtigung des Benutzers bei Ablauf des Kalibrierungsintervalls einzustellen.

*Hinweis: Bei der erstmaligen Einstellung von Datum und Uhrzeit wird auch das Inbetriebnahmedatum eingestellt. Dieses wird für die Berechnung des ersten Kalibrierungsintervalls verwendet (siehe „Einstellung des Kalibrierungsintervalls“ im Abschnitt „Erweiterte Konfiguration“).*

1. Im Menü „Settings“ mit den Tasten **AUF ▲** / **AB ▼** die Option **SET DATE/TIME** wählen und anschließend die Taste **EINGABE ↵** drücken.
2. Die Anzeige SET DATE erscheint. Die Jahreszahl ist hervorgehoben.
3. Mit den Tasten **AUF ▲** / **AB ▼** das Jahr einstellen und anschließend die Taste **EINGABE ↵** drücken, um den Monat zu wählen.
4. Mit den Tasten **AUF ▲** / **AB ▼** den Monat einstellen und anschließend die Taste **EINGABE ↵** drücken, um den Tag zu wählen.
5. Mit den Tasten **AUF ▲** / **AB ▼** den Tag einstellen und anschließend die Taste **EINGABE ↵** drücken.



6. Die Anzeige SET TIME erscheint. Die Stundenzahl ist hervorgehoben.
7. Mit den Tasten **AUF** ▲ / **AB** ▼ die Stunde einstellen und anschließend die Taste **EINGABE** ↵ drücken, um die Minuten zu wählen.
8. Mit den Tasten **AUF** ▲ / **AB** ▼ die Minuten einstellen und anschließend die Taste **EINGABE** ↵ drücken, um die Sekunden zu wählen.
9. Mit den Tasten **AUF** ▲ / **AB** ▼ die Sekunden einstellen und anschließend die Taste **EINGABE** ↵ drücken.
10. Die Uhr ist nun eingestellt und das Menü „Configure“ wird angezeigt.

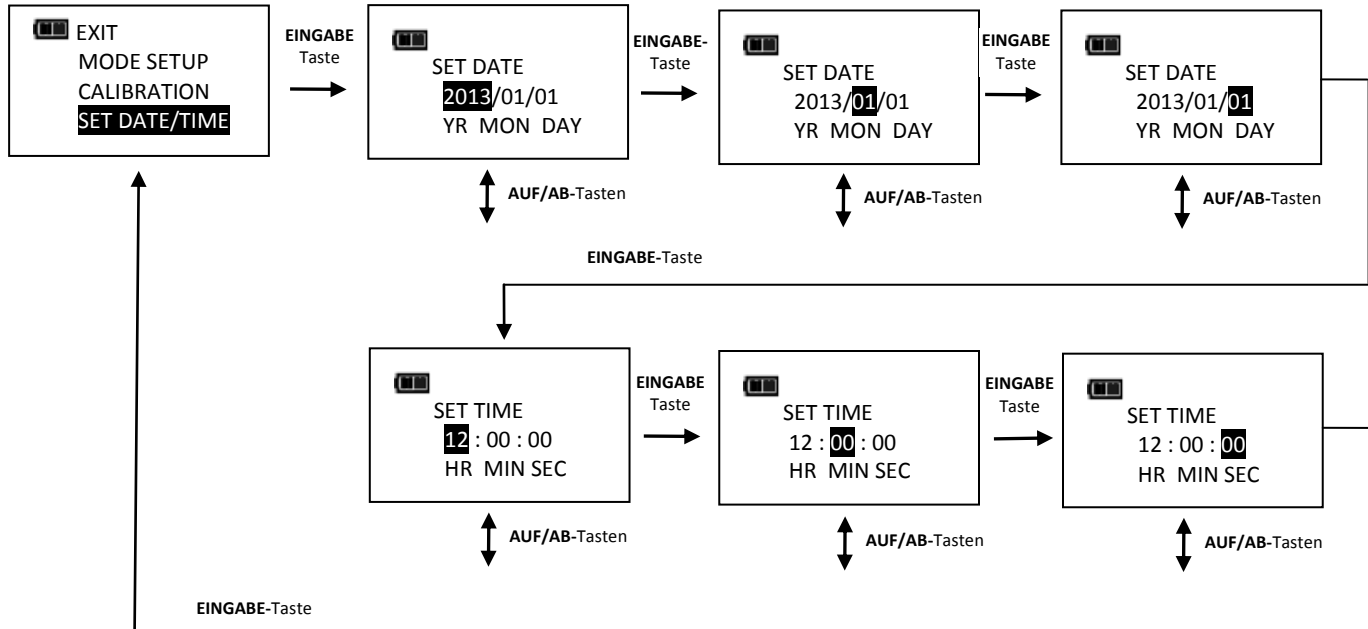

*Hinweis: Das Jahr wird ab 2013 hochgezählt. Der Monat wird von 1 bis 12 gescrollt. Der Tag wird von 1 bis 31 gescrollt.*

*Hinweis: Die Stunde wird von 0 bis 23 gescrollt. Die Minuten und Sekunden werden von 0 bis 59 gescrollt.*

*Hinweis: Werden die Batterien länger als 20 Minuten aus dem Schlüssel entfernt, kehrt die Uhr wieder zu den Standardeinstellungen zurück und muss beim Einschalten erneut eingestellt werden.*

### Einstellung des Kalibrierintervalls

Diese Funktion ermöglicht dem Benutzer, das Kalibrierungsintervall einzustellen, nach dem die Meldung „CAL NEEDED“ angezeigt wird.

1. Im Menü „Settings“ mit den Tasten **AUF** ▲ / **AB** ▼ die Option **SET CAL INTRVAL** wählen und anschließend die Taste **EINGABE** ↵ drücken.
2. Die Anzeige CAL INTERVAL erscheint.
3. Mit den Tasten **AUF** ▲ / **AB** ▼ das Kalibrierungsintervall ändern.

Wählbare Intervalle:

- DISABLED (deaktiviert, Werkseinstellung)
- 3 MON
- 6 MON
- 12 MON

4. Die Taste **EINGABE** ↵ drücken, um die Auswahl zu übernehmen und das Menü „Configure“ zu verlassen.

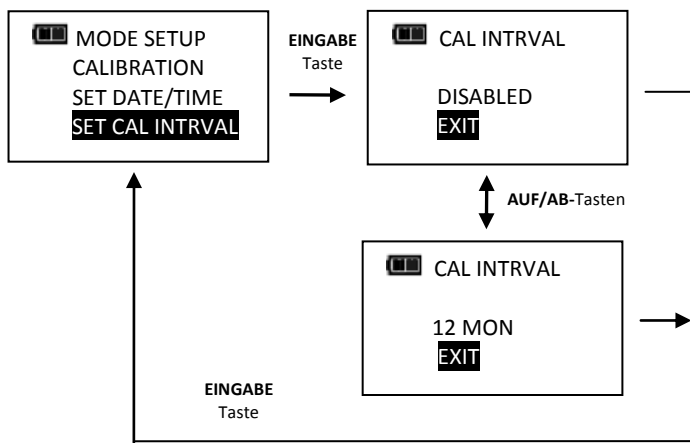





*Hinweis: Bevor das Kalibrierungsintervall wirksam wird, müssen Datum und Uhrzeit eingestellt werden. Werden die Batterien länger als 20 Minuten aus dem Schlüssel entfernt, kehrt die Uhr wieder zu den Standardeinstellungen zurück und muss beim Einschalten erneut eingestellt werden.*







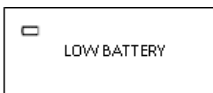

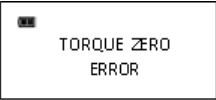
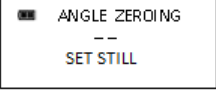
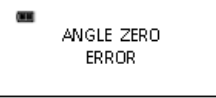

*Hinweis: Das Kalibrierungsintervall wird entweder ab dem Inbetriebnahmedatum oder dem letzten Kalibrierungsdatum (siehe Menü SHOW INFO) berechnet, je nachdem, welches Datum das jüngere ist. Wenn das aktuelle Datum nach dem Inbetriebnahmedatum bzw. dem letzten Kalibrierungsdatum plus dem Kalibrierungsintervall liegt, erscheint nach dem Einschalten und nach dem Nullstellen die Meldung „CAL NEEDED“. Durch Drücken der Taste **EINGABE** wird das Sollwert-Menü angezeigt. Bei Verwendung des Drehmomentschlüssels während „CAL NEEDED“ angezeigt wird, wird sofort die Drehmoment- oder Winkelmessung angezeigt und bei Kraftaufhebung das Sollwert-Menü aufgerufen.*

*Hinweis: Als Alternative zum Kalibrierungsintervall befindet sich im Kalibrieremenü ein Kalibrierzykluszähler (kontaktieren Sie Ihr örtliches Snap-on-Reparatur-Center bezüglich des Kalibrieremenüs).*

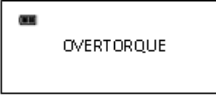
## • Fehlerbehebung

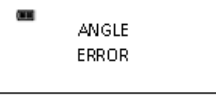
*Hinweis: Sollte das betreffende Problem bestehen bleiben, schicken Sie den Drehmomentschlüssel an ein autorisiertes Snap-on-Reparatur-Center ein.*

Problem	Mögliche Ursache	Behebung
Schlüssel schaltet nicht ein, wenn die Taste <b>EIN/AUS</b>  betätigt wird	Batterien leer oder nicht vorhanden	Batterien ersetzen
	Softwarefehler	Mittels Verschlusskappe aus-/einschalten
Drehmoment-Messwert außerhalb der Spezifikation	Kalibrierung erforderlich	Neu kalibrieren
	Falsche Kopflänge eingegeben	Richtige Versatz-Kopflänge eingeben
Einstellungen wurden beim Herausnehmen der Batterien gelöscht	Batterien wurden entfernt, bevor die Einstellungen im nicht-flüchtigen Speicher abgelegt wurden.	Die Einstellungen neu eingeben und die Taste <b>EIN/AUS</b>  gedrückt halten, um den Schlüssel auszuschalten, bevor die Batterien herausgenommen werden
Drehmoment oder Winkel angezeigt, obwohl kein Drehmoment aufgebracht wird	Drehmoment oder Winkel wird auf null gestellt, während ein Drehmoment aufgebracht wird	Schlüssel ohne Aufbringen eines Drehmoments auf eine stabile Oberfläche legen und die Taste <b>EIN/AUS</b>  drücken, um den Schlüssel auf null zu stellen
	Niedrige Batterieladung	Taste <b>EINGABE</b>  drücken, um den Schlüssel weiter zu verwenden, und die Batterien in Kürze auswechseln

Problem	Mögliche Ursache	Behebung
	Batterie leer	Taste <b>EIN/AUS</b>  drücken, um den Schlüssel auszuschalten, und die Batterien auswechseln
	Drehmoment beim Nullstellen aufgebracht	Drehmoment lösen und auf null stellen
	Schlüssel überdreht	Neu kalibrieren
	Schlüssel falsch kalibriert	Neu kalibrieren
	Fehler des Drehmomentaufnehmers	An Snap-on-Reparatur-Center einschicken
	Schlüssel bewegt sich bei Nullstellung	Schlüssel auf eine stabile Oberfläche legen
	Kreisel instabil	An Snap-on-Reparatur-Center einschicken
	Taste <b>EIN/AUS</b>  beim Winkel-Nullstellen gedrückt (Nullstellung abgebrochen, um Menü aufzurufen)	Schlüssel auf eine stabile Oberfläche legen und die Taste <b>EIN/AUS</b>  drücken, um den Schlüssel auf null zu stellen
	Drehmoment mit mehr als 125 % der Gesamtskala aufgebracht	Schlüssel durch Drücken der Taste <b>EIN/AUS</b>  aus- und wieder einschalten und neu kalibrieren
	Schlüssel bei Winkelmessung zu schnell gedreht	Schlüssel auf eine stabile Oberfläche legen und die Taste <b>EIN/AUS</b>  drücken, um den Schlüssel auf null zu stellen
	Speicherfehler	Datenspeicher löschen
	Drehmoment unkalibriert	Drehmoment kalibrieren
	Winkel unkalibriert	Winkel kalibrieren

## • VERWENDUNG VON ADAPTERN, VERLÄNGERUNGEN UND UNIVERSALSPANNERN

Wird der Drehmomentschlüssel mit einem Adapter, einer Verlängerung oder einem Universalspanner verwendet, wobei der Abstand des Befestigungselements vom Abstand des Vierkant-Antriebsteils des Drehmomentschlüssels bei der Kalibrierung verschieden ist, muss die Kopflänge geändert werden, um eine einwandfreie Drehmomentmessung für das Befestigungselement zu erhalten.

Bei Verwendung einer Wobbel-Verlängerung oder eines Universalspanners darf der Versatz nicht mehr als 15 Grad vom senkrechten Antriebsteil abweichen. Keine lange Verlängerung mit Flex-Antrieb bei voller Ausladung verwenden.

## • KALIBRIERUNG

Wenden Sie sich zwecks Kalibrierung an Ihre Service-Vertretung für Snap-on-Werkzeuge.

## • ZERTIFIZIERUNG

Die Kalibrierung dieses TechAngle® Drehmomentschlüssels erfolgte im Werk mittels Winkelverstell- und Drehmomentmessgeräten gemäß dem National Institute of Standards and Technology (NIST). Die Drehmoment-Parameter entsprechen ISO 6789-2003 und ASME B107-28-2010. Hinweis: Für Winkelschlüssel bestehen keine US-amerikanischen oder internationalen Standards.

**WICHTIG!** Kalibrierungen werden im Speicher des Schlüssels aufgezeichnet zum Nachweis bei Erlöschen der Werkszertifizierung.

## • WARTUNG / INSTANDHALTUNG

Schlüssel durch Abwischen mit einem feuchten Tuch reinigen. KEINE Lösungsmittel, Verdüner oder Vergaserreiniger verwenden.

NICHT in Flüssigkeiten tauchen.

Instandhaltung, Reparatur und Kalibrierung dürfen nur von einem Snap-on-Service-Center durchgeführt werden. Wenden Sie sich an Ihren Fachhändler für Snap-on-Werkzeuge.

Der Ratschenkopf kann von einem Fachhändler für Snap-on-Werkzeuge oder dem Benutzer repariert werden.

## • Batteriewechsel

### Nur durch drei Zellen der Größe AA ersetzen.

- Die Alkali-Zellen nicht wiederaufzuladen versuchen.
- Verschiedene Batterietypen nicht miteinander mischen.
- Alle Batterien gleichzeitig ersetzen.
- Den Schlüssel an einem trockenen Ort aufbewahren.
- Die Batterien entfernen, wenn der Schlüssel länger als 3 Monate nicht verwendet wird.

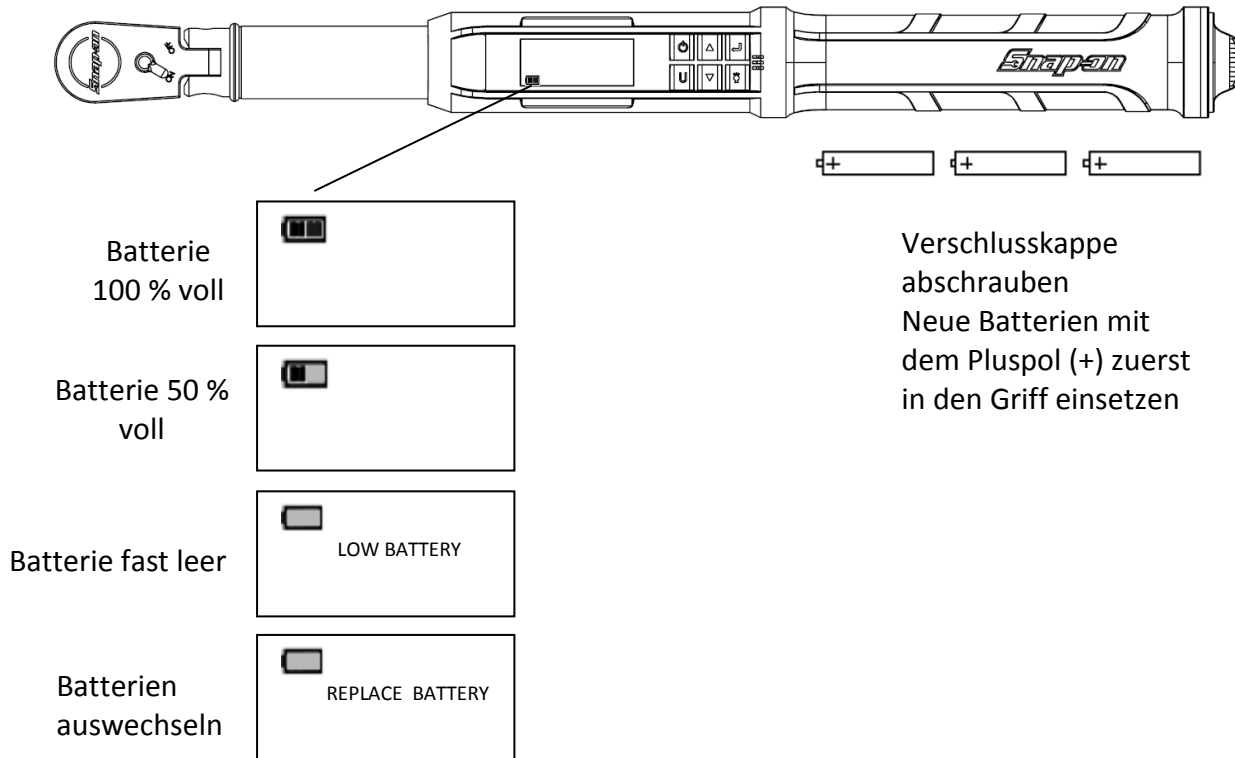

*Hinweis: Nach dem Herausnehmen der Batterien bleibt die Einstellung von Datum und Uhrzeit für 20 Minuten erhalten.*

*Hinweis: Verschlusskappe gegen den Uhrzeigersinn abschrauben.*



*Hinweis: Bei Anzeige von „Replace Battery“ funktioniert der Schlüssel erst wieder, wenn die Batterien ausgewechselt wurden. Es funktioniert nur die Taste **EIN/AUS** , mit der der Schlüssel sofort ausgeschaltet wird.*

## • Speicher-Anzeigen

Daten im Speicher		Weniger als 50 Drehmoment- und Winkel-Datensätze
Speicher voll		50 Drehmoment- und Winkel-Datensätze gespeichert. Der älteste Datensatz wird durch den nächsten Datensatz ersetzt.
Speicher-Fehler		Speicher-Fehler beim Lesen oder Schreiben. Tritt dieser Fehler nach Löschen des Speichers weiterhin auf, das Gerät an ein Snap-on Reparatur-Center einschicken.

# AUTORISIERTE SNAP-ON REPARATUR-CENTER

## USA

### **Reparatur-Center Ost**

6320 Flank Drive  
Harrisburg, PA 17112  
Telefon: +1-717-652-7914  
Fax: +1-717-652-7123

### **Reparatur-Center Nord**

3011 E. State Rt. 176, Dock A  
Crystal Lake, IL 60014  
Telefon: +1-815-479-6850  
Fax: +1-815-479-6857

### **Reparatur-Center West**

2151 Challenger Way  
Carson City, NV 89706-0753  
Telefon: +1-775-883-8585  
Fax: +1-775-883-8590

## KANADA

### **Reparatur-Center West**

7403-48 Street SE  
Calgary, Alberta  
Kanada, T2C-4H6  
Telefon: +1-403-720-0525  
Fax: +1-403-720-0524

## INTERNATIONAL

### **Reparatur-Center Großbritannien**

Telford Way  
Telford Way Industrial Estate  
Kettering, Northants  
NN16 8UN England  
Telefon: +44-1-536-413855.  
Fax: +44-1-536-413900.

### **Reparatur-Center Australien**

Snap-on Tools Australia PTY.LTD  
Unit 6/110 Station Road  
Seven Hills, NSW 2147  
Australien  
Telefon: +61-2-8937-9155  
Fax: +61-2-9624-2445

### **Reparatur-Center Singapur**

Snap-on Tools Singapore PTE Ltd  
128 Tagore Lane, Blk 4 Singapore  
787554 Republic of Singapore  
Telefon: +65-451-5570  
Fax: +65-451-5574

### **Reparatur-Center Japan**

Snap-on Tools Japan K.K.  
3-5-12 Konan  
Minato-ku, Tokyo 108  
Japan  
Telefon: +81-3-5463-1280  
Fax: +81-3-5463-1284

### **Snap-on/SUN De Mexico**

S.A. De C.V.  
Avenida Presidente Juarez No.  
2016  
Col Los Reyes Zona Industrial  
Tlalnepantla Edo De Mexico  
CP54070 MEXICO  
Telefon: +52-55-53903122  
Fax: +52-55-53903259

#### WICHTIGE HINWEISE ZUM UMWELTSCHUTZ:



1. DIESES GERÄT KANN GEFAHRSTOFFE ENTHALTEN, DIE SCHÄDLICH FÜR DIE UMWELT SIND.
2. DIESES GERÄT NICHT ALS HAUSMÜLL ENTSORGEN, SONDERN AN DEN HÄNDLER ZURÜCKGEBEN ODER EINER DAFÜR VORGESEHENEN SAMMELSTELLE ZUFÜHREN.

DANKE FÜR DIE ERHALTUNG DER UMWELT!

**Snap-on Tools Company**

Kenosha, WI 53141-1410 USA



Gedruckt in den USA

# **BELANGRIJKE VEILIGHEIDSINSTRUCTIES**



## **WAARSCHUWING *Risico van wegvliegende fragmenten.***

Te ver aandraaien kan breuk veroorzaken. Forceren voorbij de flex-aanslagposities op de flex-kop kan leiden tot breuk van de kop. Een verkeerd gekalibreerde hoeksleutel kan breuk van onderdelen of gereedschappen veroorzaken. Defecte handgereedschappen, doppen en accessoires kunnen letsel veroorzaken. Bij gebruik van teveel kracht kan een steeksleutel of open ringsleutel slippen.

- Lees deze handleiding **helemaal** door voordat u de ELEKTRONISCHE SLEUTEL gebruikt.
- Voor een nauwkeurige prestatie mag het werkstuk in de hoekmodus niet bewegen.
- Volg voor uw persoonlijke veiligheid en om beschadiging van de sleutel te voorkomen altijd de juiste professionele methoden bij het gebruik van gereedschappen en de installatie van bevestigingsmateriaal.
- Voor het behoud van de nauwkeurigheid is regelmatige kalibratie vereist.
- Draag een veiligheidsbril, dit geldt zowel voor gebruiker als omstanders.**
- Zorg dat alle componenten (inclusief verloopstukken, verlengstukken, schachten en doppen) ten minste zijn goedgekeurd voor het gebruikte koppel.
- Neem bij gebruik van deze sleutel alle waarschuwingen, aandachtspunten en procedures voor de apparatuur, voor het systeem en van de fabrikant in acht.



- Gebruik doppen van de juiste maat voor het bevestigingsmateriaal.
- Gebruik nooit doppen die versleten of gebarsten zijn.
- Vervang bevestigers waarvan de hoeken gestript zijn.
- Voorkom beschadiging van de sleutel:** Gebruik de sleutel nooit terwijl hij is uitgeschakeld. Zet de sleutel altijd AAN zodat het uitgeoefende koppel wordt gemeten.



- Druk niet op **STROOM**  terwijl u iets aantrekt of terwijl de sleutel beweegt.
- Gebruik deze sleutel nooit om bevestigers met geweld los te halen.
- Gebruik geen verlengstukken (bijv. een stuk pijp) op de greep van de sleutel.
- Controleer of de capaciteit van de sleutel voldoende is voor het beoogde gebruik voordat u aan de slag gaat.
- Controleer de kalibratie als de sleutel is gevallen.
- Zorg dat de ratelrichtingspal goed in de juiste stand staat.
- Controleer de kalibratie van de sleutel als u weet of vermoedt dat de capaciteit ervan is overschreden.
- Druk de kop van sleutels met flexibele kop niet met kracht tegen aanslagen aan.
- Trek altijd aan de sleutelgreep (duw er niet tegen) en ga zo staan dat u niet kunt vallen als een onderdeel plotseling meegeeft.
- Probeer niet om de alkaliceelbatterijen op te laden.
- Bewaar de sleutel op een droge plaats.
- Verwijder de batterijen als u de sleutel langer dan 3 maanden opbergt.



## **WAARSCHUWING *Gevaar van elektrische schokken.***

Elektrische schokken kunnen letsel veroorzaken. De kunststof greep is niet geïsoleerd.

Niet gebruiken op onder stroom staande circuits.

## **BEWAAR DEZE GEBRUIKSAANWIJZING**

### **Disclaimer**

Er geldt geen garantie voor het gebruik van de TechAngle<sup>®</sup>-sleutel in lidstaten van de EU als de gebruiksaanwijzing niet in de taal van het land in kwestie beschikbaar is. Neem contact op met Snap-on voor vertalingen.

# Specificaties

## Type kop

- Vierkant, 72 of 80 tanden, verzegeld flex

## Display

- TYPE DISPLAY: Dot-matrix lcd (resolutie 192 x 65)
- GEZICHTSHOEK: 6:00
- SCHERMVERLICHTING: WIT (led)

## Verzegeld toetsenblok



**STROOM** - AAN/UIT en nulinstelling koppel en hoek



**ENTER** - selectie van meetmodus en menu-invoer



**OMHOOG** – verhoogt koppel- en hoekinstelling, en omhoog in menu



**OMLAAG** - verlaagt koppel- en hoekinstelling, en omlaag in menu



**EENHEDEN** - selectie van eenheden (ft-lbs, in-lbs, Nm, Kgm, Kg-cm, dNm) en openen van het menu PSET (voorinstellingen)



**LCD-VERLICHTING** – verlicht alle schermen, en voor ophalen van laatste piekmoment of hoek

## Functies

- Instellen – streefwaarde voor moment of hoek
- Track – real time-weergave van moment of geaccumuleerde draaihoek met voortgangslampjes
- Piekbehoud – 10 seconden lang knipperende weergave van piekkoppel of afwisselend piekkoppel/hoek na wegnemen van het koppel
- Piekgeheugen – weergave van laatste piekkoppel of piekkoppel/hoek na indrukken van knop
- Geheugen – weergave van de 50 laatste piekkoppels of piekkoppel/hoekwaarden

## Nauwkeurigheid

- Temperatuur: bij 22 °C (72 °F)
- Hoek: ± 1% van meetwaarde ± 1° bij hoeksnelheid > 10°/s < 180°/s ± 1° van testarmatuur

RECHTSOM LINKSOM

- Koppel: 

{	±2%	±3%	van meetwaarde, 20% tot 100% van volledige schaal
	±4%	±6%	van meetwaarde, 10% tot 19% van volledige schaal
	±8%	±10%	van meetwaarde, 5% tot 9% van volledige schaal

## Afmetingen: Lengte/gewicht

Model	Lengte	Gewicht
ATECH1FR240B	16,4 in.	1,9 lb.
ATECH2FR100B	17,9 in.	2,3 lb.
ATECH3FR250B	26,6 in.	3,7 lb.

## Voorinsteld bereik

- HOEK: 0 tot 360° rechts- of linksom (displayresolutie 1°)
- KOPPEL: (Weergavebereik en -resolutie zoals hieronder weergegeven)

Model	Vierkant	ft-lb	in-lbs	Nm	Kgm	kg-cm	dNm	overbel.(ft-lb)
ATECH1FR240B	¼ in.	1.00-20.00	12.0-240.0	1.36-27.12	n.v.t.	13.8-276.5	13.6-271.2	25
ATECH2FR100B	⅜ in.	5.0-100.0	60-1200	6.8-135.6	n.v.t.	69-1383	68-1356	125
ATECH3FR250B	½ in.	12.5-250.0	150-3000	16.9-339.0	1.73-34.56	n.v.t.	n.v.t.	312

<b>Bedrijfstemperatuur:</b>	-18 °C tot 54 °C (0 °F tot 130 °F)
<b>Opslagtemperatuur:</b>	-18 °C tot 54 °C (0 °F tot 130 °F)
<b>Meetverschuiving:</b>	HOEK: -0,12 gradenhoek per graad C KOPPEL: +0,01% van meetwaarde per graad C
<b>Vochtigheidsgraad:</b>	Maximaal 90%, niet-condenserend
<b>Batterij:</b>	Drie AA alkaliceelbatterijen, maximaal 40 uur continu bedrijf
<b>Standaard automatische uitschakeling:</b>	Na 2 minuten zonder gebruik – (instelbaar: zie 'Geavanceerde instellingen')



# Gebruiksaanwijzing

## • Basisfuncties (snelstart)

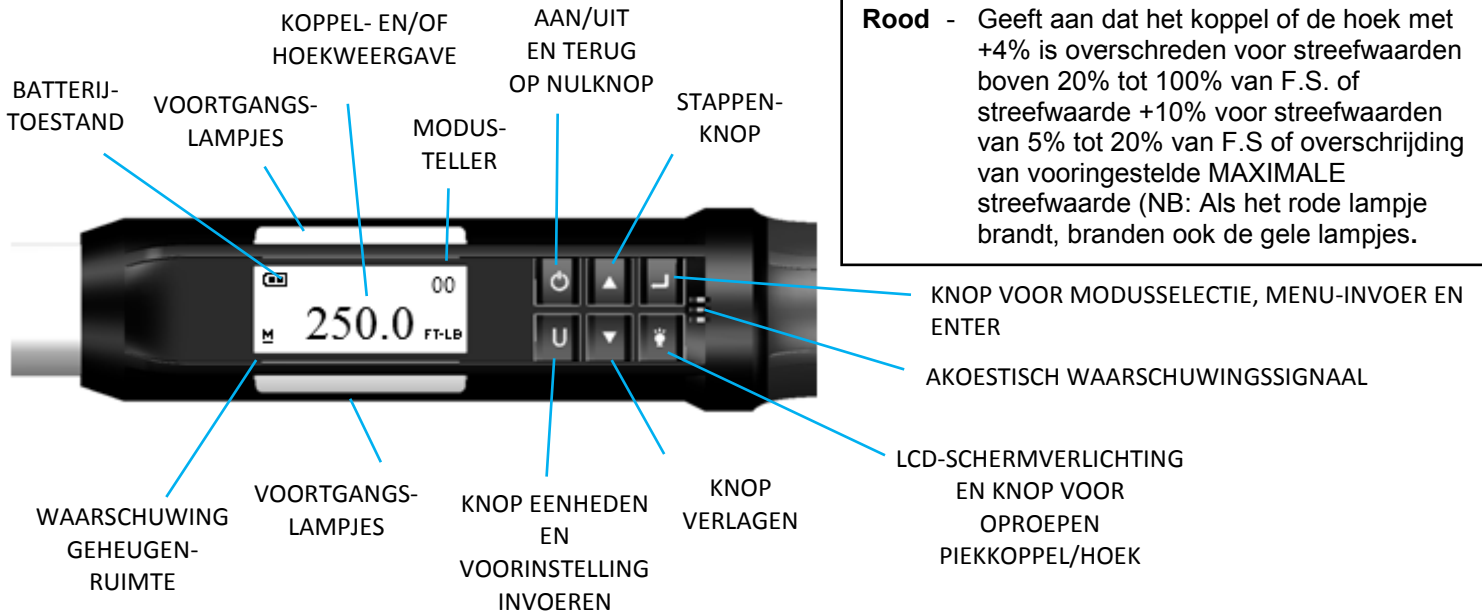

**VOORTGANGSLAMPJES**  
**Geel** - Eerste lampje geeft bereik van 40% van streefkoppel/-hoek weer, tweede 60%, derde 80%.  
**Groen** - Geeft aan dat het beoogde koppel of de beoogde hoek is verkregen.  
**Rood** - Geeft aan dat het koppel of de hoek met +4% is overschreden voor streefwaarden boven 20% tot 100% van F.S. of streefwaarde +10% voor streefwaarden van 5% tot 20% van F.S. of overschrijding van vooringestelde MAXIMALE streefwaarde (NB: Als het rode lampje brandt, branden ook de gele lampjes).

Afbeelding 1

Installeer drie nieuwe AA-batterijen in de sleutelgreep.

### Inschakelprocedure sleutel

Opm.: Zet de sleutel niet aan wanneer u koppel aanlegt, omdat de nul-offset voor het koppel dan onjuist zal zijn en de sleutel bij het loslaten geen momentwaarde zal aangeven. Zet de sleutel in dat geval weer op nul door op de knop **STROOM** te drukken terwijl de sleutel op een stabiele ondergrond ligt en er geen koppel wordt aangelegd.

1. Zet de sleutel aan.

Druk kort op de knop **STROOM** . Het Snap-on-logo wordt weergegeven, gevolgd door het scherm voor nulinstelling van het koppel. Als de vorige meetwaarde een hoekwaarde was, wordt het nulinstellingsscherm voor het koppel gevolgd door dat voor de hoek. Na de nulinstelling wordt het scherm met de streefwaarde voor koppel of hoek weergegeven, afhankelijk van de vorige meetmodus.

2. Selecteer een meetmodus.



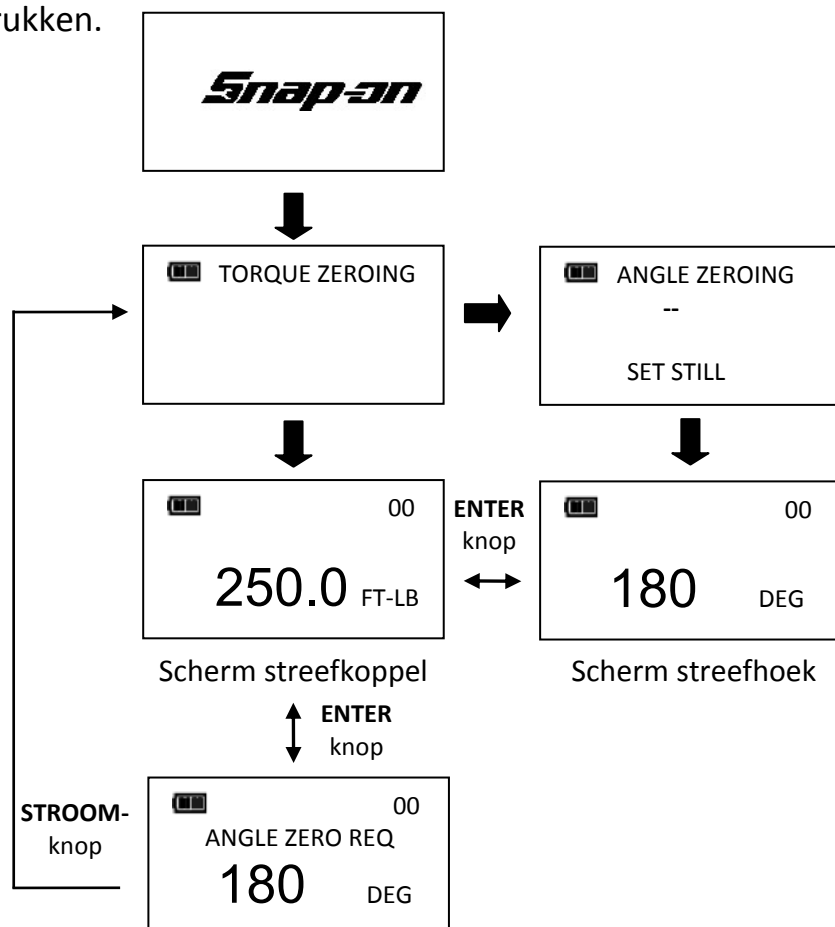





U schakelt heen en weer tussen de schermen voor KOPPEL en HOEK door herhaaldelijk op de knop **ENTER** te drukken.



*Opm.: Als de sleutel wordt aangezet in de modus waarin alleen het koppel wordt gemeten, wordt de hoek pas op nul ingesteld als op de hoekmeetmodus wordt overgeschakeld. De nulinstelling van het koppel en de hoek begint dan automatisch binnen 2 seconden. Leg de sleutel op een stabiele ondergrond zonder koppel uit te oefenen.*



*Opm.: Als u op de knop **ENTER**  drukt tijdens de nulinstelling van de hoek, wordt de nulinstelling afgebroken en kunt u een andere meetmodus selecteren.*

## Koppelmodus

1. Stel de streefwaarde in.  
Gebruik de knoppen **OMHOOG** /**OMLAAG**  om de streefwaarde voor het KOPPEL in te stellen.
2. Selecteer de te gebruiken maateenheid.  
Druk herhaaldelijk op de knop **EENHEDEN**  op het scherm voor streefwaarde KOPPEL totdat de gewenste eenheid wordt weergegeven.
3. Oefen KOPPEL uit.  
Pak het midden van de greep beet (NIET aan het batterijdeksel op het uiteinde trekken) en haal de bevestiging langzaam aan totdat de voortgangslampjes groen branden en een geluidssignaal van een halve seconde en trilling van de greep aangeven dat u moet stoppen.
4. Stop met het uitoefenen van KOPPEL.  
Lees de waarde van het piekKOPPEL af, die 10 seconden lang op de lcd-display knippert. Als u op de knop **VERLICHTING**  drukt terwijl het piekkoppel knippert, wordt de waarde weergegeven totdat u de knop weer loslaat. Druk kort op de knop **OMHOOG** /**OMLAAG** , **ENTER**  of **EENHEDEN**  om direct terug te gaan naar het scherm met het streefKOPPEL. Als u opnieuw KOPPEL uitoefent, wordt er direct een nieuwe cyclus voor meting van het KOPPEL gestart.
5. Haal de gemeten piekKOPPEL-waarde op  
Om het laatste gemeten piekKOPPEL op te halen, drukt u de knop **VERLICHTING**  circa 3 seconden in. De piekKOPPELwaarde blijft 10 seconden knipperen.

## Hoekmodus

*Opm.: Oefen geen koppel uit tijdens nulinstelling van het koppel en de hoek, anders zal de nul-offset voor het koppel onjuist zijn en geeft de sleutel een hoekwaarde weer als er geen koppel wordt uitgeoefend. Zet de sleutel in dat geval weer op nul door kort op de knop **STROOM**  te drukken terwijl de sleutel op een stabiele ondergrond ligt en er geen koppel wordt aangelegd.*

1. Nulinstelling hoek  
Wacht bij het bericht 'ANGLE ZERO REQ' (nulinstelling hoek vereist) 2 seconden totdat de automatische nulinstelling van de hoek is voltooid voordat u koppel uitoefent of de sleutel beweegt.
2. Stel de streefwaarde in.  
Gebruik de knoppen **OMHOOG** /**OMLAAG**  om de streefwaarde voor de HOEK in te stellen.
3. Oefen koppel uit en draai de sleutel.  
Pak het midden van de greep beet (NIET aan het batterijdeksel op het uiteinde trekken) en draai de sleutel gelijkmatig maar niet te snel totdat de voortgangslampjes groen branden en een geluidssignaal van een halve seconde en trilling van de greep aangeven dat u moet stoppen.
4. Stop met het uitoefenen van koppel.  
Lees de waarde van het piekKOPPEL en de HOEK af, die 10 seconden lang op de lcd-display knipperen. Als u op de knop **VERLICHTING**  drukt terwijl de piekhoek knippert, wordt de waarde weergegeven totdat u de knop weer loslaat. Druk kort op de knoppen **OMHOOG** /**OMLAAG** , **ENTER**  of **EENHEDEN**  om direct terug te gaan naar het scherm met de streefHOEK. Als u opnieuw koppel uitoefent (ratelt) voordat het

streefwaardescherm wordt weergegeven, wordt de HOEK verder gemeten tijdens het draaien van de sleutel.

#### 5. Haal de gemeten piekHOEK-waarde op

Om de laatste gemeten piekHOEK op te halen, drukt u de knop **VERLICHTING**  circa 3 seconden in. Het piekKOPPEL en de piekHOEK worden 10 seconden lang afwisselend weergegeven.

### Cyclustelling in de modi

De TechAngle<sup>®</sup>-functie voor telling van de cycli in de twee modussen wordt gebruikt om aan te geven hoe vaak de sleutel het piekkoppel heeft bereikt in de koppelmeetmodus of de streefhoek in de hoekmeetmodus.

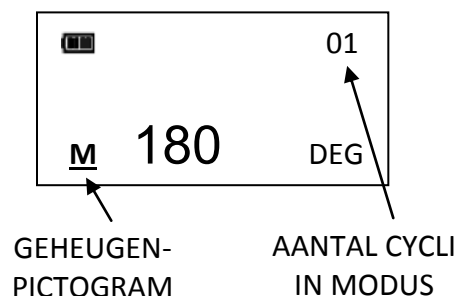

### Telling van cycli in koppel- en hoekmodus

4. Een teller rechtsboven op het piekkoppel- of piekhoekscherm telt op na elke koppel- of hoekcyclus als het uitgeoefende koppel of de hoek de streefwaarde heeft bereikt.
5. Als u met de knop **ENTER**  op de andere modus overschakelt of als u de streefwaarde wijzigt, wordt de teller weer teruggezet op 00. De teller wordt NIET teruggezet bij hernieuwde nulinstelling, na het openen of afsluiten van het menu, of als de sleutel wordt uitgezet.
6. Het geheugenpictogram wordt weergegeven als er koppel- of hoekgegevens in het geheugen zijn opgeslagen.

### Hoofdmenu

In het hoofdmenu wordt informatie over de werking van de sleutel weergegeven.

1. Druk vanuit het streefkoppel- of streefhoekscherm 3 seconden lang op de knop **ENTER** .
2. Gebruik de knoppen **OMHOOG** /**OMLAAG**  om de menu-optie te markeren en druk dan op de knop **ENTER** .





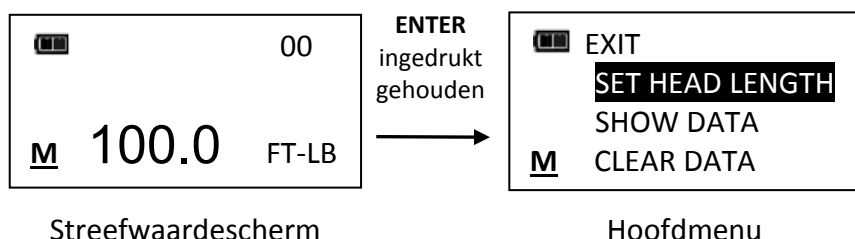





Menu-opties:

- EXIT (afsluiten) – Sluit het hoofdmenu af; het streefwaardescherm wordt weergegeven.
  - SET HEAD LENGTH (koplengte instellen) – Opent het scherm voor invoer van de lengte van de kop van de sleutel.
  - SHOW DATA (gegevens weergeven) – Geeft de opgeslagen koppel- en hoekgegevens weer.
  - CLEAR DATA (gegevens wissen) – Wist de opgeslagen koppel- en hoekgegevens.
  - CYCLE COUNT (aantal cycli) – Geeft het scherm voor telling van het aantal koppel- en hoekcycli weer.
  - SETTINGS (instellingen) – Geeft het menu voor geavanceerde instellingen weer (zie paragraaf 'Geavanceerde instellingen').
  - CONFIGURE (configureren) – Geeft het menu voor geavanceerde configuratie weer (zie paragraaf 'Geavanceerde configuratie').
3. Om het hoofdmenu af te sluiten en terug te gaan naar het koppel- of hoekscherm, drukt u op de knop **ENTER**  terwijl de menu-optie **EXIT** gemarkeerd is.



## Koplenge instellen

*Opm.: Als er een verloop- of verlengstuk op de sleutel wordt gebruikt, kan de lengte van dat verloop- of verlengstuk in de sleutel worden ingevoerd om de sleutel te gebruiken zonder deze opnieuw te kalibreren.*

1. Om vanuit het streefkoppel- of streefhoekscherf een koplenge in te voeren, drukt u 3 seconden lang op de knop **ENTER** .
2. Druk kort op de knop **ENTER**  terwijl de menu-optie **SET HEAD LENGTH** (koplenge instellen) is gemarkeerd.
3. Het scherm Set Head Length (koplenge instellen) wordt nu weergegeven. De standaard koplenge is de koplenge ten tijde van de kalibratie. Gebruik de knoppen **OMHOOG**  / **OMLAAG**  om de koplenge te verhogen/verlagen.
4. Als u de knoppen **OMHOOG**  / **OMLAAG**  ingedrukt houdt, wordt de waarde sneller verhoogd/verlaagd. Als u tegelijkertijd op de knop **OMHOOG**  en **OMLAAG**  drukt, wordt de koplenge teruggezet op nul.
5. De standaard maateenheid voor de lengte is inches. Druk op de knop **EENHEDEN**  om dit in millimeter te veranderen.
6. Druk na het instellen van de lengte op de knop **ENTER**  om terug te gaan naar het hoofdmenu. Als de lengte anders is ingesteld dan de standaardwaarde, wordt het bericht 'OFFSET IN USE' (offset gebruikt) op het streefwaardescherf weergegeven

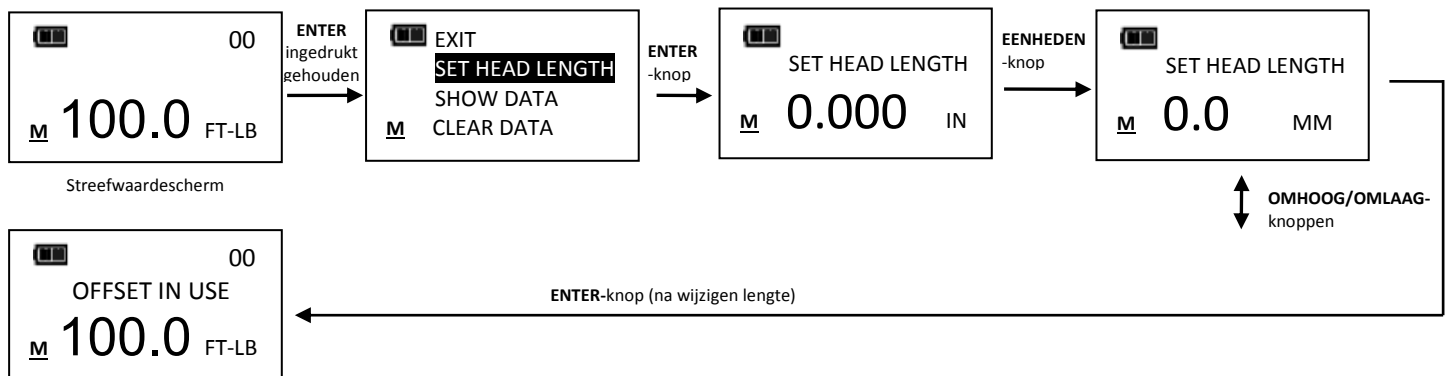

*Opm.: De ingevoerde koplenge is de offset-afstand, tussen het midden van de sleutel en het midden van de bevestigiger.*

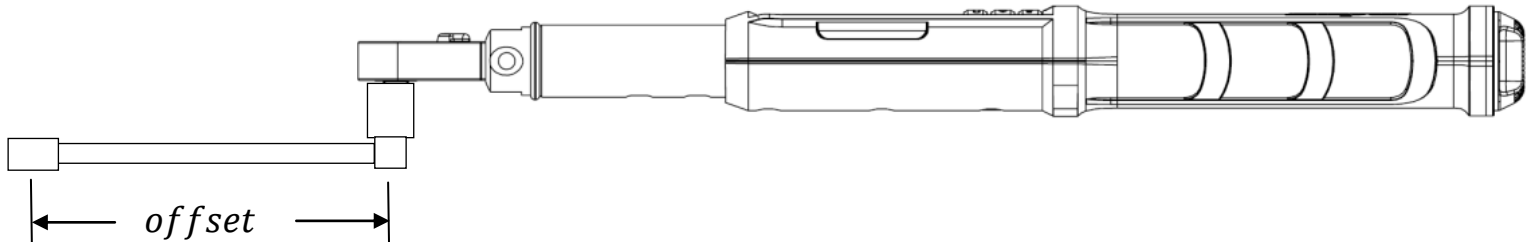

## Gebruik van negatieve offset-waarden

*Opm.: Voer voor de offset een negatieve waarde in als u de sleutel in omgekeerde richting gebruikt.*

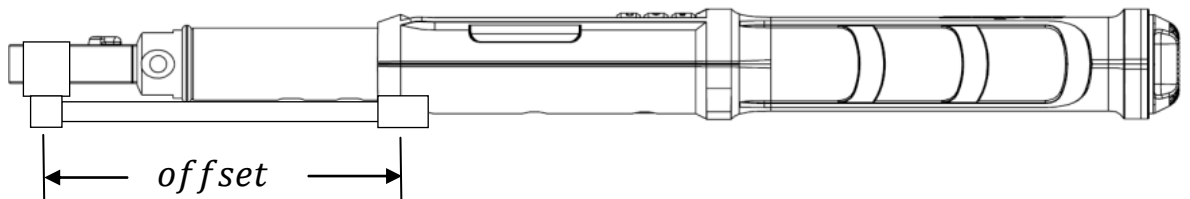

Als de offset-lengte een negatieve waarde is, gelden voor de maximale streefwaarde voor de bevestigiger de volgende formules:

240 in-lb sleutel:  
Maximaal streefkoppel =  
offset \* 24 + 240

Offset	Max streefwaarde
-1"	216 in-lb
-2"	192 in-lb
-3"	168 in-lb
-4"	144 in-lb

250 ft-lb sleutel:  
Maximaal streefkoppel =  
offset \* 12 + 250

Offset	Max streefwaarde
-1"	92 ft-lb
-2"	84 ft-lb
-3"	76 ft-lb
-4"	68 ft-lb







250 ft-lb wrench:  
Maximum Target Torque =  
offset \* 12 + 250

Offset	Max streefwaarde
-1"	238 ft-lb
-2"	226 ft-lb
-3"	214 ft-lb
-4"	202 ft-lb

*Opm.: Als u bij gebruik van een negatieve offsetwaarde een streefkoppel instelt dat groter is dan de hierboven vermelde maximale waarden, kan er een overkoppelfout worden gegeven voordat het streefkoppel voor de bevestigiger wordt gebruikt, waardoor de sleutel beschadigd kan raken.*

### Opgeslagen koppel- en hoekgegevens weergeven

De koppelgegevens worden na elke koppelcyclus in het geheugen opgeslagen als het uitgeoefende koppel de streefwaarde heeft bereikt. De koppel- en hoekgegevens worden na elke hoekcyclus in het geheugen opgeslagen als de gemaakte hoek de streefwaarde heeft bereikt. Als er gegevens zijn opgeslagen in het niet-vluchtige geheugen, wordt de geheugenindicator weergegeven.

1. Om vanuit het streefkoppel- of streefhoekscherf de opgeslagen koppel- en hoekgegevens weer te geven, drukt u 3 seconden lang op de knop **ENTER** .
2. Markeer de menu-optie **SHOW DATA** door op de knoppen **OMHOOG**  / **OMLAAG**  te drukken, en druk dan op de knop **ENTER**  om het scherm Show Data (gegevens weergegeven) te openen.
3. Loop in het scherm Show Data (gegevens weergegeven) door de opgeslagen gegevens door op de knoppen **OMHOOG**  / **OMLAAG**  te drukken.

Voorbeeld: 02 = Cijfer van item in lijst Show Data: TQ = Waarde piekkoppel



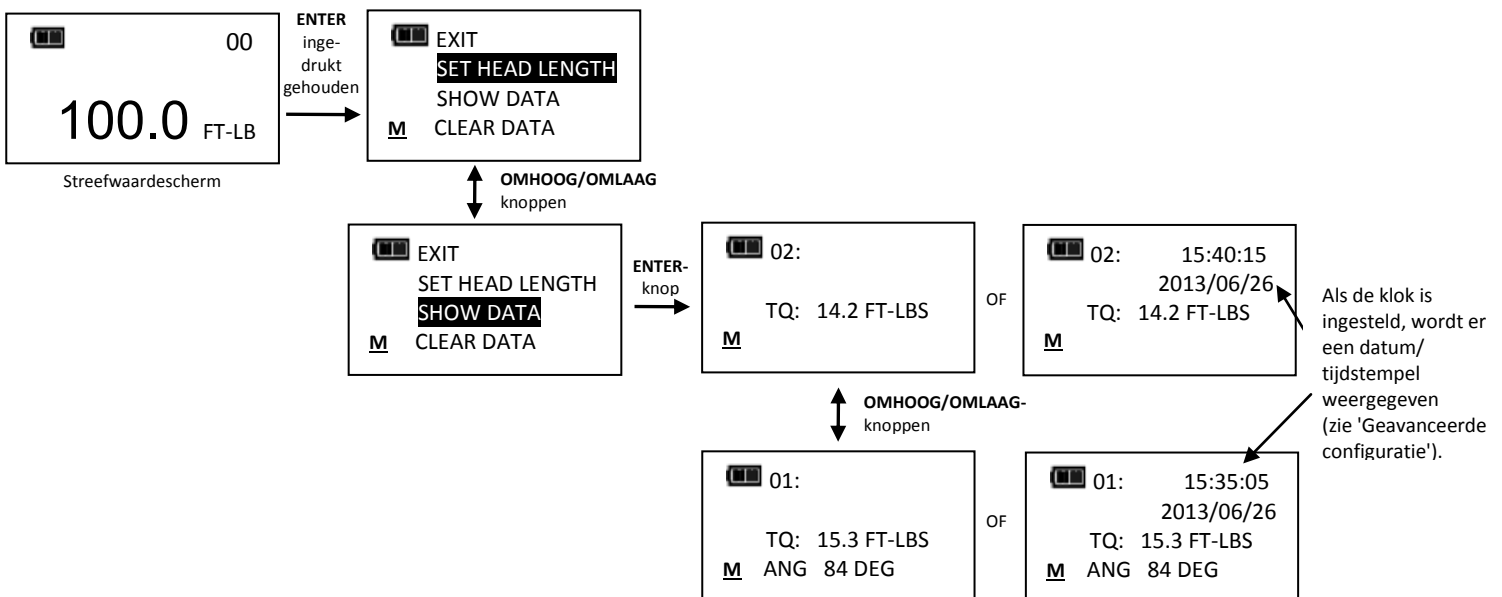

01 = Cijfer van item in lijst Show Data: TQ = Waarde piekkoppel: ANG = Waarde piekhoek

4. Als u in het scherm Show Data (gegevens weergegeven) op de knop **ENTER**  drukt, wordt het hoofdmenu weergegeven.



*Opm.: Er kunnen maximaal 50 gegevensrecords in het geheugen worden opgeslagen. Het pictogram voor vol geheugen wordt weergegeven als het geheugen vol is. De oude records worden door nieuwe gegevens overschreven totdat het geheugen wordt gewist.*





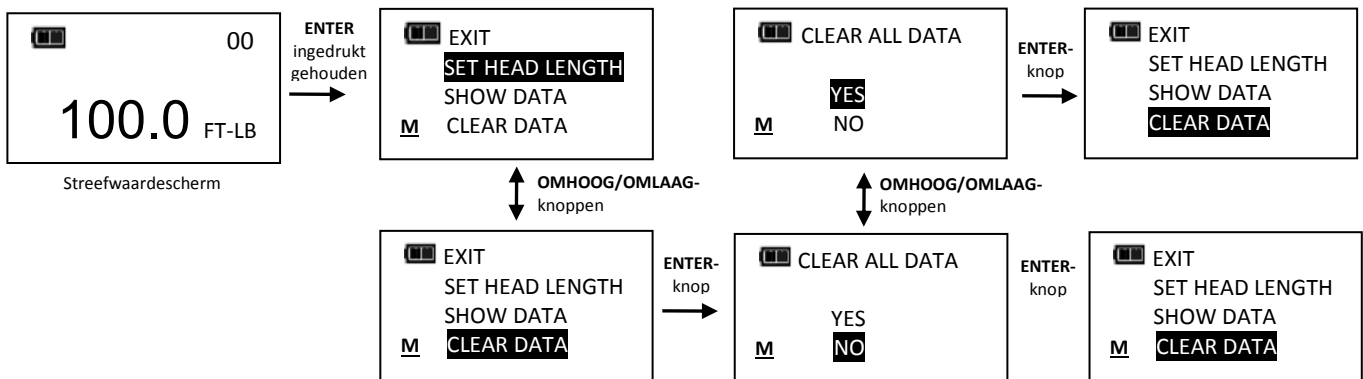

## Opgeslagen koppel- en hoekgegevens verwijderen

1. Druk vanuit het streefkoppel- of streefhoekscherf 3 seconden lang op de knop **ENTER** .
2. Markeer de menu-optie **CLEAR DATA** (gegevens wissen) met de knoppen **OMHOOG**  / **OMLAAG**  en druk vervolgens op de knop **ENTER**  om het scherm CLEAR ALL DATA (alle gegevens wissen) weer te geven.
3. Markeer in het menu CLEAR ALL DATA (alle gegevens wissen) de menu-optie **YES** om alle opgeslagen gegevens te verwijderen, of de menu-optie **NO** om af te sluiten zonder gegevens te verwijderen.
4. Druk op de knop **ENTER**  nadat u uw keuze hebt gemaakt.



## Het aantal sleutelcycli weergeven en wissen

Telkens als de streefwaarde voor het koppel of de hoek is bereikt, wordt de sleutelcyclustelling verhoogd. Het maximum aantal telbare cycli is 999999.

1. Druk vanuit het streefkoppel- of streefhoekscherf 3 seconden lang op de knop **ENTER** .
2. Markeer de menu-optie **CYCLE COUNT** (cyclustelling) door op de knoppen **OMHOOG**  / **OMLAAG**  te drukken.
3. Druk op de knop **ENTER**  om het scherm CYCLES (cycli) weer te geven.
4. Om het scherm CYCLE COUNT (cyclustelling) af te sluiten zonder de tellerwaarde te wissen, drukt u op de knop **ENTER**  terwijl de menu-optie **EXIT** gemarkeerd is.
5. Om de cyclusteller terug te zetten op 0 markeert u de menu-optie **CLEAR** en drukt u op de knop **ENTER** .
6. Na het wissen van de tellerwaarde wordt de menu-optie **EXIT** automatisch gemarkeerd. Druk op de knop **ENTER**  om terug te gaan naar het hoofdmenu.

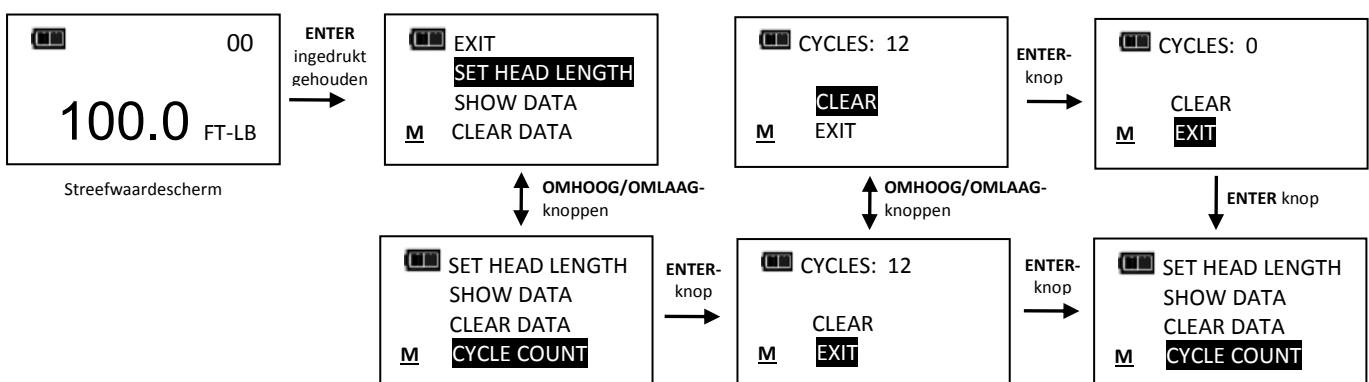

## Voorinstellingen voor streefwaarden (PSET)

Met de PSET-functie kunt u 10 streefwaarden voor het koppel of de hoek instellen, elke met een minimumwaarde (streefwaarde), maximumwaarde (buiten bereik) en batchtellingswaarde. De PSET (voorinstellingen) worden in het niet-vluchtige geheugen opgeslagen dus blijven bewaard als de sleutel is uitgeschakeld.

## Een voorinstelling voor koppel toevoegen

1. Selecteer in het streefkoppelscherm de maateenheid.
2. Houd de knop **EENHEDEN** **U** 3 seconden ingedrukt.
3. Het bevestigingsscherm ADD PRESET (Voorinstelling toevoegen) wordt weergegeven. Markeer de menu-optie **YES** met de knoppen **OMHOOG** **▲**/**OMLAAG** **▼** en druk vervolgens op de knop **ENTER** **↵**. Als u de menu-optie **NO** selecteert, keert u terug naar het hoofdmenu zonder een PSET toe te voegen.
4. **MINIMUM TORQUE** (minimumkoppel) is de streefwaarde waarbij de groene voortgangslampjes gaan branden, het geluidssignaal klinkt en de greep gaat trillen. De aanvankelijke **MINIMUM TORQUE**-waarde is de waarde van het streefkoppelscherm. **MINIMUM TORQUE** kan op elke waarde binnen het koppelbereik van de sleutel worden ingesteld met de knoppen **OMHOOG** **▲**/**OMLAAG** **▼**. Druk op de knop **ENTER** **↵** nadat u de gewenste waarde voor het streefkoppel hebt ingesteld.
5. Het scherm **MAXIMUM TORQUE** (maximumkoppel) wordt nu weergegeven. **MAXIMUM TORQUE** (maximumkoppel) is de streefwaarde waarboven het rode voortgangslampje gaat branden. De aanvankelijke waarde voor **MAXIMUM TORQUE** is **MINIMUM TORQUE** plus 4%. U kunt de waarde voor het maximale koppel hoger dan die voor **MINIMUM TORQUE** instellen, tot op 10% boven het maximale bereik van de sleutel, door op de knoppen **OMHOOG** **▲**/**OMLAAG** **▼** te drukken. Druk op de knop **ENTER** **↵** nadat u de gewenste waarde hebt ingesteld.
6. Het scherm **BATCH COUNT** (batchtelling) wordt nu weergegeven. De standaardwaarde is nul. Het bereik voor de batchtelling is 0 tot 99. Druk op de knoppen **OMHOOG** **▲**/**OMLAAG** **▼** om de batchwaarde te verhogen/verlagen. De modustelling neemt telkens toe wanneer het streefkoppel wordt bereikt als de batchtellingswaarde nul is ingevoerd. De modustelling neemt af als er een batchtelling wordt ingevoerd die niet nul is, en wordt teruggezet op de batchtellingswaarde wanneer de telling tot nul is gedaald. Druk op de knop **ENTER** **↵** nadat u de gewenste waarde hebt ingesteld.
7. Het scherm **PSET** (voorinstellingen) voor de streefwaarden wordt weergegeven, met vermelding van het volgende beschikbare **PSET**-nummer, van 01 tot 10.
8. Om nog meer koppelvoorinstellingen in te voeren, drukt u herhaaldelijk op de knop **ENTER** **↵** totdat het streefkoppelscherm wordt weergegeven, en herhaalt u de bovenstaande stappen.

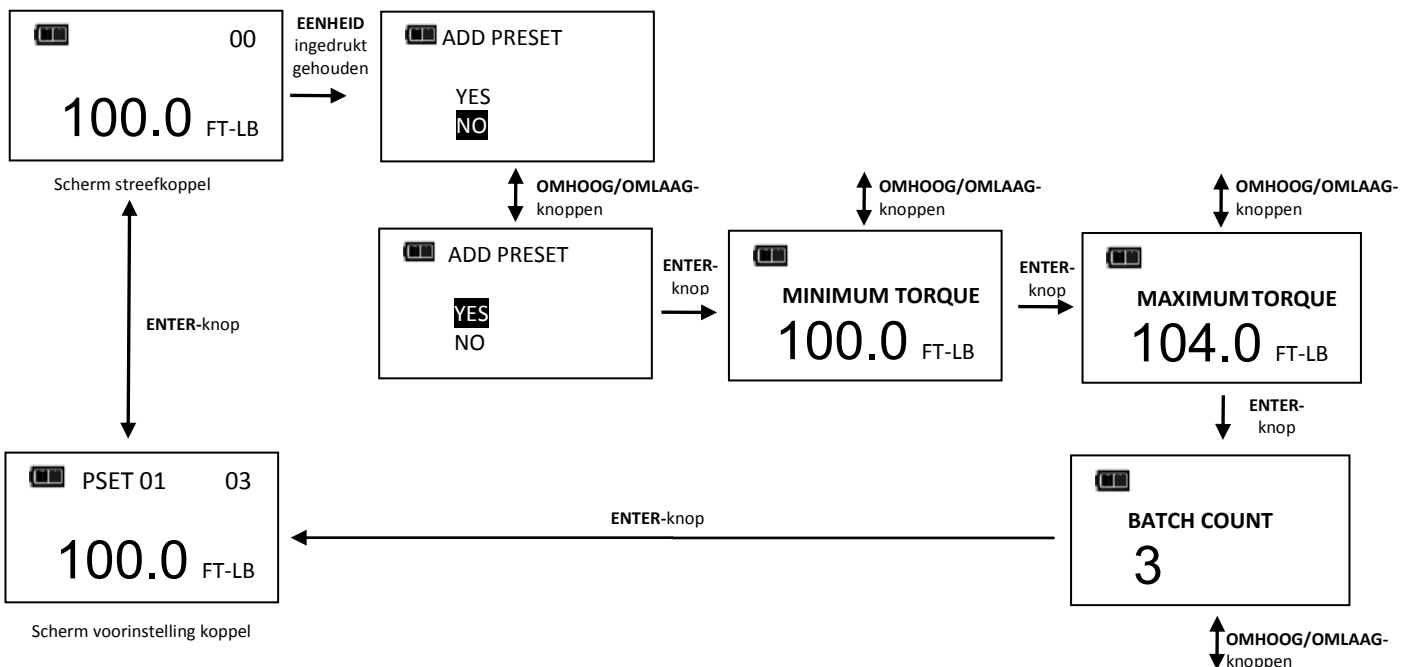

*Opm.: Om een opgeslagen voorinstelling of handmatig een streefkoppel- of -hoekmodus te selecteren, drukt u herhaaldelijk op de knop **ENTER** **↵** totdat de gewenste voorinstelling of de handmatige modus wordt weergegeven.*

## Een voorinstelling voor de hoek toevoegen

1. Houd vanuit het streefhoek scherm de knop **EENHEDEN** **U** 3 seconden ingedrukt.
2. Het bevestigingsscherm ADD PRESET (voorinstelling toevoegen) wordt weergegeven. Markeer de menu-optie **YES** met de knoppen **OMHOOG** **▲** / **OMLAAG** **▼** en druk vervolgens op de knop **ENTER** **↵**. Als u de menu-optie **NO** selecteert, keert u terug naar het hoofdmenu zonder een voorinstelling toe te voegen.
3. Het scherm MINIMUM ANGLE (minimumhoek) wordt weergegeven. MINIMUM ANGLE is de streefwaarde waarbij de gr te drukken. Druk op de knop oene voortgangslampjes gaan branden, het geluidssignaal klinkt en de greep gaat trillen. De aanvankelijke MINIMUM ANGLE-waarde is de waarde van het streefkoppelscherm. MINIMUM ANGLE kan op elke waarde van 0 tot 360° worden ingesteld door het indrukken van de knoppen **OMHOOG** **▲** / **OMLAAG** **▼**. Druk op de knop **ENTER** **↵** nadat u de gewenste waarde voor de streefhoek hebt ingesteld.
4. Het scherm MAXIMUM ANGLE (maximumhoek) wordt nu weergegeven. De MAXIMUM ANGLE (maximumhoek) is de hoekwaarde waarboven het rode voortgangslampje gaat branden. De aanvankelijke waarde voor MAXIMUM ANGLE is MINIMUM ANGLE plus 4%. U kunt de maximumhoek op een willekeurige waarde boven de MINIMUM ANGLE instellen door op de knoppen **OMHOOG** **▲** / **OMLAAG** **▼** te drukken. Druk op **ENTER** **↵** nadat u de gewenste waarde hebt ingesteld.
5. Het scherm BATCH COUNT (batchtelling) wordt nu weergegeven. De standaardwaarde is nul. Het bereik voor de batchtelling is 0 tot 99. Druk op de knoppen **OMHOOG** **▲** / **OMLAAG** **▼** om de batchwaarde te verhogen/verlagen. De modustelling neemt telkens toe wanneer de streefhoek wordt bereikt als de batchtellingswaarde nul is ingevoerd. De modustelling neemt af als er een batchtelling wordt ingevoerd die niet nul is, en wordt teruggezet op de batchtellingswaarde wanneer de telling tot nul is gedaald. Druk op de knop **ENTER** **↵** nadat u de gewenste waarde hebt ingesteld.
6. Het scherm PSET (voorinstellingen) voor de streefwaarden wordt weergegeven, met vermelding van het volgende beschikbare PSET-nummer, van 01 tot 10.
7. Om nog meer hoekvoorinstellingen in te voeren, drukt u herhaaldelijk op de knop **ENTER** **↵** totdat het streefhoek scherm wordt weergegeven, en herhaalt u de bovenstaande stappen.

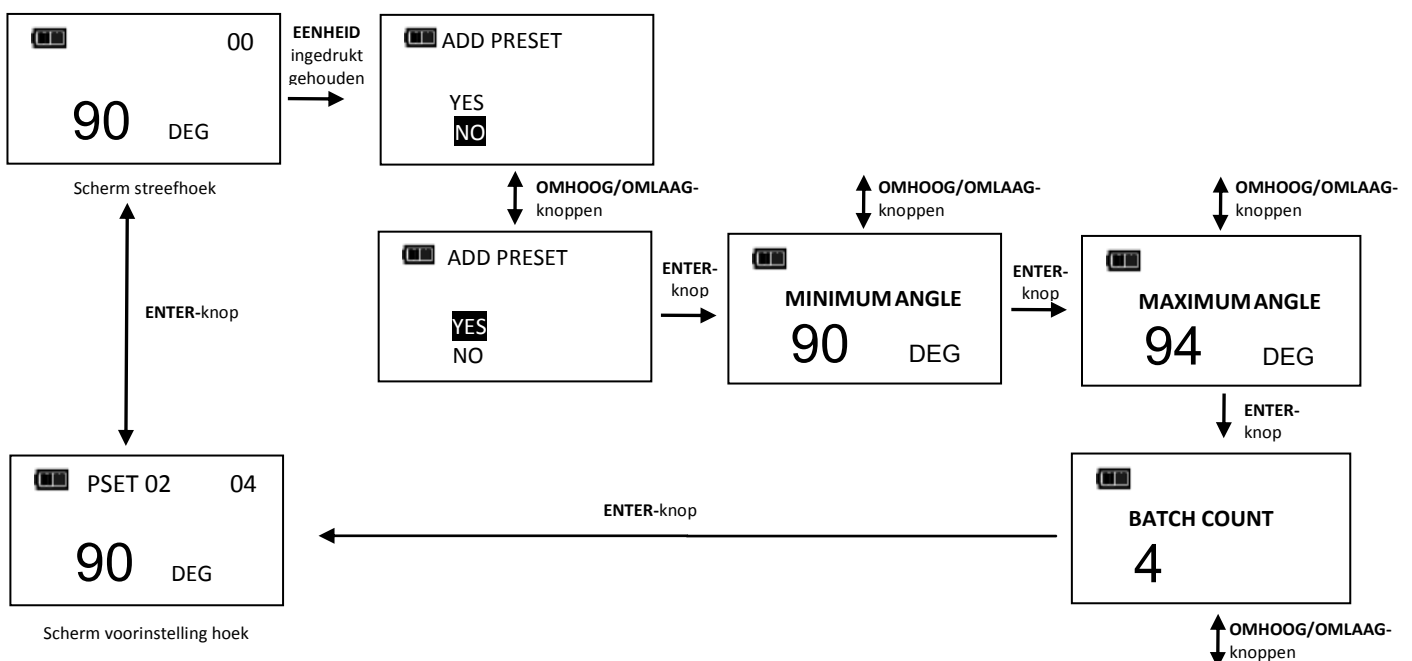

*Opm.: Om een opgeslagen voorinstelling of handmatig een streefkoppel- of -hoekmodus te selecteren, drukt u herhaaldelijk op de knop **ENTER** **↵** totdat de gewenste voorinstelling of de handmatige modus wordt weergegeven.*



## Voorinstellingen bewerken

Met de functie voor bewerking van voorinstellingen kunt de voorinstellingen bewerken die op de sleutel zijn opgeslagen.

1. Houd vanuit het te bewerken voorinstellings scherm de knop **EENHEDEN U** 3 seconden ingedrukt.
2. Het scherm CHANGE PRESET (voorinstelling wijzigen) wordt weergegeven.
3. Markeer de menu-optie **EDIT** met de knoppen **OMHOOG ▲**/**OMLAAG ▼** en druk vervolgens op de knop **ENTER ↵**.
4. Het scherm MINIMUM TORQUE (minimumkoppel) of MINIMUM ANGLE (minimumhoek) wordt weergegeven. U wijzigt de waarde met de knoppen **OMHOOG ▲**/**OMLAAG ▼**. Druk op de knop **ENTER ↵** nadat u de gewenste streefwaarde voor het koppel of de hoek hebt ingesteld.
5. Het scherm MAXIMUM TORQUE (maximumkoppel) of MAXIMUM ANGLE (maximumhoek) wordt weergegeven. U wijzigt de waarde met de knoppen **OMHOOG ▲**/**OMLAAG ▼**. Druk nadat u de gewenste streefwaarde voor het koppel of de hoek hebt ingesteld op de knop **ENTER ↵**.
6. Het scherm BATCH COUNT (batchtelling) wordt nu weergegeven. U wijzigt de waarde met de knoppen **OMHOOG ▲**/**OMLAAG ▼**. Druk op de knop **ENTER ↵** nadat u de gewenste batchtellingswaarde hebt ingesteld.
7. Het scherm met de streefwaarde voor PSET (voorinstellingen) wordt weergegeven, met vermelding van hetzelfde PSET-nummer.

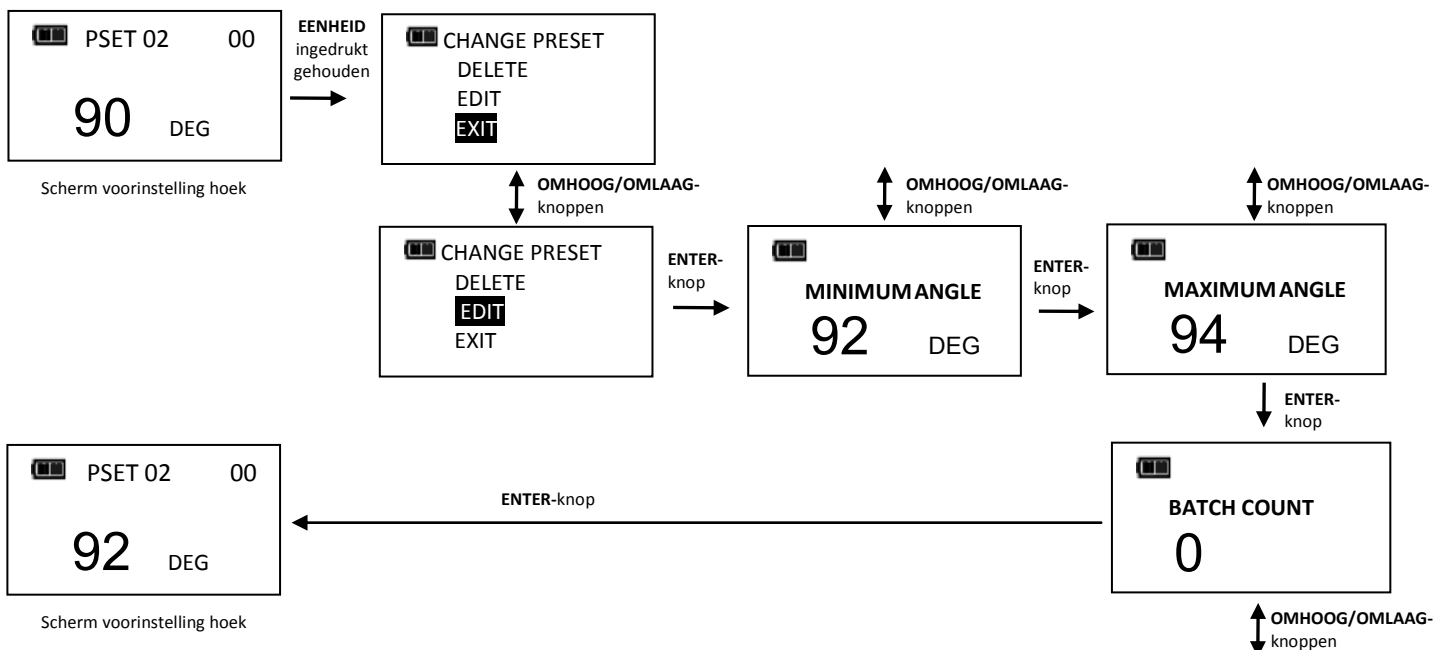



*Opm.: Als u de knop **ENTER ↵** indrukt terwijl de menu-optie **EXIT** is gemarkeerd, sluit u het menu af zonder de voorinstelling te bewerken.*

## Voorinstellingen deleten

Met de functie voor het verwijderen van voorinstellingen kunt u opgeslagen voorinstellingen van de sleutel deleten.

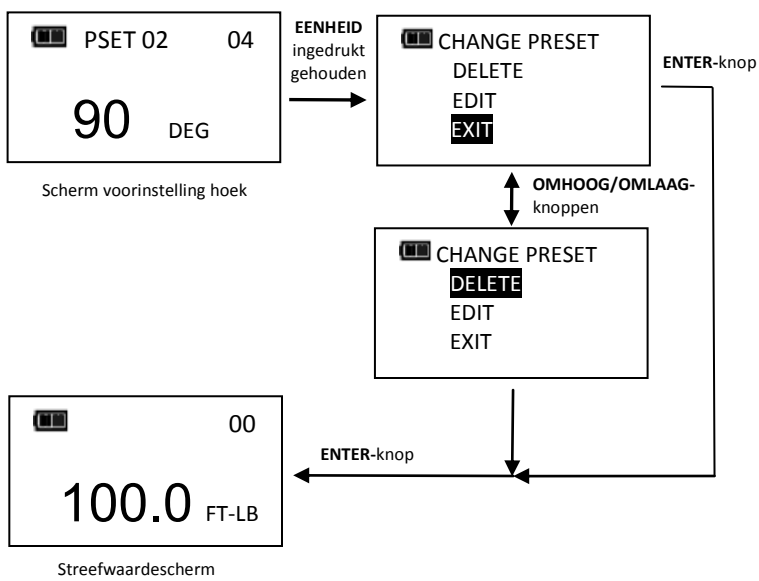
1. Houd op het scherm met de te deleten voorinstelling de knop **EENHEDEN U** 3 seconden ingedrukt.
2. Het scherm CHANGE PRESET (voorinstelling wijzigen) wordt weergegeven.
3. Markeer de menu-optie **DELETE** met de knoppen **OMHOOG ▲**/**OMLAAG ▼** en druk vervolgens op de knop **ENTER ↵**.
4. Het streefwaardescherf wordt weergegeven, en de gedelete voorinstelling is niet meer beschikbaar.







*Opm.: Als u de knop **ENTER**  indrukt terwijl de menu-optie **EXIT** is gemarkeerd, sluit u het menu af zonder de voorinstelling te deleten.*

*Opm.: Bij het deleten van een PSET behouden alle andere opgeslagen voorinstellingen hun oorspronkelijke PSET-nummer. Als er een nieuwe PSET wordt ingevoerd, krijgt die het eerstvolgende PSET-nummer dat beschikbaar is.*



## • Geavanceerde instellingen

### Geavanceerde instellingen openen

U bereikt de geavanceerde instellingen via de menu-optie **SETTINGS** in het hoofdmenu.

1. Druk vanuit het streefkoppel- of streefhoekscherf 3 seconden op de knop **ENTER** .
2. Markeer de menu-optie **SETTINGS** door op de knoppen **OMHOOG** /**OMLAAG**  te drukken.
3. Druk op de knop **ENTER**  om het instellingsmenu weer te geven.

Menu-opties:

- **EXIT** (afsluiten) – Sluit het instellingsmenu af; het streefwaardescherm wordt weergegeven.
  - **SHOW INFO** (info weergeven) – Geeft informatie over de werking van de sleutel weer.
  - **SLEEP TIME** (slaaptijdstip) – Opent het scherm waarop wordt ingesteld wanneer de sleutel automatisch wordt uitgeschakeld.
  - **LCD CONTRAST** (contrast lcd) – Opent het scherm waarop het displaycontrast wordt ingesteld.
  - **KEY BEEP** (toetstoon) – Opent het scherm waarop de toetstoon in- of uitgeschakeld kan worden.
  - **AUTO BACKLIGHT** (automatische schermverlichting) – Opent het scherm waarin de schermverlichting tijdens het meten in- of uitgeschakeld kan worden.
  - **TOGGLE BACKLIGHT** (flipflop verlichting) – Opent het scherm voor het in-/uitschakelen van de time-out of flipflopfunctie van de knop **VERLICHTING** .
  - **VIBRATOR CONFIG** (vibratorinstelling) – Opent het scherm voor het in- of uitschakelen van de vibrator bij bereik van de streefwaarde.
4. Om het instellingsmenu af te sluiten en terug te gaan naar het streefkoppel- of hoekscherf, drukt u op de knop **ENTER**  terwijl de menu-optie **EXIT** gemarkeerd is.

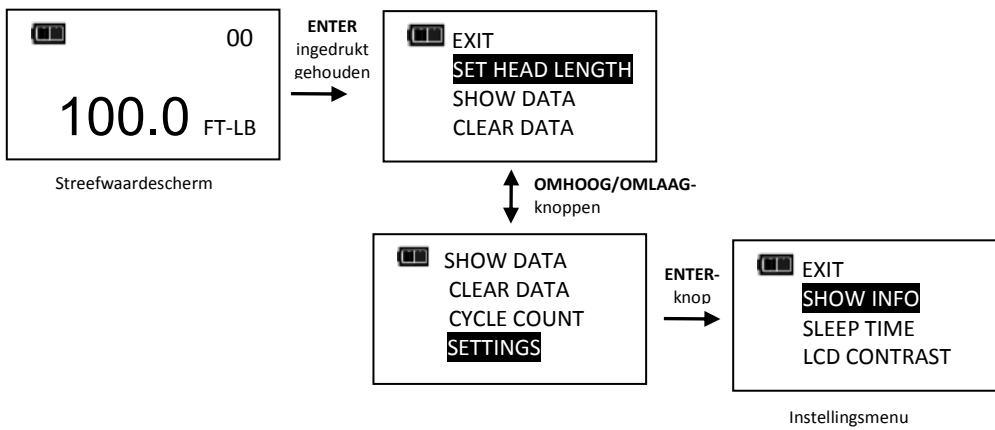

*Opm.: Alle door de gebruiker configureerbare instellingen worden in het niet-vluchtige geheugen opgeslagen en blijven behouden als de sleutel wordt uitgeschakeld.*

### Show Info (info weergeven)

De menu-optie SHOW INFO geeft informatie over de werking van de sleutel weer.

1. Druk vanuit het instellingsmenu op de knop **ENTER** terwijl de menu-optie **SHOW INFO** gemarkeerd is.
2. Het scherm SHOW INFO (info weergegeven) wordt weergegeven.
3. Met de knoppen **OMHOOG** /**OMLAAG** schuift u door het scherm.

Gebruiksgegevens:

- CAL: Datum van laatste kalibratie sleutel.
  - ISD: Datum waarop met gebruik van sleutel is begonnen.
  - TCF: Torque Calibration Factor, koppelkalibratiefactor.
  - ACF: Angle Calibration Factor, hoekkalibratiefactor.
  - VER: Softwareversie.
  - OVR CNT: Overkoppeltelling houdt bij hoe vaak de sleutel te ver is aangetrokken (koppel > 125% van volledige schaal).
  - TQZ: Torque Zero Offset, nuloffset koppel.
  - ANZ: Angle Zero Offset, nuloffset hoek.
4. Als u op de knop **ENTER** drukt, wordt het scherm Show Info afgesloten en het instellingsmenu weer weergegeven.

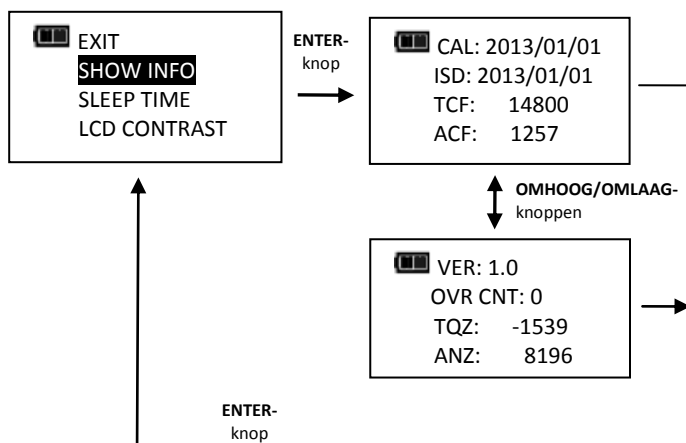

### Slaaptijd instellen

Met deze functie stelt u in wanneer de sleutel automatisch wordt uitgezet na het laatste koppel of de laatste druk op de knop.

1. Gebruik de knoppen **OMHOOG** /**OMLAAG** vanuit het instellingsmenu om de menu-optie **SLEEP TIME** te markeren en druk dan op de knop **ENTER** .
2. Het scherm SLEEP TIME (slaaptijdstip) wordt weergegeven.
3. Gebruik de knoppen **OMHOOG** /**OMLAAG** om het slaapinterval in te stellen.

Selecteerbare intervallen:



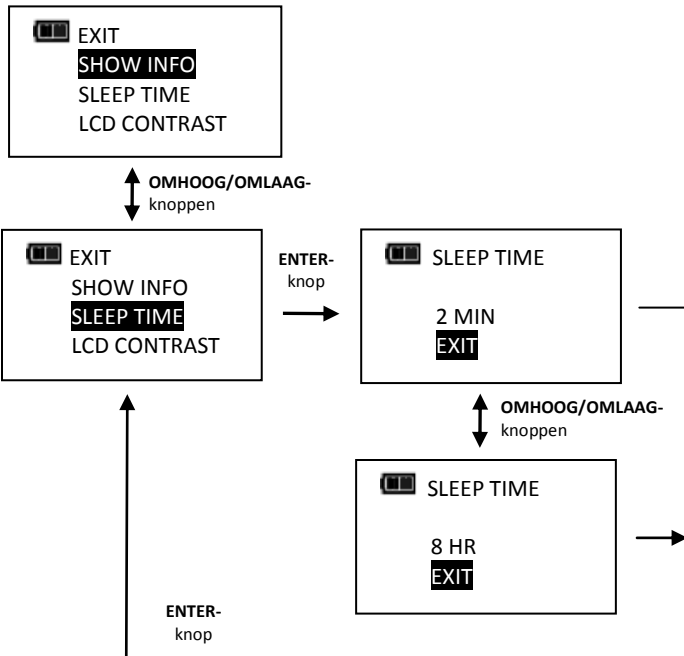

- 2 MIN (standaardinstelling)
- 5 MIN
- 10 MIN
- 30 MIN
- 1 HR
- 2 HR
- 8 HR

4. Druk op de knop **ENTER**  om de keuze te bevestigen en terug te gaan naar het instellingsmenu.



### Lcd-contrast instellen

Met deze functie kunt u het contrast van de display voor optimale leesbaarheid instellen.

1. Gebruik vanuit het instellingsmenu de knoppen **OMHOOG**  / **OMLAAG**  om de optie **LCD CONTRAST** te markeren en druk dan op de knop **ENTER** .
2. Het scherm CONTRAST wordt weergegeven.
3. Gebruik in dit scherm de knoppen **OMHOOG**  / **OMLAAG**  om het contrast op de gewenste waarde in te stellen.

Selecteerbare niveaus: 20 tot 80 in stappen van 5 (standaardinstelling = 40).

4. Druk op de knop **ENTER**  om de keuze te bevestigen en terug te gaan naar het instellingsmenu.

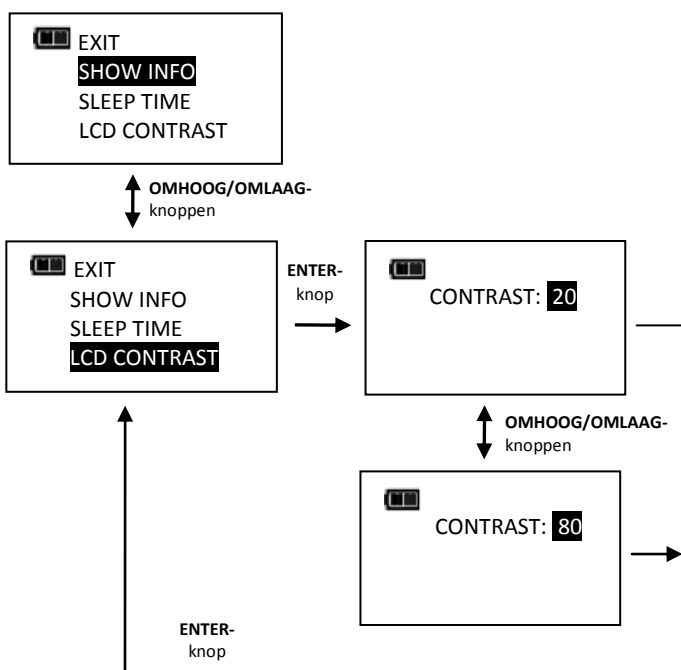

## Toetstoon instellen

Met deze functie kunt u het geluidssignaal bij het indrukken van de knoppen in- of uitschakelen.

1. Gebruik de knoppen **OMHOOG ▲**/**OMLAAG ▼** vanuit het instellingsmenu om de menu-optie **KEY BEEP** (toetstoon) te markeren en druk dan op de knop **ENTER ↵**.
2. Het scherm KEY BEEP (toetstoon) wordt weergegeven.
3. Gebruik de knoppen **OMHOOG ▲**/**OMLAAG ▼** om ENABLE (inschakelen; standaard) of DISABLE (uitschakelen) te selecteren.
4. Druk op de knop **ENTER ↵** om de keuze te bevestigen en terug te gaan naar het instellingsmenu.

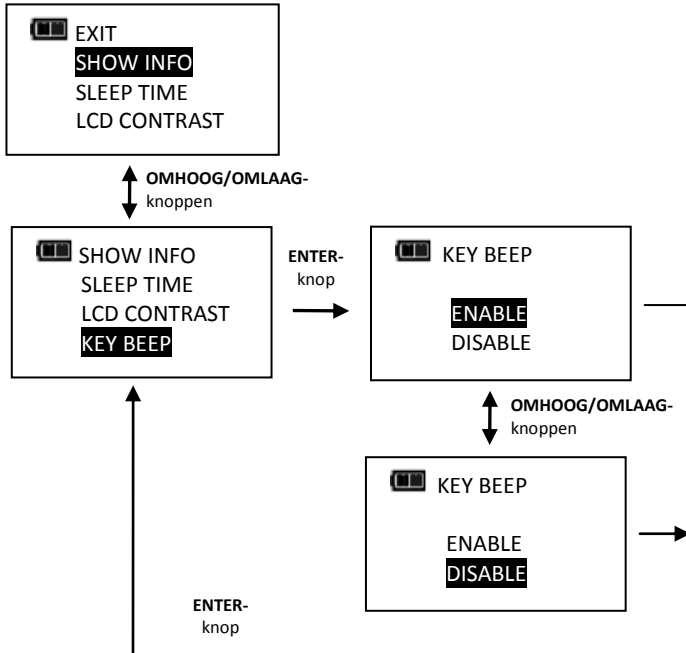

## Flipflop schermverlichting instellen

Met deze functie kunt u de flipflopfunctie van de schermverlichting in- of uitschakelen. Als de flipflopmodus is uitgeschakeld, wordt de schermverlichting met de knop **VERLICHTING 📡** ingeschakeld, en gaat hij vijf seconden na de laatste knopdruk automatisch uit. Als de flipflopmodus is ingeschakeld, wordt de schermverlichting met de knop **VERLICHTING 📡** ingeschakeld, en blijft hij aan totdat u opnieuw op de knop **VERLICHTING 📡** drukt.

1. Gebruik de knoppen **OMHOOG ▲**/**OMLAAG ▼** vanuit het instellingsmenu om de menu-optie **TOGGLE BACKLGT** te markeren en druk dan op de knop **ENTER ↵**.
2. Het scherm TOGGLE BACKLIGHT (flipflop schermverlichting) wordt weergegeven.
3. Gebruik de knoppen **OMHOOG ▲**/**OMLAAG ▼** om ENABLE (inschakelen) of DISABLE (uitschakelen; standaard) te selecteren.
4. Druk op de knop **ENTER ↵** om de keuze te bevestigen en terug te gaan naar het instellingsmenu.

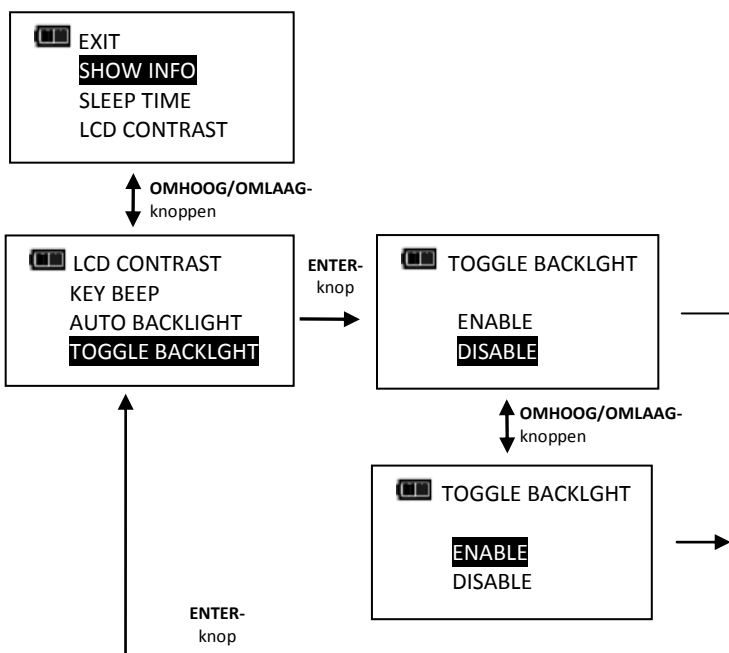







Opm.: De schermverlichting gaat altijd uit als u op de knop **STROOM**  drukt of de slaaptijd is ingegaan.

Opm.: Als de flipflopfunctie voor de schermverlichting is ingeschakeld en de schermverlichting aan is, blijft het scherm tijdens en na het uitoefenen van koppel verlicht.

## Vibratorconfiguratie

Met deze functie kunt u de vibrator bij het bereiken van de streefwaarde Aan of Uit zetten, zowel naar wens als om de batterijen te sparen.



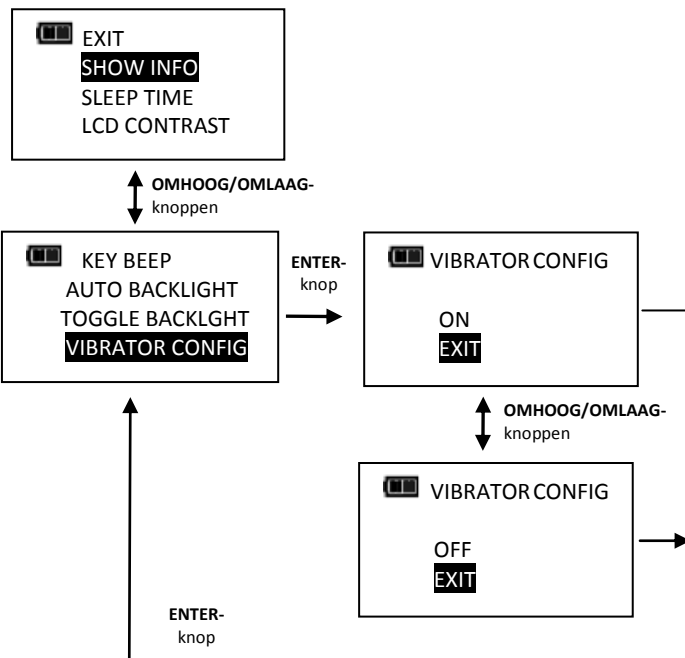

1. Gebruik de knoppen **OMHOOG**  / **OMLAAG**  vanuit het instellingsmenu om de menu-optie **VIBRATOR CONFIG** te configureren, en druk dan op de knop **ENTER** .
2. Het scherm VIBRATOR CONFIG (vibratorconfiguratie) wordt weergegeven.
3. Gebruik de knoppen **OMHOOG**  / **OMLAAG**  om ON (aan) of OFF (uit) te selecteren.
4. Druk op de knop **ENTER**  om de keuze te bevestigen en terug te gaan naar het instellingsmenu.



## • Geavanceerde configuratie

### Geavanceerde configuratie openen

U bereikt de geavanceerde instellingen via de menu-optie **CONFIGURE** in het hoofdmenu.

1. Druk vanuit het streefkoppel- of streefhoekscherf 3 seconden op de knop **ENTER** .
2. Markeer de menu-optie **CONFIGURE** met de knoppen **OMHOOG**  / **OMLAAG** .
3. Druk op de knop **ENTER**  om het configuratiemenu weer te geven.

Menu-opties:

- EXIT (afsluiten) – Sluit het configuratiemenu af; het streefwaardescherf voor hoek of koppel wordt weergegeven.
  - MODE SETUP (modusinstelling) – Opent het menu voor instelling van de sleutelmodi.
  - CALIBRATION (kalibratie) – Opent het menu voor sleutelkalibratie (met wachtwoordbeveiliging).
  - SET DATE/TIME (datum/tijd instellen) – Opent de schermen voor het invoeren van de klokdatum en tijd.
  - SET CAL INTRVAL (kalibratie-interval instellen) – Opent het scherm voor instelling van het kalibratie-interval (hiervoor moeten de klokdatum en tijd ingesteld zijn).
4. Om het configuratiemenu af te sluiten en terug te gaan naar het streefwaardescherf of streefhoekscherf, drukt u op de knop **ENTER**  terwijl de menu-optie **EXIT** is gemarkeerd.

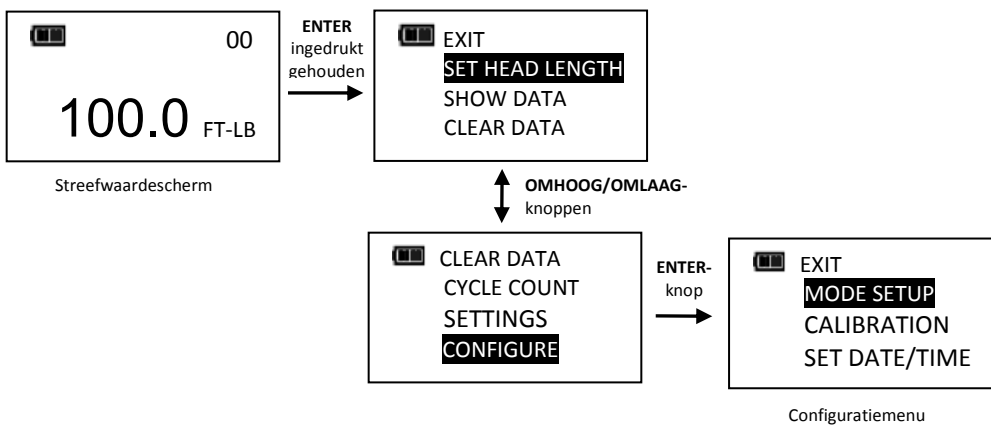

*Opm.: Alle door de gebruiker configureerbare instellingen worden in het niet-vluchtige geheugen opgeslagen en blijven behouden als de sleutel wordt uitgeschakeld.*

### Mode Setup (modusinstelling)

In het modusinstellingsmenu kunt u de modus 'Koppel EN DAN hoek' in- of uitschakelen.

1. Druk vanuit het configuratiemenu op de knop **ENTER** terwijl de menu-optie **MODE SETUP** is gemarkeerd.
2. Het menu voor de modusinstelling wordt weergegeven.

Menu-opties:

- EXIT (afsluiten) – Sluit het menu voor modusinstelling af; het configuratiescherf wordt weergegeven.
  - THEN DISABLED (EN DAN uitgeschakeld) – Opent het scherm voor het in- of uitschakelen van de EN DAN-modus.
3. Gebruik de knoppen **OMHOOG** /**OMLAAG** om de menu-opties te markeren.
  4. Druk op **ENTER** terwijl de menu-optie **EXIT** wordt weergegeven om terug te gaan naar het configuratiemenu.

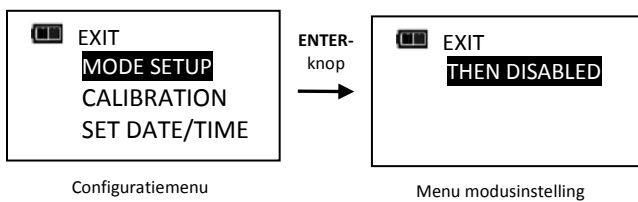

### Modus 'Koppel EN DAN hoek' in- of uitschakelen

Met deze functie kunt u de modus 'Koppel EN DAN' in- of uitschakelen.

1. Gebruik in het menu voor modusinstelling de knoppen **OMHOOG** /**OMLAAG** om de optie **THEN DISABLED** (en dan uitgeschakeld; standaardinstelling) te markeren en druk dan op de knop **ENTER** .
2. Het scherm voor in-/uitschakelen van TQ THEN ANGLE (koppel en dan hoek) wordt weergegeven.
3. Gebruik de knoppen **OMHOOG** /**OMLAAG** om ENABLE (inschakelen) of DISABLE (uitschakelen) te selecteren.
4. Druk op de knop **ENTER** om de keuze te bevestigen en terug te gaan naar het menu voor modusinstelling.

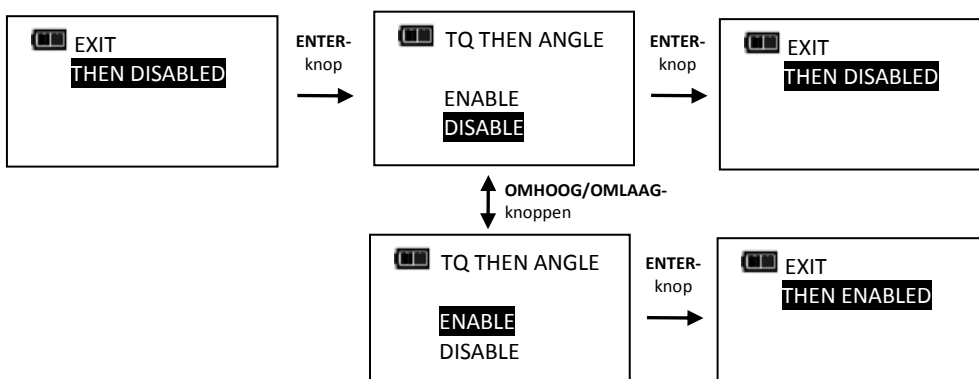

*Opm.: Het gemarkeerde menu-item geeft de configuratie op dat moment aan: ENABLED (ingeschakeld) of DISABLED (uitgeschakeld).*

## Modus koppel EN DAN hoek

U stelt de modus 'Koppel EN DAN hoek' in door eerst een streefkoppel met maateenheid in te stellen en vervolgens een streefhoek in te stellen voordat u de modus 'Koppel EN DAN hoek' selecteert. Als het uitgeoefende koppel in de modus 'Koppel EN DAN hoek' de streefwaarde heeft bereikt, schakelt de sleutel automatisch over op de hoekmodus om de hoek te meten. De voortgangslampjes geven de vordering bij het uitoefenen van koppel aan terwijl het koppel wordt gemeten, en vervolgens de vordering voor de hoek wanneer de hoek wordt gemeten.

1. Gebruik in het streefkoppelscherm de knoppen **OMHOOG** ▲/**OMLAAG** ▼ om het streefkoppel in te stellen en dan de knop **EENHEDEN** U om de maateenheid voor het koppel in te stellen, en druk dan op de knop **ENTER** ↵.
2. Het streefhoekscherm wordt nu weergegeven. Gebruik de knoppen **OMHOOG** ▲/**OMLAAG** ▼ om de streefhoek in te stellen en druk dan op de knop **ENTER** ↵.
3. Het scherm voor de modus 'Koppel EN DAN hoek' wordt weergegeven.
4. Oefen koppel uit totdat de streefwaarde wordt bereikt en draai de sleutel vervolgens naar de streefhoek.

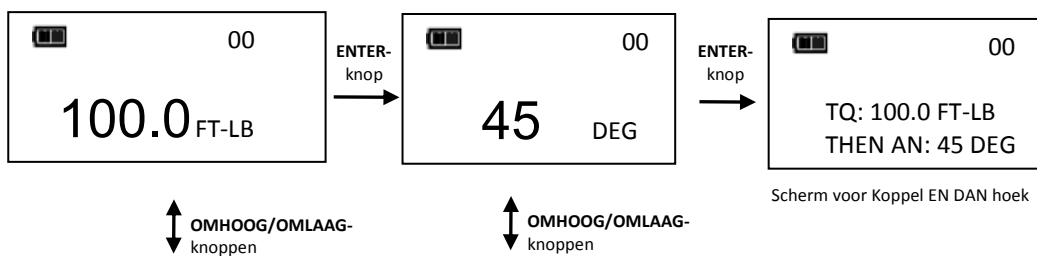

*Opm.: U kunt de knop **EENHEDEN** U gebruiken om de maateenheid voor het koppel te selecteren in het scherm 'Koppel EN DAN hoek'.*

*Opm.: U stelt de voorinstellingen voor 'Koppel EN DAN hoek' in door de knop Eenheden ingedrukt te houden in het scherm 'Koppel EN DAN hoek'. Zie 'Een voorinstelling voor koppel toevoegen' en 'Een voorinstelling voor de hoek toevoegen' in het basisgedeelte voor het invoeren van parameters.*

*Opm.: De koppelcyclus wordt alleen in het geheugen opgeslagen als zowel het streefkoppel als de streefhoek worden gehaald.*

*Opm.: In de handmatige modus gaan de gele en rode voortgangslampjes branden als het koppel meer dan 110% van de volle schaal van de sleutel bereikt of als de hoek meer dan 4% groter is dan de streefwaarde.*

*Opm.: In de voorinstellingsmodus gaan de gele en rode voortgangslampjes branden als het koppel het maximumkoppel overschrijdt of de hoek de maximumhoek overschrijdt.*

## Kalibratie

Het kalibratiemenu wordt met een wachtwoord beschermd. Neem voor informatie over het kalibratiemenu contact op met uw plaatselijke Snap-on reparatiecentrum.

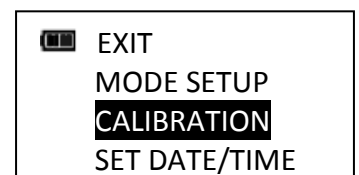

## Datum en tijd instellen

Met de functie Set Date/Time (datum en tijd instellen) kunt u de datum en tijd voor de real time-klok instellen voor een tijdstempel voor gegevensrecords, registratie van de laatste kalibratiedatum en waarschuwingen bij het verstrijken van een kalibratie-interval.

*Opm.: Als de datum en tijd voor het eerst worden ingesteld, wordt ook de datum voor In-Service (ingebruikstelling) ingesteld. Deze wordt gebruikt voor het berekenen van het eerste kalibratie-interval (Zie 'Kalibratie-interval instellen' in het onderdeel 'Geavanceerde configuratie').*



1. Gebruik de knoppen **OMHOOG ▲**/**OMLAAG ▼** vanuit het instellingsmenu om de menu-optie **SET DATE/TIME** te markeren en druk dan op de knop **ENTER ↵**.
2. Het scherm SET DATE (datum instellen) wordt geopend, met het jaar gemarkeerd.
3. Gebruik de knoppen **OMHOOG ▲**/**OMLAAG ▼** om het jaar in te stellen en druk dan op de knop **ENTER ↵**.
4. Gebruik de **OMHOOG ▲**/**OMLAAG ▼** knoppen om de maand in te stellen en druk dan op de knop **ENTER ↵**.
5. Gebruik de knoppen **OMHOOG ▲**/**OMLAAG ▼** om de dag in te stellen en druk dan op de knop **ENTER ↵**.
6. Het scherm SET TIME (tijd instellen) wordt weergegeven, met de optie HR (uur) gemarkeerd.
7. Gebruik de knoppen **OMHOOG ▲**/**OMLAAG ▼** om het uur in te stellen en druk dan op de knop **ENTER ↵** om de minuten te markeren.
8. Gebruik de knoppen **OMHOOG ▲**/**OMLAAG ▼** om de minuten in te stellen en druk dan op de knop **ENTER ↵** om de seconden te markeren.
9. Gebruik de knoppen **OMHOOG ▲**/**OMLAAG ▼** om de seconden in te stellen, en druk dan op de knop **ENTER ↵**.
10. De klok is nu ingesteld, en het configuratiemenu wordt weergegeven.

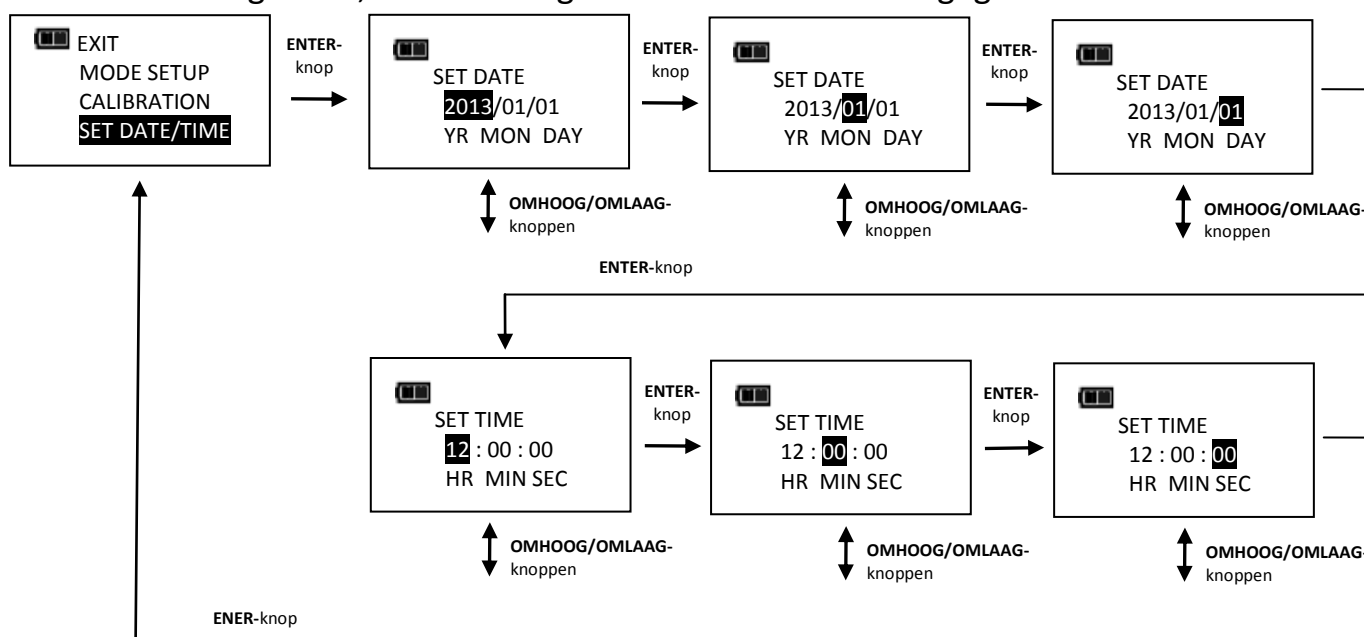

*Opm.: Het jaar kan op 2013 of hoger worden ingesteld. Voor de maand kunt u 1 t/m 12 doorlopen. Voor de dag kunt u 1 t/m 31 doorlopen.*

*Opm.: Voor het uur kunt u 0 t/m 23 doorlopen. Voor de minuten en seconden kunt u 0 t/m 59 doorlopen.*

*Opm.: Als de batterijen 20 minuten of langer uit de sleutel worden verwijderd, komt de klok weer op de standaardinstellingen te staan en moet hij na het aanzetten opnieuw worden ingesteld.*

### **Kalibratie-interval instellen**

Met deze functie kunt u het interval instellen waarna het bericht 'CAL NEEDED' (kalibratie vereist) wordt weergegeven.

1. Gebruik in het instellingsmenu de knoppen **OMHOOG ▲**/**OMLAAG ▼** om de optie **SET CAL INTERVAL** te markeren, en druk dan op de knop **ENTER ↵**.
2. Het scherm CAL INTERVAL (kalibratie-interval) wordt weergegeven.
3. Gebruik de knoppen **OMHOOG ▲**/**OMLAAG ▼** om het kalibratie-interval te wijzigen.

Selecteerbare intervallen:

- DISABLED (uitgeschakeld; standaardinstelling)
- 3 MON (3 maanden)
- 6 MON (6 maanden)
- 12 MON (12 maanden)

4. Druk op de knop **ENTER**  om de selectie te bevestigen, het scherm af te sluiten en terug te gaan naar het instellingsmenu.

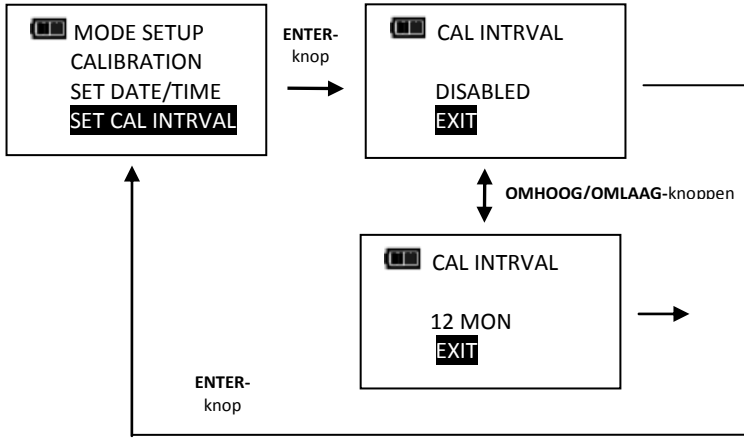

*Opm.: De datum en tijd voor de klok moeten ingesteld zijn om het kalibratie-interval te kunnen gebruiken. Als de batterijen 20 minuten of langer uit de sleutel worden verwijderd, komt de klok weer op de standaardinstellingen te staan en moet hij na het aanzetten opnieuw worden ingesteld.*











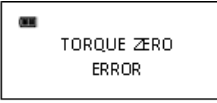
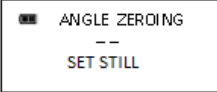

*Opm.: Het kalibratie-interval wordt berekend vanaf de datum van ingebruikstelling (In-Service Date) of vanaf de laatste kalibratiedatum (zie menu SHOW INFO [info weergeven]), afhankelijk van wat de laatste datum is. Als de klok een datum na de datum van ingebruikstelling of de laatste kalibratiedatum plus het kalibratie-interval heeft bereikt, wordt het bericht 'CAL NEEDED' (kalibratie vereist) weergegeven als de sleutel wordt aangezet of als er een nulinstelling is verricht. Druk op de knop **ENTER**  om door te gaan naar het streefwaardemenu. Als u koppel uitoefent terwijl het bericht 'CAL NEEDED' (kalibratie vereist) wordt weergegeven, wordt het gemeten koppel of de gemeten hoek direct weergegeven, en gaat u terug naar het streefwaardemenu nadat u het koppel hebt opgeheven.*

*Opm.: Als alternatief voor het kalibratie-interval bevat het kalibratiemenu tevens een Calibration Cycle Counter (kalibratiecyclusteller) (neem contact op met uw plaatselijke Snap-on reparatiecentrum over het kalibratiemenu).*

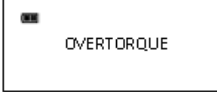
## • Probleemoplossing

*Opm.: Breng de sleutel terug naar een erkend Snap-on reparatiecentrum als een of meer van de onderstaande problemen aanhouden.*

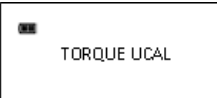
Probleem	Mogelijke oorzaak	Oplossing
Sleutel gaat niet aan als u op knop <b>STROOM</b>  drukt	Batterijen leeg/ontbreken	Vervang de batterijen
	Softwareprobleem	Schakel stroom uit en weer in met de einddop
Koppelwaarde buiten specificaties	Kalibratie vereist	Verricht een kalibratie
	Verkeerde koplengte ingevoerd	Voer de juiste offset-lengte voor de kop in
Sleutel heeft instellingen niet onthouden na verwijderen batterijen	Batterijen verwijderd voordat instellingen in niet-vluchtig geheugen waren opgeslagen.	Voer de instellingen weer in en houd de knop <b>STROOM</b>  ingedrukt om de sleutel uit te zetten voordat u de batterijen verwijdert
Koppel of hoek wordt weergegeven terwijl er geen koppel wordt uitgeoefend	Koppel of hoek op nul ingesteld terwijl er koppel werd uitgeoefend	Leg de sleutel op een stabiel oppervlak zonder koppel uit te oefenen en druk op de knop <b>STROOM</b>  om een nulinstelling te verrichten
	Batterij bijna leeg	Press <b>ENTER</b>  button to continue using wrench and replace batteries soon

Probleem	Mogelijke oorzaak	Oplossing
	Batterij leeg	Press <b>STROOM</b>  button to turn off wrench and replace batteries
	Koppel uitgeoefend tijdens nulinstelling	Haal de sleutel los en verricht opnieuw een nulinstelling
	Sleutel voorbij koppel aangehaald	Verricht een kalibratie
	Sleutel verkeerd gekalibreerd	Verricht een kalibratie
	Koppelsensor defect	Terugsturen naar een Snap-on reparatiecentrum
	Sleutel bewogen tijdens nulinstelling	Leg de sleutel op een stabiele ondergrond
	Gyroscoop niet stabiel	Terugsturen naar een Snap-on reparatiecentrum
	<b>STROOM</b>  ingedrukt tijdens nulinstelling hoek (nulinstelling onderbroken om menu's te openen)	Leg de sleutel op een stabiel oppervlak en druk op de knop <b>STROOM</b>  om een nulinstelling te verrichten
	Meer dan 125% van volle schaal koppel uitgeoefend	Zet de sleutel uit en weer aan met de knop <b>STROOM</b>  en verricht een kalibratie
	Sleutel te snel gedraaid tijdens hoekmeting	Leg de sleutel op een stabiel oppervlak en druk op de knop <b>STROOM</b>  om een nulinstelling te verrichten
	Geheugenstoring	Wis het gegevensgeheugen
	Koppel niet gekalibreerd	Kalibreer het koppel
	Hoek niet gekalibreerd	Kalibreer de hoek

## • GEBRUIK VAN VERLOOPSTUKKEN, VERLENGSTUKKEN EN UNIVERSELE HULPSTUKKEN

Telkens als u een verloopstuk, verlengstuk of universeel hulpstuk gebruikt met een momentsleutel en de afstand tot de bevestiging verschilt van die van het vierkant van de momentsleutel ten tijde van de kalibratie, moet de koplengte worden aangepast om een juiste koppelwaarde te kunnen meten.

Bij gebruik van een scharnierend verlengstuk of universeel hulpstuk mag de hoek ten opzichte van het vierkant niet meer dan 15 graden zijn. Gebruik geen lange verlengstukken met de flex-drive helemaal geknikt.

## • KALIBRATIE

Neem voor kalibratieservice contact op met de vertegenwoordiger van Snap-on.

## ● CERTIFICERING

Deze TechAngle<sup>®</sup>-sleutel is in de fabriek gekalibreerd met hoekverplaatsing en koppelmeetinstrumenten conform de bepalingen van het National Institute of Standards and Technology (N.I.S.T.). De koppelparameters voldoen aan de eisen van ISO 6789-2003 en ASME B107-28-2010. Opm.: Er bestaan geen Amerikaanse of buitenlandse normen voor scharniersleutels.

<p><b>BELANGRIJK!</b> De kalibratievoorvallen worden in het geheugen van de sleutel opgeslagen en vormen bewijs voor nietigverklaring van de fabriekskalibratie.</p>
--

## ● ONDERHOUD/REPARATIES

Maak de sleutel schoon door hem met een vochtige doek af te nemen. GEEN oplosmiddel, thinner of carburateurreiniger gebruiken.

NOOIT in vloeistoffen onderdompelen.

Onderhoud, reparaties en kalibratie mogen uitsluitend bij een Snap-on Service Center worden verricht. Neem hiervoor contact op met de vertegenwoordiger van Snap-on Tools .

Reparaties van de ratelkop kunnen zowel door de vertegenwoordiger van Snap-on als door de gebruiker worden verricht.

## • Batterijen vervangen

### Uitsluitend vervangen door drie AA-batterijen.

- Probeer niet om de alkaliceelbatterijen op te laden.
- Gebruik nooit verschillende soorten batterijen door elkaar.
- Vervang alle batterijen tegelijkertijd.
- Bewaar de sleutel op een droge plaats.
- Verwijder de batterijen als u de sleutel langer dan 3 maanden opbergt.

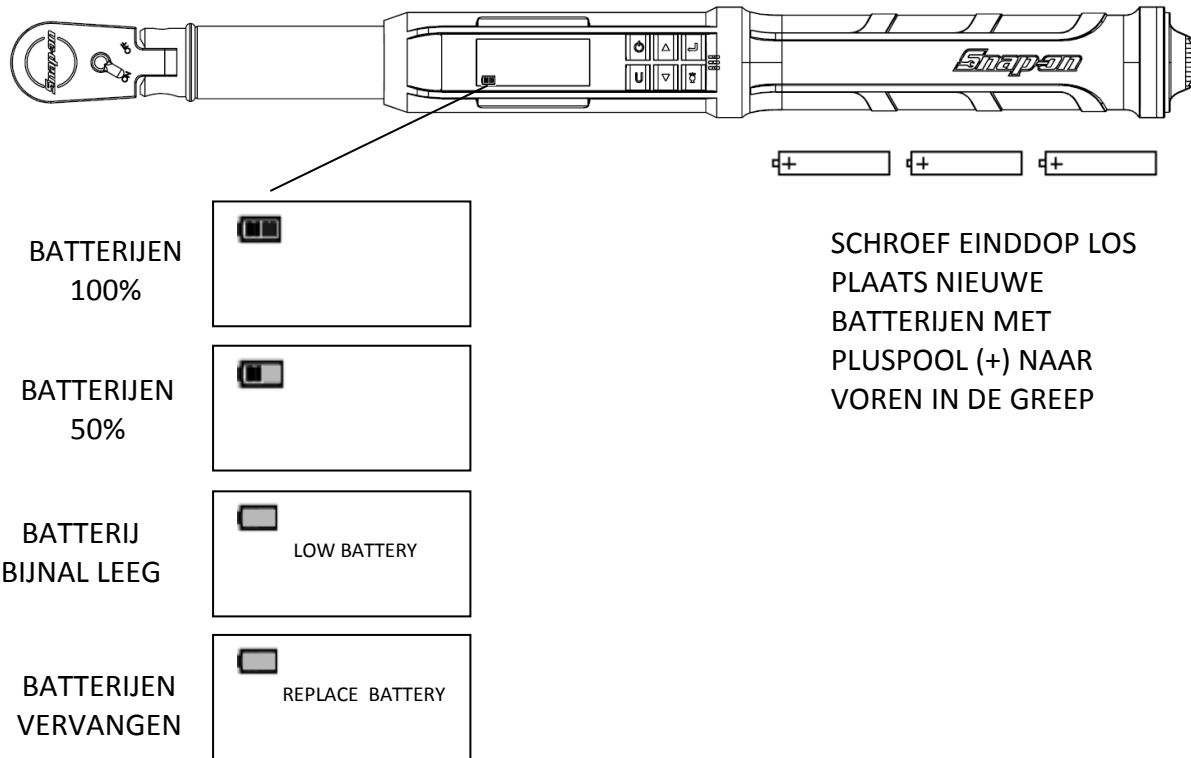

*Opm.: Bij het vervangen van batterijen onthoudt de real time-klok de datum en tijd 20 minuten lang.*

*Opm.: Draai de einddop linksom om hem los te schroeven.*



*Opm.: Als het bericht 'Replace Battery' (batterijen vervangen) wordt weergegeven, zal de sleutel pas weer werken nadat de batterijen zijn vervangen. Alleen de knop **STROOM**  werkt nog, en wordt gebruikt om de sleutel meteen uit te schakelen.*

## • Geheugenindicators

GEGEVENS IN GEHEUGEN		Er zijn minder dan 50 koppel- en hoekrecords in het geheugen opgeslagen.
GEHEUGEN VOL		Er zijn 50 koppel- en hoekrecords in het geheugen opgeslagen. De oudste record wordt door de eerstvolgende record vervangen.
GEHEUGEN- FOUT		Fout bij lezen of schrijven geheugen. Breng de sleutel terug naar een Snap-on reparatiecentrum als deze fout ook na het wissen van het geheugen aanhoudt.

# ERKENDE SNAP-ON REPARATIECENTRA

## VS

**Eastern Repair Center**  
6320 Flank Drive  
Harrisburg, PA 17112  
Telefoon: 717-652-7914  
Fax: 717-652-7123

**Northern Repair Center**  
3011 E. State Rt. 176, Dock A  
Crystal Lake, IL 60014  
Telefoon: 815-479-6850  
Fax: 815-479-6857

**Western Repair Center**  
2151 Challenger Way  
Carson City, NV 89706-0753  
Telefoon: 775-883-8585  
Fax: 775-883-8590

## CANADA

**Western Repair Centre**  
7403-48 Street SE  
Calgary, Alberta  
Canada, T2C-4H6  
Telefoon: 403-720-0525  
Fax: 403-720-0524

## INTERNATIONAAL

**United Kingdom Repair Center**  
Telford Way  
Telford Way Industrial Estate  
Kettering, Northants  
NN16 8UN Engeland  
Telefoon: 44-1-536-413855  
Fax: 44-1-536-413900

**Australia Repair Centre**  
Snap-on Tools Australia PTY.LTD  
Unit 6/110 Station Road  
Seven Hills, NSW 2147  
Australië  
Telefoon: 61-2-8937-9155  
Fax: 61-2-9624-2445

**Singapore Repair Center**  
Snap-on Tools Singapore PTE Ltd  
128 Tagore Lane, Blk 4 Singapore  
787554 Republic of Singapore  
Telefoon: 011-65-451-5570  
Fax: 011-65-451-5574

**Japan Repair Center**  
Snap-on Tools Japan K.K.  
3-5-12 Konan  
Minato-KU, Tokyo 108  
Japan  
Telefoon: 81-3-5463-1280  
Fax: 81-3-5463-1284

**Snap-on/SUN De Mexico**  
S.A. De C.V.  
Avenida Presidente Juarez No.  
2016  
Col Los Reyes Zona Industrial  
Tlalnepantla Edo De Mexico  
CP54070 MEXICO  
Telefoon: 52-55-53903122  
Fax: 52-55-53903259

### BELANGRIJKE INFORMATIE OVER HET MILIEU:

1.



DEZE APPARATUUR BEVAT  
GEVAARLIJKE MATERIALEN DIE  
SCHADELIG KUNNEN ZIJN VOOR HET  
MILIEU.

2. DEZE APPARATUUR MAG NIET ALS  
HUISHOUDELIJK AFVAL WORDEN  
AANGEBODEN.  
STUUR HET PRODUCT TERUG AAN DE  
DISTRIBUTEUR OF BIED HET AAN BIJ  
EEN SPECIALE INZAMELAAR.

DANK U VOOR UW ZORG OM HET MILIEU!

**Snap-on Tools Company**  
Kenosha, WI 53141-1410 USA



Gedrukt in de VS

# **ISTRUZIONI CAUTELARI IMPORTANTI**



## **AVVERTENZA *Pericolo di schegge vaganti.***

Un serraggio eccessivo può causare rotture. Forzando fermi flessibili contro teste duttili si corre il rischio di rompere le viti. Una chiave angolare calibrata erroneamente potrebbe provocare la rottura del pezzo in lavorazione o dell'utensile. Utensili manuali, bussole o accessori rotti possono provocare infortuni. Una forza eccessiva su dadi a croce o conici può causare lo slittamento della chiave.

- Leggere **attentamente questo manuale** prima di utilizzare la CHIAVE ELETTRONICA.
- Per garantire la precisione, il movimento di lavoro non deve essere angolare.
- Per la propria incolumità e per evitare di danneggiare la chiave, seguire le direttive di categoria per il serraggio delle viti e la meccanica professionale.
- Per mantenerne la precisione, è necessario ricalibrare l'utensile periodicamente.
- È necessario che l'operatore e le persone circostanti indossino appositi occhiali di sicurezza.**
- Verificare sempre che tutti i componenti, compresi eventuali riduttori, prolunghe, alberini e bussole, siano omologati per una coppia uguale o superiore a quella applicata.
- Durante l'utilizzo di questo utensile, rispettare sempre tutte le indicazioni e istruzioni cautelari fornite dai rispettivi produttori di accessori e impianti.
- Per il serraggio, utilizzare sempre una bussola di dimensione adatta per quella vite.
- Non utilizzare bussole che presentino segni di usura o di rottura.
- Sostituire le viti con bordi smussati.
- Per evitare di danneggiare la chiave:** non usare mai la chiave quando è spenta. Accenderla sempre per poter misurare la coppia di serraggio applicata a ogni uso.
  - Non premere il tasto **ALIMENTAZIONE**  quando la chiave è in tiro o in movimento.
  - Non utilizzare mai questa chiave per allentare viti, dadi e bulloni.
  - Non utilizzare prolunghe, come un tubo, sul manico della chiave.
  - Prima di procedere, controllare che la portata della chiave corrisponda o superi quella richiesta per il lavoro.
  - In caso di caduta accidentale, controllare la calibrazione.
- Controllare che la levetta di direzione del cricchetto sia ingranata nella posizione giusta.
- Controllare la calibrazione della chiave anche al solo sospetto che sia stata ecceduta la sua portata.
- Non forzare la testa di viti e bulloni duttili contro i fermi.
- Tirare sempre - e mai spingere - il manico della chiave e bilanciare la propria posizione in modo da rimanere sempre in equilibrio anche nell'eventualità di un cedimento.
- Non tentare di ricaricare le celle delle batterie alcaline.
- Conservare sempre la chiave in un luogo asciutto.
- Estrarre sempre le batterie quando si conserva una chiave per un periodo superiore a tre mesi.



## **AVVERTENZA *Rischio scosse elettriche.***

Le scosse elettriche possono causare infortuni. Il manico in plastica non è isolato.

Non utilizzare su circuiti elettrici sotto tensione.

## **CONSERVARE QUESTE ISTRUZIONI**

### **ESONERO DI RESPONSABILITÀ:**

Non si garantisce l'uso della chiave TechAngle® nei Paesi membri della CEE dove le istruzioni per l'uso non sono in lingua locale. Contattare la Snap-on per l'eventuale traduzione.

# Dati tecnici

## Tipo testa

- Attacco quadro a 72 o 80 dentini, snodo sigillato

## Display

- TIPO DISPLAY: LCD a matrice di punti (risoluzione da 192 x 65)
- DIREZIONE DI VISUALIZZAZIONE: alle 6:00
- RETROILLUMINAZIONE: BIANCA (LUCE LED)

## Tastiera sigillata

 **ALIMENTAZIONE:** controlla l'accensione/spegnimento e l'azzeramento della coppia e dell'angolo

 **INVIO:** seleziona la modalità di misurazione e l'accesso al menu

 **SU:** aumenta le impostazioni della coppia e dell'angolo e sposta in su la navigazione del menu

 **GIÙ:** diminuisce le impostazioni della coppia e dell'angolo e sposta in giù la navigazione del menu

 **UNITÀ:** seleziona le unità di misura (ft-lbs, in-lbs, Nm, Kgm, Kg-cm, dNm) e accede al menu PSET (preimpostazioni)

 **RETROILLUMINAZIONE LCD:** illumina lo schermo e richiama l'ultimo valore di picco della coppia o dell'angolo

## Funzioni

- Set: imposta il valore desiderato della coppia o dell'angolo
- Track: visualizza in tempo reale il valore della coppia o dell'angolo raggiunto e lo indica con l'accensione di una serie di spie
- Peak Hold: lampeggia per 10 sec. ad indicare il picco del valore di coppia - o alternando l'indicazione coppia/angolo - a fine corsa
- Peak Recall: premendo questo tasto, visualizza l'ultimo valore di picco della coppia o di quello coppia/angolo
- Memory: visualizza gli ultimi 50 valori di picco della coppia o di quella coppia/angolo in memoria

## Precisione

- Temperatura: @ 22°C (72°F)
- Angolo:  $\pm 1\%$  di lettura  $\pm 1^\circ$  a una velocità angolare  $> 10^\circ/\text{sec} < 180^\circ/\text{sec} \pm 1^\circ$  dell'ambiente di prova

- Coppia: 

	DX	SX	
Coppia:	$\pm 2\%$	$\pm 3\%$	di lettura, dal 20% al 100% su tutta la scala
	$\pm 4\%$	$\pm 6\%$	di lettura, dal 10% al 19% su tutta la scala
	$\pm 8\%$	$\pm 10\%$	di lettura, dal 5% al 9% su tutta la scala

## Dimensioni: Lunghezza / Peso

Modello	Lunghezza	Peso
ATECH1FR240B	41,7 cm.	0,86 Kg.
ATECH2FR100B	45,5 cm	1,050 Kg.
ATECH3FR250B	67,5 cm.	1,670 Kg.

## Range valori preimpostati

- ANGOLO: da 0 a 360° dx o sx (risoluzione display 1°)
- COPPIA: (Range display e risoluzione indicati in basso)

Modello	Attacco quadro	ft-lb	in-lbs	Nm	Kgm	kg-cm	dNm	sovraccarico (ft-lb)
ATECH1FR240B	¼ in.	1,00-20,00	12,0-240,0	1,36-27,12	N/D	13,8-276,5	13,6-271,2	25
ATECH2FR100B	⅜ in.	5,0-100,0	60-1200	6,8-135,6	N/D	69-1383	68-1356	125
ATECH3FR250B	½ in.	12,5-250,0	150-3000	16,9-339,0	1,73-34,56	N/D	N/D	312

**Temperatura di esercizio:** da 0°F a 130°F (da -18°C a 54°C)

**Temperatura di conservazione:** da 0°F a 130°F (da -18°C a 54°C)

**Variazione della misurazione:** ANGOLO: -0,12 gradi angolari per grado C  
COPPIA: +0,01% della lettura per grado C

**Umidità:** fino al 90% non-condensante

**Batterie:** tre batterie "AA" di tipo alcalino, fino a 40 ore di funzionamento continuo

**Spegnimento automatico di default:** Dopo 2 minuti di inattività – (regolabile, vedere Impostazioni avanzate)



# Istruzioni per l'utente

## • Funzioni basilari (Guida rapida)

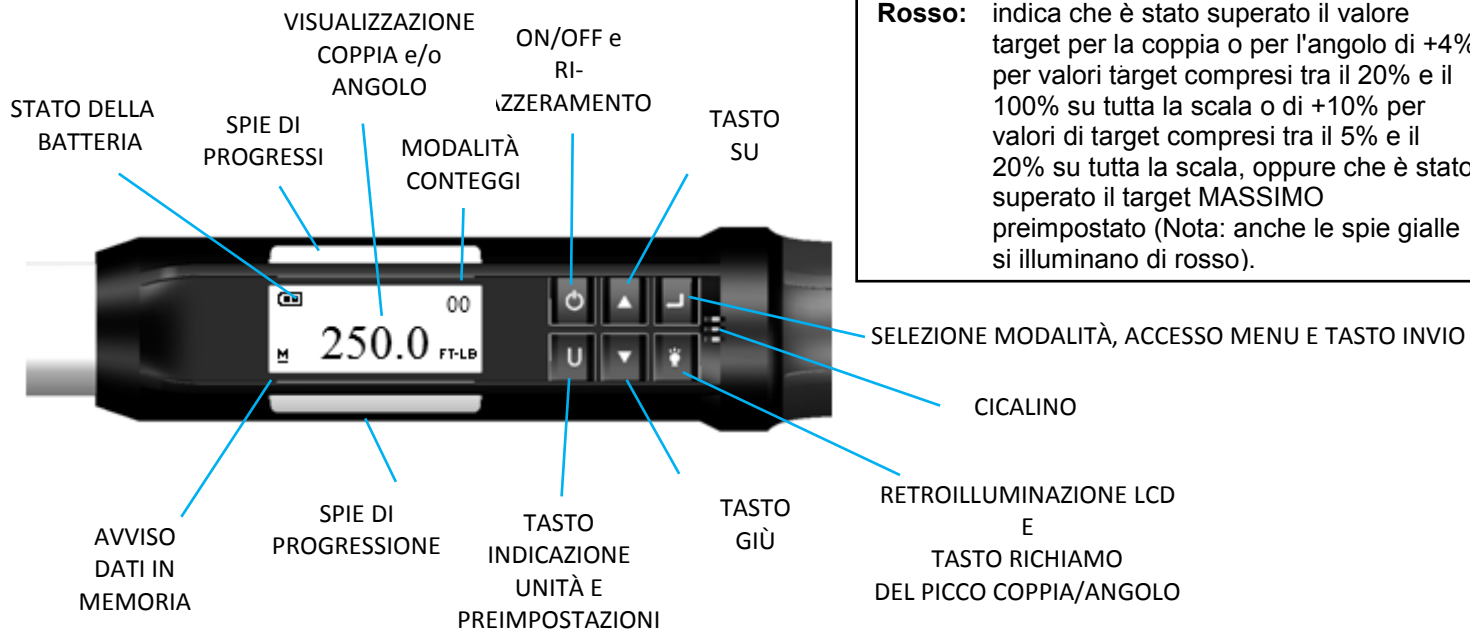

### SPIE DI PROGRESSIONE

**Giallo:** la prima spia indica il raggiungimento del 40% del valore target impostato per la coppia o per l'angolo. La seconda spia indica il raggiungimento del 60% di tale valore, mentre la terza spia indica il raggiungimento dell'80%.

**Verde:** indica che il valore impostato per la coppia o per l'angolo è stato raggiunto.

**Rosso:** indica che è stato superato il valore target per la coppia o per l'angolo di +4% per valori target compresi tra il 20% e il 100% su tutta la scala o di +10% per valori di target compresi tra il 5% e il 20% su tutta la scala, oppure che è stato superato il target MASSIMO preimpostato (Nota: anche le spie gialle si illuminano di rosso).

Figura 1

**Installare tre batterie nuove tipo "AA" nel manico della chiave.**

### Sequenza di accensione della chiave

*Nota: non accendere la chiave quando si trova sotto tiro, altrimenti l'azzeramento di calibrazione sarà errato e di conseguenza il valore indicato non sarà attendibile. Nel caso accadesse, riazzerare la chiave premendo brevemente il tasto **ALIMENTAZIONE**  quando l'utensile si trova su una superficie stabile e non a tiro.*

#### 1. Accendere la chiave.

Premere brevemente il tasto **ALIMENTAZIONE** . Sul display appare prima il marchio della Snap-on e poi la schermata di riazzeramento della coppia. Nel caso la misurazione precedente fosse riferita all'angolo, allora alla schermata di riazzeramento dell'angolo seguirà quella di riazzeramento della coppia. Una volta completato il riazzeramento, appare la schermata per il valore target della coppia o di quello dell'angolo, secondo la modalità della misurazione effettuata per ultima.

#### 2. Selezionare la modalità di misurazione.

Alternare le schermate TORQUE e ANGLE premendo ripetutamente il tasto **INVIO** .

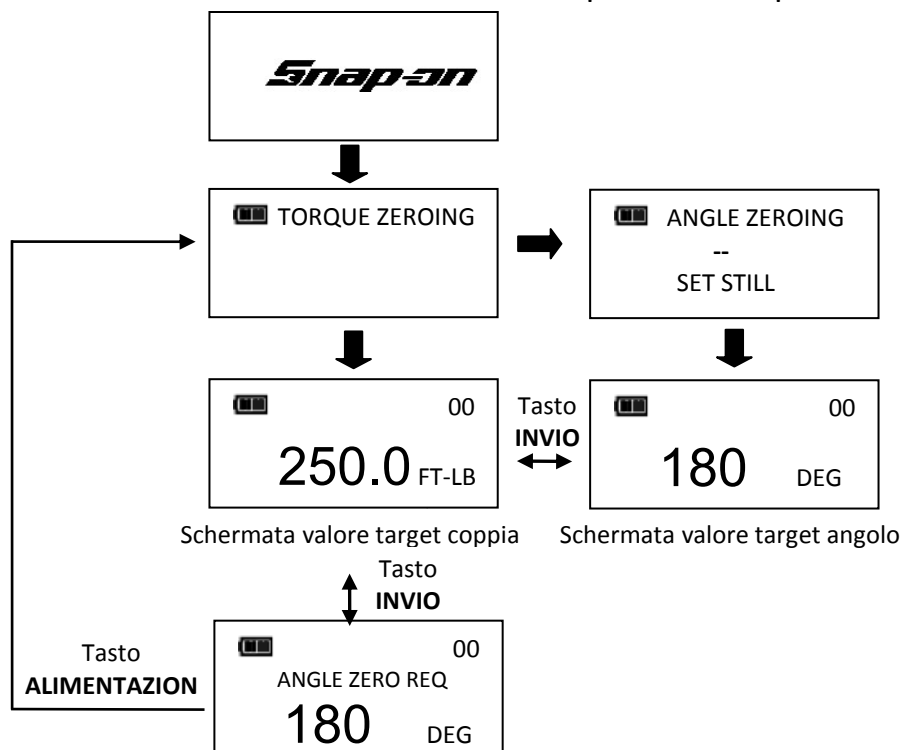



*Nota: nel caso la chiave venisse accesa in modalità di misurazione della sola coppia, l'angolo non verrà azzerato fino a quando non si passa alla modalità di misurazione dell'angolo; a quel punto, l'azzeramento della coppia e dell'angolo si avvia automaticamente dopo 2 secondi. Collocare la chiave su una superficie stabile e non a tiro.*

*Nota: premendo il tasto **INVIO**  durante la fase di azzeramento la sequenza si interromperà per permettere all'utente di selezionare un'altra modalità di misurazione.*

### **Modalità coppia**

1. Impostare il valore target.

Utilizzare i tasti **SU** /**GIÙ**  per cambiare il valore target della COPPIA.





2. Selezionare le unità di misura.

Premere ripetutamente il tasto **UNITÀ**  nella schermata valore target della COPPIA fino a visualizzare le unità di misura desiderate.

3. Serrare al valore di COPPIA.

Impugnare il centro del manico, (NON tirare sul coperchio delle batterie) e serrare lentamente la vite facendo accendere tutte le spie di progressione fino al verde e fino ad avvertire una leggera vibrazione sul manico accompagnata dal suono del cicalino per ½ secondo.

4. Rilasciare il tiro.

Notare che la lettura del valore di picco della COPPIA lampeggia per 10 secondi sul display a cristalli liquidi. Premendo il tasto **RETROILLUMINAZIONE**  mentre il valore di picco della coppia lampeggia, la visualizzazione di tale valore continua fino a quando non si rilascia quel tasto. Premere brevemente il tasto **SU** /**GIÙ** , **INVIO**  o **UNITÀ**  per tornare immediatamente alla schermata valore target della COPPIA. Un nuovo ciclo di misurazione della COPPIA si avvierà automaticamente non appena si rimette la chiave a tiro.

5. Richiamo della lettura del valore di picco della COPPIA

Per richiamare l'ultima misurazione del valore di picco della COPPIA, tenere premuto il tasto **RETROILLUMINAZIONE**  per 3 secondi circa. Il valore di picco della COPPIA lampeggerà per 10 secondi.



### **Modalità angolo**

*Nota: non mettere la chiave sotto tiro durante la fase di azzeramento della coppia e dell'angolo, altrimenti l'azzeramento di calibrazione sarà errato e di conseguenza il valore indicato per l'angolo non sarà attendibile. Nel caso accadesse, riazzerare la chiave premendo brevemente il tasto **ALIMENTAZIONE**  quando l'utensile si trova su una superficie stabile e non a tiro.*

1. Azzeramento angolo

Nel caso apparisse il messaggio "ANGLE ZERO REQ" ad indicare che bisogna azzerare l'angolo, attendere 2 secondi per permettere il completamento automatico di tale sequenza prima di mettere la chiave in tiro o di muoverla.





2. Impostazione del valore target.

Utilizzare i tasti **SU** /**GIÙ**  per cambiare il valore target dell'ANGOLO.

3. Serrare al valore di coppia e ruotare la chiave.

Impugnare il centro del manico, (NON tirare sul coperchio delle batterie), serrare lentamente la vite e ruotare la chiave a velocità moderata ma costante facendo accendere tutte le spie di progressione fino al verde e fino ad avvertire una leggera vibrazione sul manico accompagnata dal suono del cicalino per ½ secondo.

4. Rilasciare il tiro.

Notare che la lettura del valore di picco della COPPIA e dell'ANGOLO lampeggia per 10 secondi sul display a cristalli liquidi. Premendo il tasto **RETROILLUMINAZIONE**  mentre il valore di picco dell'angolo lampeggia, la visualizzazione di tale valore continua fino a quando non si rilascia quel tasto. Premere brevemente il tasto **SU** /**GIÙ** , **INVIO**  o **UNITÀ**  per tornare immediatamente alla schermata valore target dell'ANGOLO. Continuando a serrare (con il cricchetto) prima che appare la schermata con

il valore target, la misura dell'ANGOLO continua ad accumularsi in sincronia con la rotazione della chiave.

#### 5. Richiamo della lettura del valore di picco dell'ANGOLO

Per richiamare l'ultima misurazione del valore di picco dell'ANGOLO, premere e tenere premuto il tasto **RETROILLUMINAZIONE**  per 3 secondi circa. I valori di picco della COPPIA e dell'ANGOLO appariranno alternativamente per 10 secondi.

#### Modalità conteggio cicli

La modalità conteggio cicli TechAngle® viene usata per indicare quante volte la chiave ha raggiunto il valore target della coppia durante la misurazione di quest'ultima o il valore target dell'angolo durante la sua misurazione.

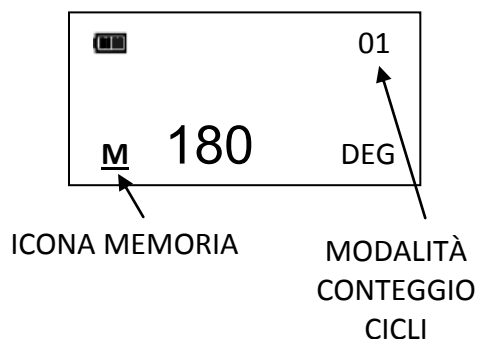





#### Modalità conteggio cicli di coppia e angolo

1. Il contatore numerico in alto a destra della schermata valore target della coppia o dell'angolo aumenterà ogni volta che il serraggio al valore target della coppia o dell'angolo è stato raggiunto.
2. Ogni volta che si passa dalla modalità di coppia a quella di angolo o viceversa utilizzando il tasto **INVIO**  o viene cambiato il valore target, il contatore numerico ritorna a 00. Il contatore NON SI AZZERA durante la fase di riassetto della calibrazione oppure quando si accede/esce dal menu oppure quando si spegne la chiave.
3. L'icona Memoria si accende quando è stato memorizzato almeno un dato sul ciclo di coppia o di angolo.

#### Menu principale

Nel Menu principale vengono visualizzate tutte le informazioni sul funzionamento della chiave.

1. Dalla schermata valore target della coppia o dell'angolo, premere il tasto **INVIO**  per 3 secondi.
2. Usare i tasti **SU**  / **GIÙ**  per evidenziare la voce del menu che si intende selezionare e premere il tasto **INVIO** .





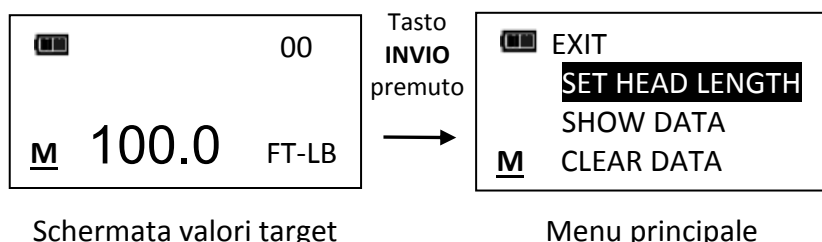





Voci del menu:

- EXIT - Esce dal menu principale e ritorna alla schermata valore target.
  - SET HEAD LENGTH - Visualizza la schermata dove indicare la lunghezza della testa della chiave.
  - SHOW DATA - Visualizza i dati memorizzati della coppia e dell'angolo.
  - CLEAR DATA - Cancella i dati memorizzati della coppia e dell'angolo.
  - CYCLE COUNT - Visualizza la schermata con il conteggio dei cicli di coppia/angolo.
  - SETTINGS - Visualizza il menu con le impostazioni avanzate (vedere la sezione Impostazioni avanzate).
  - CONFIGURE - Visualizza il menu con le configurazioni avanzate (vedere la sezione Configurazioni avanzate).
3. Per uscire dal menu principale e ritornare alla schermata del valore target della coppia o dell'angolo, premere il tasto **INVIO**  quando è evidenziata la voce **EXIT** sul menu.



## Impostazione della lunghezza della testa

*Nota: nel caso si utilizzasse un riduttore o una prolunga, sarà possibile indicarne qui la lunghezza per compensare la differenza di dimensione rispetto alla chiave originale senza dover ripetere la calibrazione.*

1. Per indicare la lunghezza della testa, dalla schermata valore target della coppia o dell'angolo, premere il tasto **INVIO**  per 3 secondi.
2. Con evidenziata la voce **SET HEAD LENGTH** nel menu, premere brevemente il tasto **INVIO** .
3. Appare così la schermata per l'impostazione della lunghezza della testa. La lunghezza di default è quella indicata al momento della calibrazione. Utilizzare i tasti **SU** /**GIÙ**  per aumentare o diminuire la lunghezza della testa. Mantenendo premuti.
4. I tasti **SU** /**GIÙ** , il valore di aumento/diminuzione scorrerà più velocemente. Premendo i tasti **SU** /**GIÙ**  contemporaneamente, la lunghezza della testa ritorna a zero.
5. L'unità di default per la lunghezza è in pollici. Premere il tasto **UNITÀ** **U**  per cambiarla in millimetri.
6. Premendo il tasto **INVIO**  dopo aver impostato la lunghezza si ritorna al menu principale. Ogni volta che la lunghezza viene cambiata dal valore di default, sulla schermata dei valori target appare il messaggio "OFFSET IN USE".

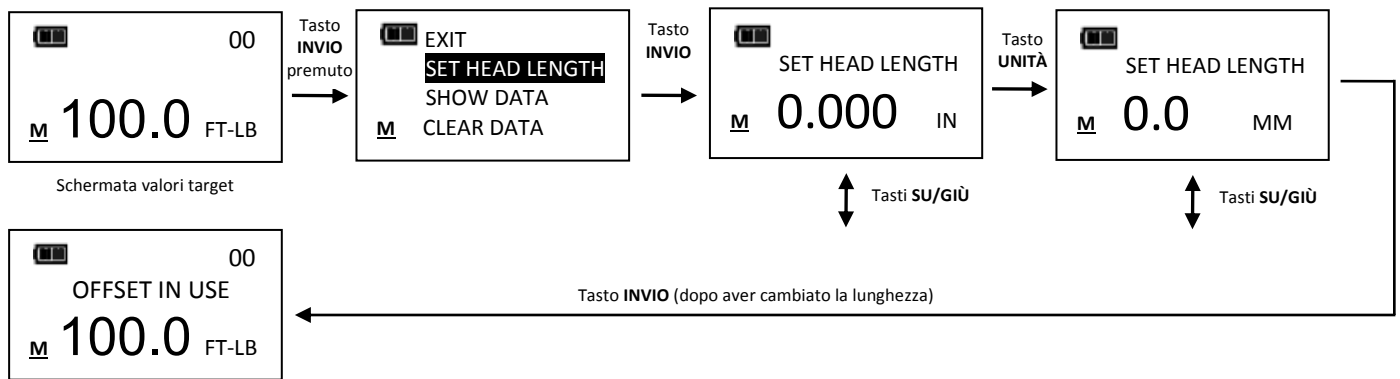

*Nota: La lunghezza della testa indicata deve corrispondere alla lunghezza di correzione misurata dal centro dell'alberino al centro della vite.*

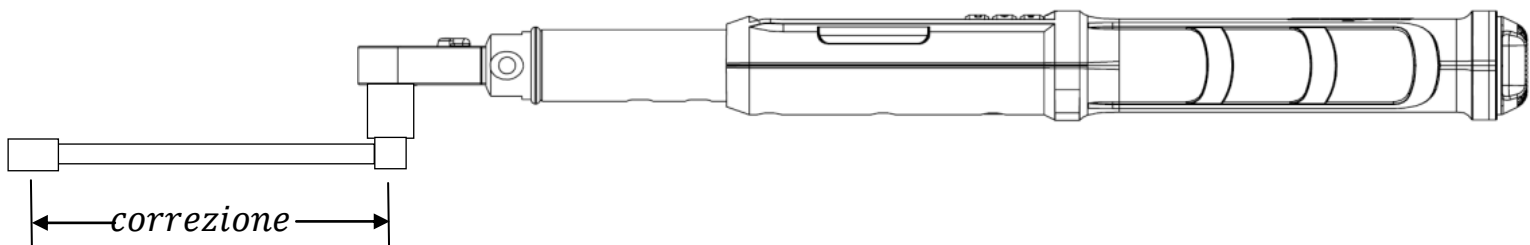

## Uso di valori di correzione negativi

*Nota: indicare un valore di correzione negativo quando la chiave viene usata in direzione inversa.*

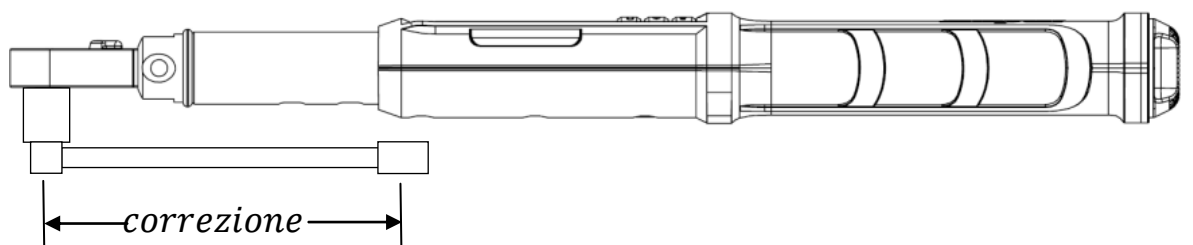

Quando la lunghezza di correzione (offset) è un valore negativo, il valore target massimo di serraggio è limitato dalle seguenti formule:

240 in-lb wrench:  
Maximum Target Torque =  
offset \* 24 + 240

Offset	Max Target
-1"	216 in-lb
-2"	192 in-lb
-3"	168 in-lb
-4"	144 in-lb

100 ft-lb wrench:  
Maximum Target Torque =  
offset \* 8 + 100

Offset	Max Target
-1"	92 ft-lb
-2"	84 ft-lb
-3"	76 ft-lb
-4"	68 ft-lb

250 ft-lb wrench:  
Maximum Target Torque =  
offset \* 12 + 250

Offset	Max Target
-1"	238 ft-lb
-2"	226 ft-lb
-3"	214 ft-lb
-4"	202 ft-lb

*Nota: durante l'utilizzo di una correzione negativa, l'indicazione di una coppia target maggiore dei valori massimi sopraindicati potrebbe causare un errore di serraggio eccessivo prima ancora del raggiungimento della coppia target stessa. Si rischia anche di danneggiare la chiave.*

### Visualizzazione dei dati di coppia e dell'angolo in memoria

I dati di coppia vengono memorizzati dopo ogni ciclo di serraggio che abbia raggiunto il valore target. I dati di coppia e dell'angolo vengono memorizzati dopo ogni ciclo angolare che abbia raggiunto il valore target. L'indicatore Memoria appare solo quando i dati vengono conservati in un supporto di memoria non-volatile.

1. Per visualizzare i dati di coppia e dell'angolo in memoria, dalla schermata valore target della coppia o dell'angolo, premere il tasto **INVIO** per 3 secondi.
2. Evidenziare la voce **SHOW DATA** nel menu premendo i tasti **SU** / **GIÙ** e premere **INVIO** per visualizzare la schermata con la visualizzazione dei dati.
3. In questa schermata, far scorrere ciascun dato memorizzato premendo i tasti **SU** / **GIÙ** .

Ad esempio: 02 = Mostra il contatore con l'elenco dei dati: TQ = Valore di picco della coppia  
01 = Mostra il contatore con l'elenco dei dati: TQ = Valore di picco della coppia  
ANG = Valore di picco dell'angolo

4. Premendo il tasto **INVIO** all'interno della schermata con la visualizzazione dei dati si ritorna al menu principale.

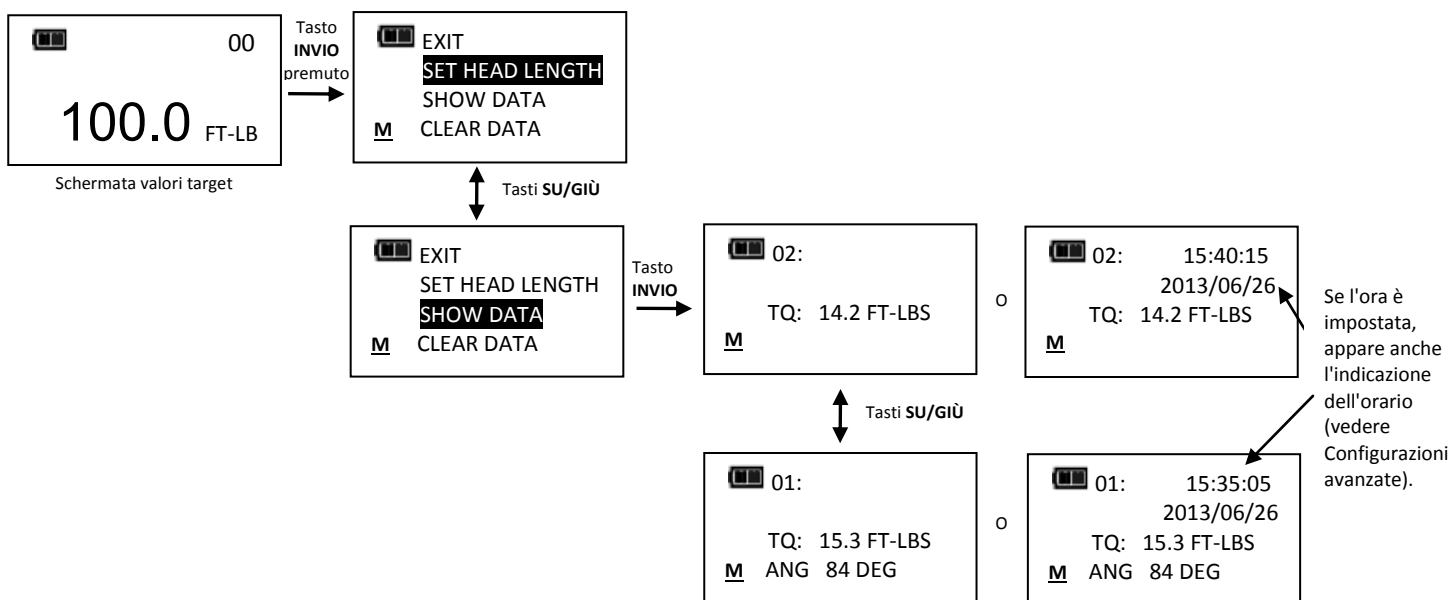

*Nota: è possibile mantenere in memoria un massimo di 50 dati. Al raggiungimento di tale limite appare il segnale di memoria piena. I dati più vecchi verranno sostituiti da quelli più recenti.*

### Eliminazione dei dati di coppia e dell'angolo in memoria





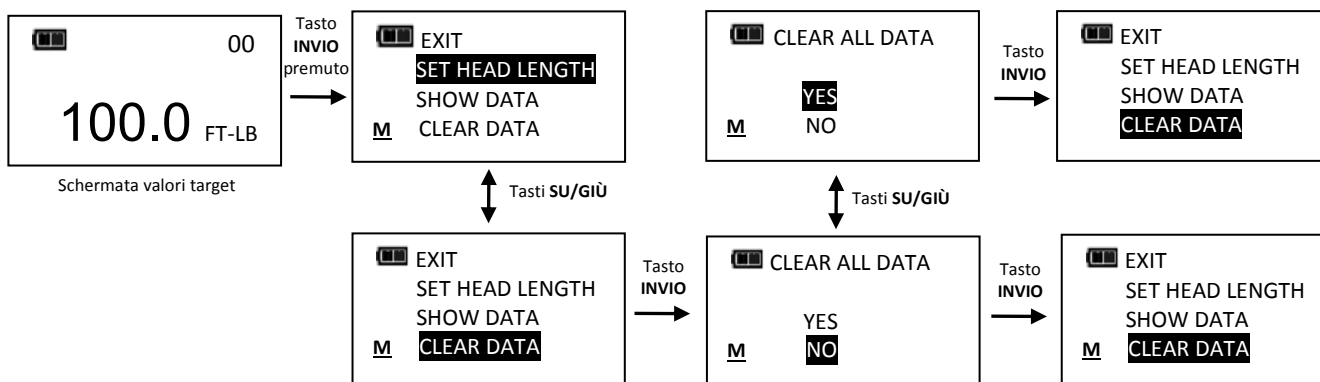

1. Dalla schermata valore target della coppia o dell'angolo, premere il tasto **INVIO** per 3 secondi.
2. Evidenziare la voce **CLEAR DATA** sul menu premendo i tasti **SU** / **GIÙ** e quello **INVIO** subito dopo per visualizzare la schermata per la cancellazione di tutti i dati.

- Nella schermata CLEAR ALL DATA, evidenziare la voce **YES** sul menu per eliminare tutti i dati in memoria oppure la voce **NO** per uscire senza eliminare nessun dato.
- Premere il tasto **INVIO**  dopo aver effettuato la selezione.



### Visualizzazione e azzeramento del contatore dei cicli della chiave

Ogni volta che il valore target della coppia o dell'angolo viene raggiunto, il conto dei cicli della chiave aumenta. Il numero massimo di cicli sul contatore è 999999.

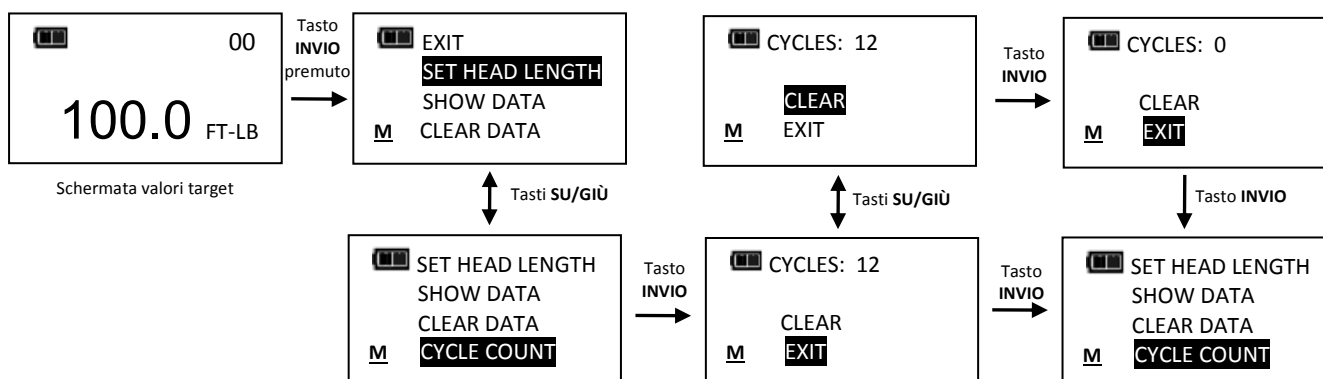

- Dalla schermata valore target della coppia o dell'angolo, premere il tasto **INVIO**  per 3 secondi.
- Evidenziare la voce **CYCLE COUNT** nel menu utilizzando i tasti **SU** /**GIÙ** .
- Premere il tasto **INVIO**  per visualizzare la schermata dei cicli.
- Per uscire dalla schermata dei cicli senza azzerare il conteggio, premere il tasto **INVIO**  quando è evidenziata la voce **EXIT** nel menu.
- Per resettare i cicli della chiave su 0, evidenziare la voce **CLEAR** nel menu e premere il tasto **INVIO**  subito dopo.
- La voce **EXIT** nel menu si evidenzia automaticamente non appena si azzerà il conteggio. Premere il tasto **INVIO**  per ritornare al menu principale.



### Valori target preimpostati (PSET)

Tramite la funzione PSET è possibile preconfigurare 10 impostazioni target della coppia o dell'angolo, ciascuno con un valore minimo (target), uno massimo (oltre il range) e uno con il conteggio a gruppi. Le preimpostazioni PSET sono memorizzate su un supporto non-volatile in modo da essere mantenute anche quando la chiave è spenta.

### Aggiunta di un valore preimpostato di coppia

- Dalla schermata del valore target della coppia, selezionare l'unità di misura.
- Premere il tasto **UNITÀ** **U** per 3 secondi.
- Appare la schermata di conferma ADD PRESET. Evidenziare la voce **YES** usando os botões **SU** /**GIÙ**  e premere **INVIO**  subito dopo. Selezionando la voce **NO** si ritorna al menu principale senza aggiungere nessuna preimpostazione.
- Il valore target della coppia minima (MINIMUM TORQUE) rappresenta la forza di serraggio al raggiungimento della quale si accendono le spie verdi di progressione, suona il cicalino e il manico vibra. Il valore di coppia minima iniziale coincide con quello nella schermata valore target della coppia. È possibile impostare questo parametro su qualsiasi valore di coppia compreso nella

gamma di portata della chiave. Basta premere uno dei tasti **SU ▲/GIÙ ▼**. Una volta impostato il valore target della coppia, premere il tasto **INVIO ↵**.

5. Appare ora la schermata per la coppia massima (MAXIMUM TORQUE). Essa rappresenta la forza di coppia massima al raggiungimento della quale si accendono le spie rosse di progressione. Il valore di coppia massima inizialmente impostato sarà quello della coppia minima più il 4%. È possibile impostare questo parametro su un valore superiore a quello di coppia minima senza però superare il 10% del limite massimo di portata della chiave. Basta premere uno dei tasti **SU ▲/GIÙ ▼**. Una volta impostato il valore desiderato, premere il tasto **INVIO ↵**.
6. Appare ora la schermata per il conteggio a gruppi (BATCH COUNT). Il valore di default è zero. Il range di conteggio a gruppi varia da 0 a 99. Premere uno dei tasti **SU ▲/GIÙ ▼** per aumentare o diminuire il conteggio a gruppi. Se il conteggio a gruppi è impostato su zero, il contatore sale ogni volta che il valore target della coppia viene raggiunto. Se invece il conteggio a gruppi è impostato su un valore diverso da zero, il contatore decresce e si resetta sul valore originario quando il conteggio arriva a zero. Una volta impostato il valore desiderato, premere il tasto **INVIO ↵**.
7. Appare ora la schermata PSET per la preimpostazione dei valori target contrassegnata con la posizione successiva tra 01 a 10.
8. Per aggiungere altre preimpostazioni, premere ripetutamente il tasto **INVIO ↵** fino a visualizzare la schermata valore target della coppia e ripetere la procedura sopraindicata.

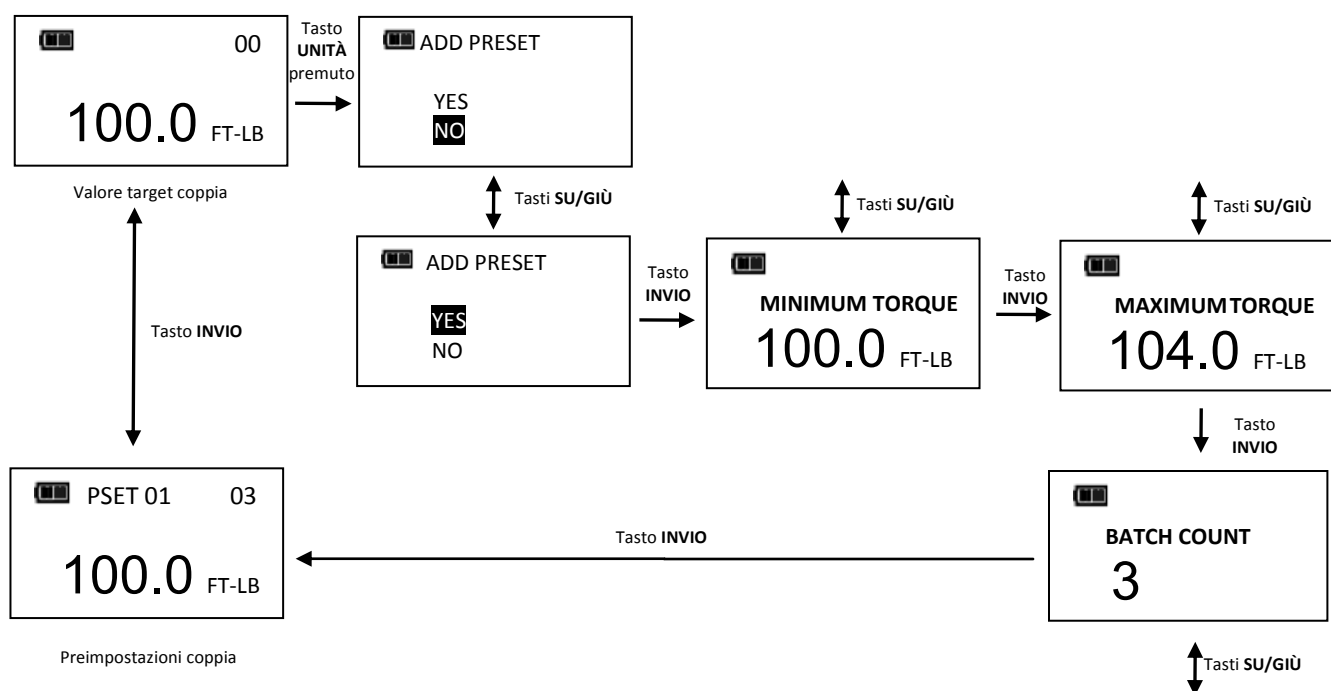

*Nota: per selezionare una preimpostazione memorizzata o la modalità valore target manuale di coppia o dell'angolo, premere il tasto **INVIO ↵** fino a visualizzare l'opzione desiderata.*

### Aggiunta di un valore preimpostato di angolo

1. Dalla schermata valore target dell'angolo, premere il tasto **UNITÀ U** per 3 secondi.
2. Appare la schermata di conferma **ADD PRESET** per aggiungere una preimpostazione. Evidenziare la voce **YES** con uno dei tasti **SU ▲/GIÙ ▼** e premere **INVIO ↵** subito dopo. Selezionando la voce **NO** si ritorna al menu principale senza aggiungere nessuna preimpostazione.
3. Appare la schermata per l'angolo minimo (MINIMUM ANGLE). Il valore target di angolo minimo (MINIMUM ANGLE) rappresenta il valore al raggiungimento del quale si accendono le spie verdi di progressione, suona il cicalino e il manico vibra. Il valore di angolo minimo iniziale coincide con quello nella schermata valore target dell'angolo. È possibile impostare il valore di angolo minimo tra 0 e 360°. Basta premere uno dei tasti **SU ▲/GIÙ ▼**. Una volta impostato il valore target dell'angolo, premere il tasto **INVIO ↵**.
4. Appare ora la schermata per l'angolo massimo (MAXIMUM ANGLE). Esso rappresenta il valore dell'angolo al raggiungimento del quale si accendono le spie rosse di progressione. Il valore di angolo massimo inizialmente impostato sarà quello dell'angolo minimo più il 4%. È possibile impostare l'angolo massimo su qualsiasi valore purché superiore a quello dell'angolo minimo. Basta premere uno dei tasti **SU ▲/GIÙ ▼**. Una volta impostato il valore desiderato, premere il tasto **INVIO ↵**.

5. Appare ora la schermata per il conteggio a gruppi (BATCH COUNT). Il valore di default è zero. Il range di conteggio a gruppi varia da 0 a 99. Premere uno dei tasti **SU ▲/GIÙ ▼** per aumentare o diminuire il conteggio a gruppi. Se il conteggio a gruppi è impostato su zero, il contatore sale ogni volta che il valore target dell'angolo viene raggiunto. Se invece il conteggio a gruppi è impostato su un valore diverso da zero, il contatore scende e si resetta sul valore originario quando il conteggio arriva a zero. Una volta impostato il valore desiderato, premere il tasto **INVIO ↵**.
6. Appare ora la schermata PSET per la preimpostazione dei valori target contrassegnata con la posizione successiva numerata da 01 a 10.
7. Per aggiungere altre preimpostazioni, premere ripetutamente il tasto **INVIO ↵** fino a visualizzare la schermata valore target dell'angolo e ripetere la procedura sopraindicata.

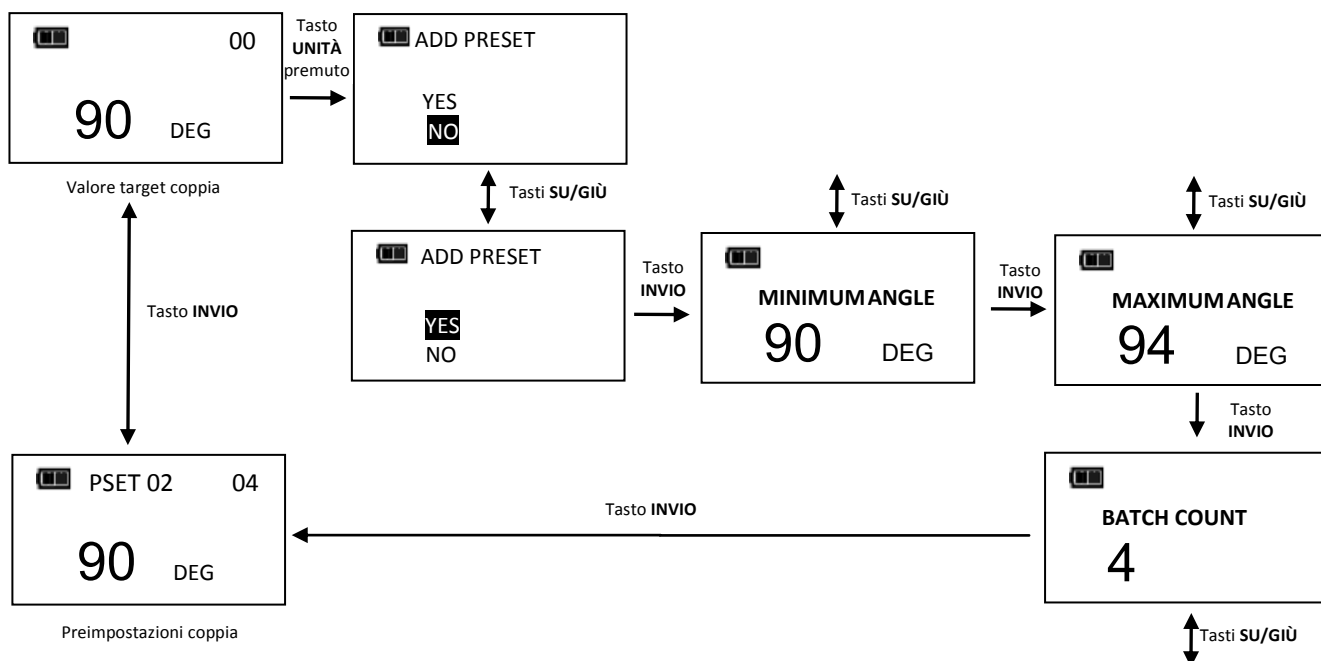

*Nota:* per selezionare una preimpostazione memorizzata o la modalità valore target manuale di coppia o dell'angolo, premere ripetutamente il tasto **INVIO ↵** fino a visualizzare l'opzione desiderata.

### **Modifica di una preimpostazione**

Tramite questa funzione è possibile modificare le preimpostazioni memorizzate nella chiave.

1. Dalla schermata delle preimpostazioni, premere il tasto **UNITÀ U** per 3 secondi.
2. Appare la schermata CHANGE PRESET.
3. Evidenziare la voce **EDIT** con uno dei tasti **SU ▲/GIÙ ▼** e premere **INVIO ↵** subito dopo.
4. Appare la schermata per la coppia o l'angolo minimo (MINIMUM TORQUE o ANGLE). Per cambiare il valore, basta premere uno dei tasti **SU ▲/GIÙ ▼**. Una volta impostato il valore target della coppia o dell'angolo, premere il tasto **INVIO ↵**.
5. Appare ora la schermata per la coppia o l'angolo massimo (MAXIMUM TORQUE o ANGLE). Per cambiare il valore, basta premere uno dei tasti **SU ▲/GIÙ ▼**. Una volta impostato il valore target della coppia o dell'angolo, premere il tasto **INVIO ↵**.
6. Appare ora la schermata per il conteggio a gruppi (BATCH COUNT). Per cambiare il valore, basta premere uno dei tasti **SU ▲/GIÙ ▼**. Una volta impostato il valore di conteggio a gruppi, premere il tasto **INVIO ↵**.
7. Appare ora la schermata PSET per la preimpostazione dei valori target contrassegnata con lo stesso numero di posizione.



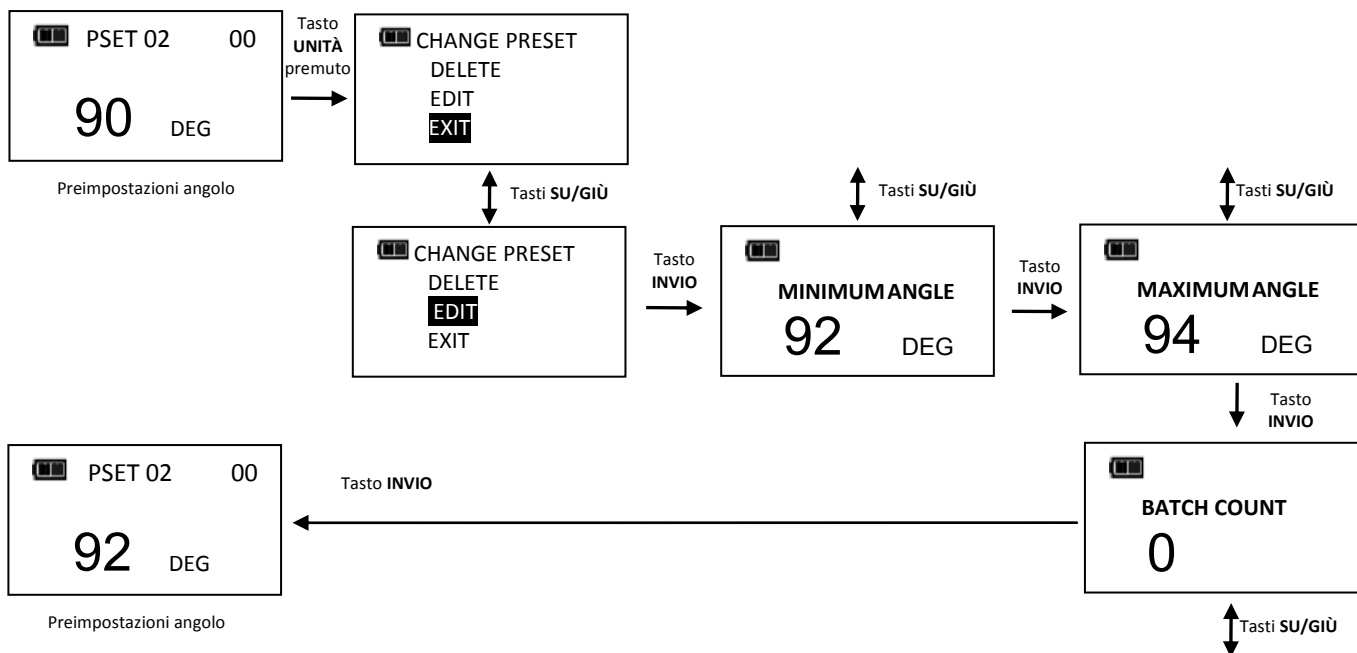





*Nota: premendo il tasto **INVIO**  con evidenziata la voce **EXIT** nel menu, si esce dalla schermata senza modificare nessuna preimpostazione.*

### Eliminazione di una preimpostazione

Tramite questa funzione è possibile cancellare le preimpostazioni memorizzate nella chiave.

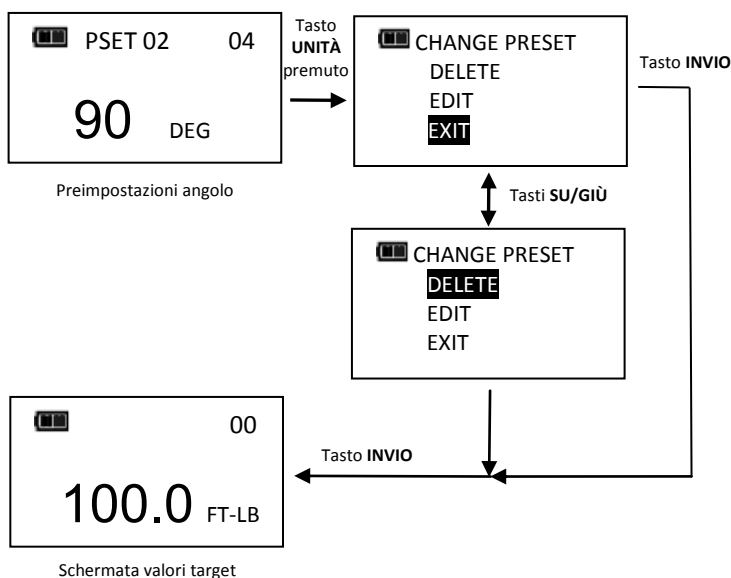
1. Dalla schermata con la preimpostazione da eliminare, premere il tasto **UNITÀ U** per 3 secondi.
2. Appare la schermata CHANGE PRESET.
3. Evidenziare la voce **DELETE** con uno dei tasti **SU** /**GIÙ**  e premere **INVIO** .
4. Appare ora la schermata dei valori target che non contiene più preimpostazioni da selezionare.







*Nota: premendo il tasto **INVIO**  con evidenziata la voce **EXIT** nel menu, si esce dalla schermata senza eliminare nessuna preimpostazione.*

*Nota: quando viene eliminata una preimpostazione, tutte le altre in memoria manterranno lo stesso numero di posizione. Quando viene aggiunta una nuova preimpostazione, le verrà assegnato il primo numero disponibile in sequenza.*

## • Impostazione avanzate

### Accesso alle impostazioni avanzate

Al menu per le impostazioni avanzate si accede tramite la voce **SETTINGS** nel menu principale.

1. Dalla schermata valore target della coppia o dell'angolo, premere il tasto **INVIO**  per 3 secondi.
2. Evidenziare la voce **SETTINGS** nel menu utilizzando i tasti **SU** /**GIÙ** .
3. Premere il tasto **INVIO**  per visualizzare la schermata delle impostazioni.

Voci del menu:

- **EXIT** - Esce dal menu Impostazioni e ritorna alla schermata valore target.

- SHOW INFO - Visualizza le informazioni operative della chiave.
- SLEEP TIME - Visualizza la schermata per l'impostazione dell'intervallo di spegnimento.
- LCD CONTRAST - Visualizza la schermata per la regolazione del contrasto dello schermo LCD.
- KEY BEEP - Visualizza la schermata per l'impostazione di attivazione/disattivazione dei bip di conferma pressione tasto.
- AUTO BACKLIGHT- Visualizza la schermata per attivare/disattivare l'accensione della retroilluminazione durante la misurazione.
- TOGGLE BACKLIGHT - Visualizza il tasto **RETROILLUMINAZIONE**  per alternare la selezione o per attivare/disattivare la funzione di timeout.
- VIBRATOR CONFIG - Visualizza la configurazione per attivare/disattivare la vibrazione al raggiungimento del valore target.

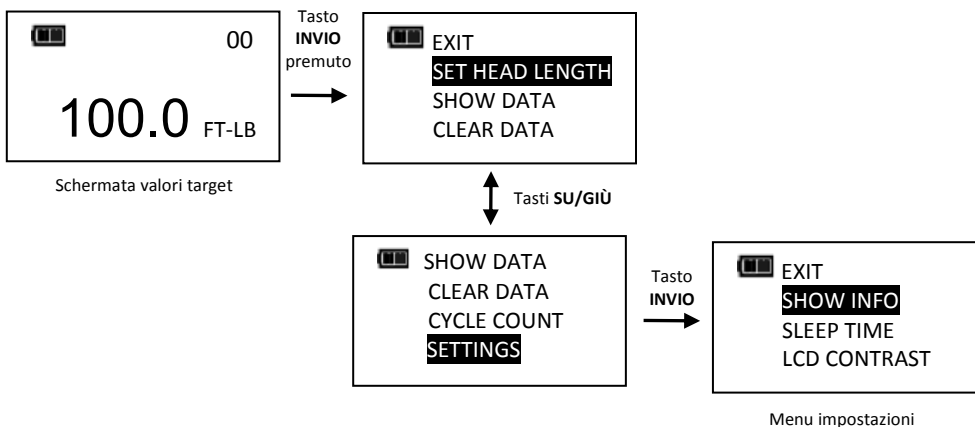

4. Per uscire dal menu delle impostazioni e ritornare alla schermata del valore target della coppia o dell'angolo, premere il tasto **INVIO**  quando è evidenziata la voce **EXIT** sul menu.



*Nota: tutte le impostazioni configurabili dall'utente sono memorizzate su un supporto non-volatile in modo da essere mantenute anche quando la chiave è spenta.*

### **Mostra informazioni**

La voce SHOW INFO nel menu visualizza le informazioni sul funzionamento della chiave.

1. Dal menu impostazioni, premere il tasto **INVIO**  quando è evidenziata la voce **SHOW INFO**.
2. Appare così l'omonima schermata.
3. Con uno dei tasti **SU** /**GIÙ**  è possibile scorrere lungo la schermata.

Informazioni sul funzionamento:

- CAL: data dell'ultima calibrazione della chiave.
- ISD: data di messa in uso.
- TCF: fattore di calibrazione della coppia.
- ACF: fattore di calibrazione dell'angolo.
- VER: versione software.
- OVR CNT: il contatore serraggi eccessivi indica quante volte si sono verificati casi di serraggio eccessivo con quella chiave (coppia >125% su tutta la scala).
- TQZ: Correzione coppia zero.
- ANZ: Correzione angolo zero.

4. Premendo il tasto **INVIO**  si esce dalla schermata Show Info e si ritorna al menu delle impostazioni.

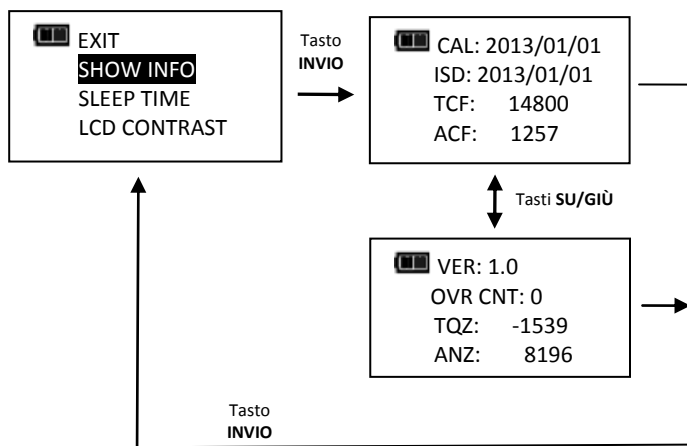

## Impostazione durata inattività

Tramite la funzione Sleep Time è possibile impostare l'intervallo che deve trascorrere dopo l'ultimo utilizzo o dopo l'ultima pressione di un tasto prima che la chiave si spenga.

1. Dal menu delle impostazioni, premere uno dei tasti **SU ▲/GIÙ ▼** per evidenziare la voce **SLEEP TIME** e premere il tasto **INVIO** **↵** subito dopo.
2. Appare così l'omonima schermata.
3. Utilizzare uno dei tasti **SU ▲/GIÙ ▼** per selezionare l'intervallo desiderato.

Intervalli selezionabili:

- 2 MIN (impostazione di fabbrica)
- 5 MIN
- 10 MIN
- 30 MIN
- 1 HR
- 2 HR
- 8 HR

4. Premere il tasto **INVIO** **↵** per accettare la selezione e uscire sul menu delle impostazioni.

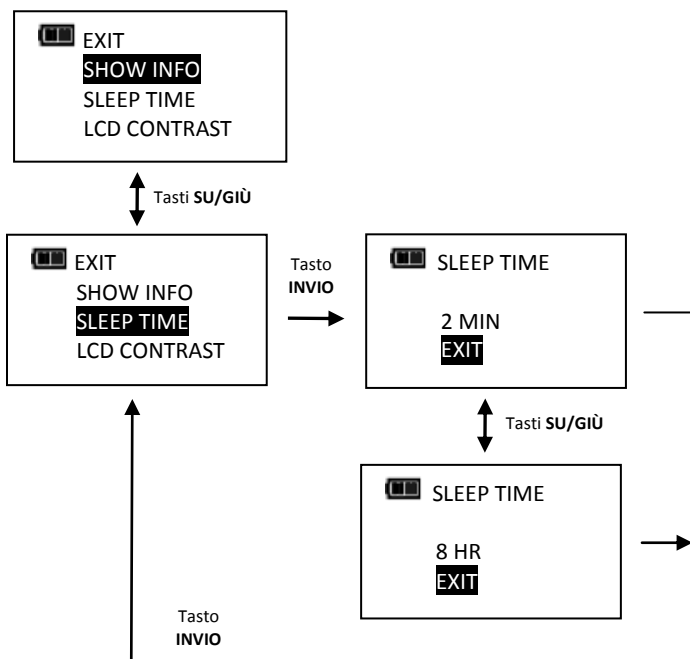

## Regolazione del contrasto dello schermo LCD

Tramite questa funzione è possibile regolare il contrasto dello schermo a cristalli liquidi per una visualizzazione ottimale.

1. Dal menu impostazioni, premere uno dei tasti **SU ▲/GIÙ ▼** per evidenziare la voce **LCD CONTRAST** e premere il tasto **INVIO** **↵** subito dopo.
2. Appare ora l'omonima schermata.
3. Utilizzare uno dei tasti **SU ▲/GIÙ ▼** mentre si osserva lo schermo per regolare il contrasto al livello desiderato.





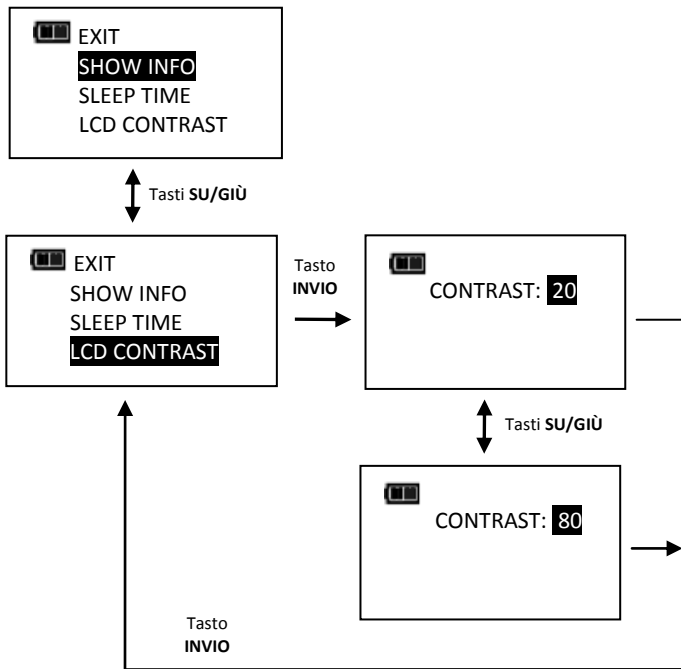

Livelli selezionabili: da 20 a 80 in multipli di 5 (impostazione di fabbrica = 40).

4. Premere il tasto **INVIO**  per accettare la selezione e uscire sul menu delle impostazioni.



### Impostazione del bip di conferma pressione tasto





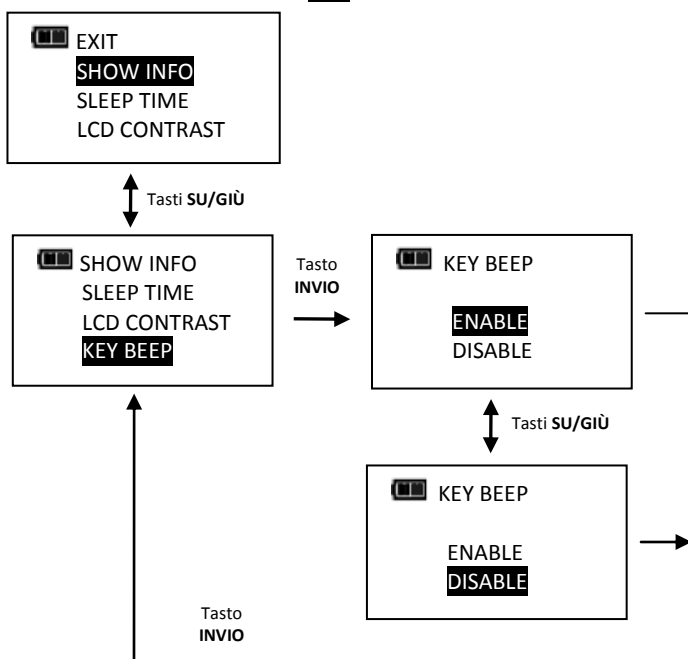

Tramite questa funzione è possibile attivare o disattivare il bip di conferma quando si preme un tasto.

1. Dal menu delle impostazioni, utilizzare uno dei tasti **SU**  / **GIÙ**  per evidenziare la voce **KEY BEEP** e premere il tasto **INVIO**  subito dopo.
2. Appare ora l'omonima schermata.
3. Utilizzare uno dei tasti **SU**  / **GIÙ**  per evidenziare la voce **ENABLE** (ATTIVA, impostazione di fabbrica) o **DISABLE** (DISATTIVA).
4. Premere il tasto **INVIO**  per accettare la selezione e uscire sul menu delle impostazioni.



### Impostazione per la retroilluminazione automatica

Tramite questa funzione è possibile attivare o disattivare l'accensione della retroilluminazione durante la misurazione della coppia o dell'angolo.

1. Dal menu delle impostazioni, premere uno dei tasti **SU**  / **GIÙ**  per evidenziare la voce **AUTO BACKLIGHT** e premere il tasto **INVIO**  subito dopo.
2. Appare ora l'omonima schermata.
3. Utilizzare uno dei tasti **SU**  / **GIÙ**  per evidenziare la voce **ENABLE** (ATTIVA, impostazione di fabbrica) o **DISABLE** (DISATTIVA).
4. Premere il tasto **INVIO**  per accettare la selezione e uscire sul menu delle impostazioni.

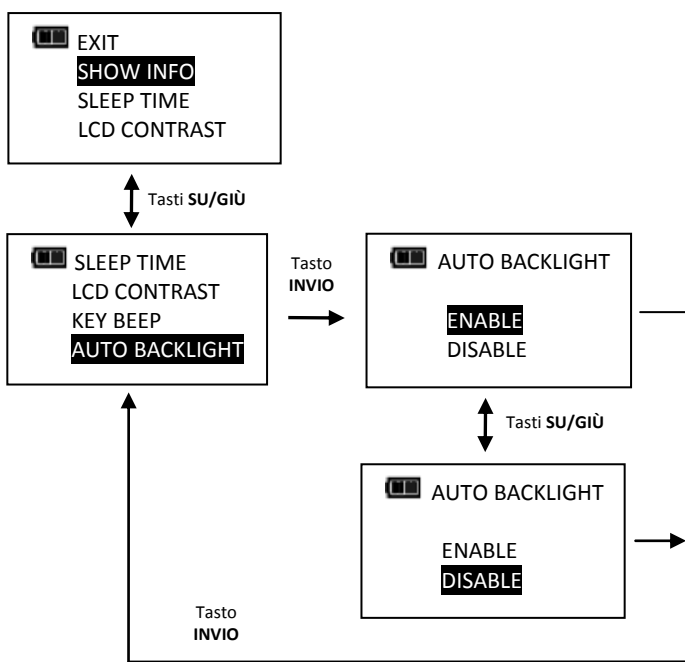

### Impostazione per l'accensione/spegnimento della retroilluminazione

Tramite questa funzione è possibile alternare l'attivazione o la disattivazione delle modalità di accensione della retroilluminazione. Quando la modalità alternata è disattivata, il tasto **RETROILLUMINAZIONE** accende la retroilluminazione e la spegne automaticamente dopo cinque secondi dall'ultima pressione su un tasto. Quando invece la modalità alternata è attivata, il tasto **RETROILLUMINAZIONE** illumina lo schermo e lo lascia illuminato fino a quando non viene premuto nuovamente il tasto **RETROILLUMINAZIONE** .

1. Dal menu impostazioni, premere uno dei tasti **SU** / **GIÙ** per evidenziare la voce **TOGGLE BACKLGH** e premere il tasto **INVIO** subito dopo.
2. Appare ora l'omonima schermata.
3. Utilizzare uno dei tasti **SU** / **GIÙ** per evidenziare la voce **ENABLE** (ATTIVA) o **DISABLE** (DISATTIVA, impostazione di fabbrica).
4. Premere il tasto **INVIO** per accettare la selezione e uscire sul menu delle impostazioni.

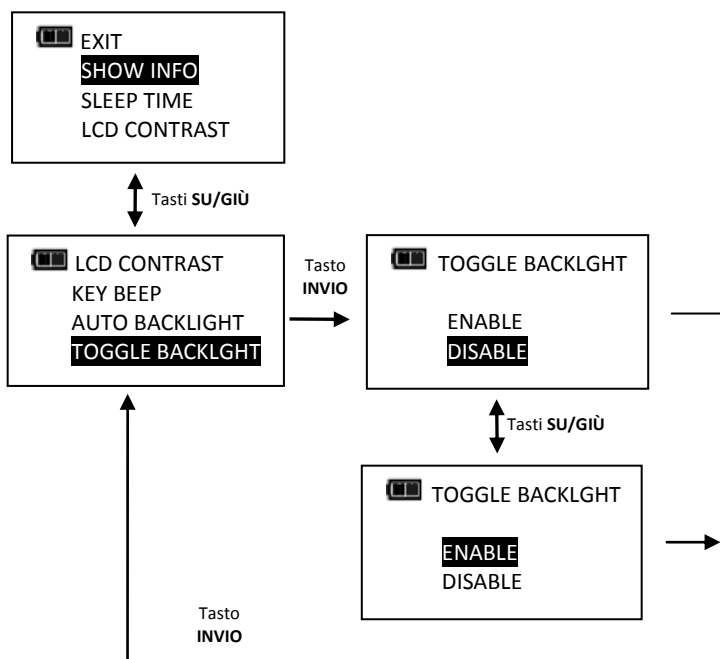

*Nota:* la retroilluminazione dello schermo si spegne anche allo spegnimento della chiave quando si preme il tasto **ALIMENTAZIONE** oppure quando l'utensile rimane inattivo per un certo intervallo.

*Nota:* quando la modalità alternata di retroilluminazione è attivata e lo schermo è illuminato, la retroilluminazione rimane accesa durante e dopo la procedura di serraggio.

## Configurazione del movimento di vibrazione

Tramite questa funzione è possibile configurare il movimento di vibrazione su On o Off per scegliere se avvisare l'utente quando è stato raggiunto il valore target di serraggio oppure se si preferisce risparmiare le batterie.

1. Dal menu delle impostazioni, premere uno dei tasti **SU ▲** / **GIÙ ▼** per evidenziare la voce **VIBRATOR CONFIG** e premere il tasto **INVIO ↵** subito dopo.
2. Appare ora l'omonima schermata.
3. Utilizzare uno dei tasti **SU ▲** / **GIÙ ▼** per alternare la selezione sulla voce ON o OFF.
4. Premere il tasto **INVIO ↵** per accettare la selezione e uscire sul menu delle impostazioni.

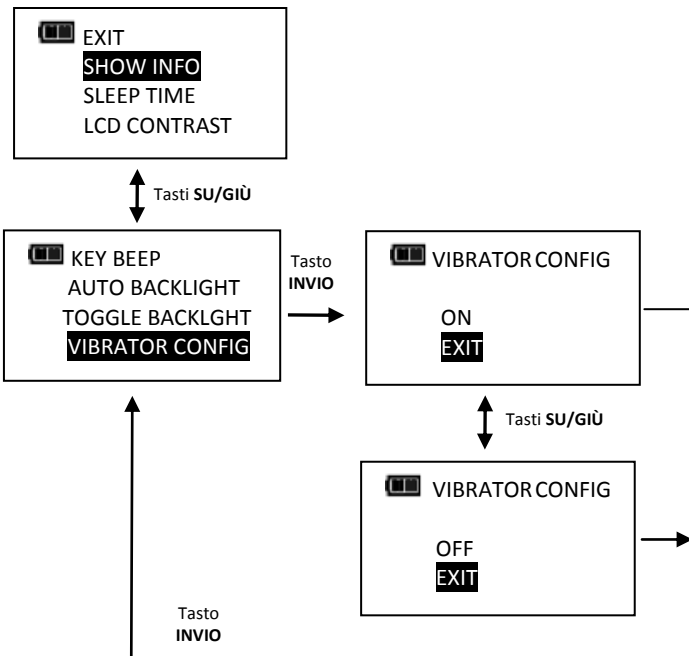

## • Configurazioni avanzate

### Accesso alle configurazioni avanzate

Al menu per le configurazioni avanzate si accede tramite la voce **CONFIGURE** nel menu principale.

1. Dalla schermata valore target della coppia o dell'angolo, premere il tasto **INVIO ↵** per 3 secondi.
2. Evidenziare la voce **CONFIGURE** nel menu utilizzando i tasti **SU ▲** / **GIÙ ▼**.
3. Premere il tasto **INVIO ↵** per visualizzare la schermata delle configurazioni.

Voci del menu:



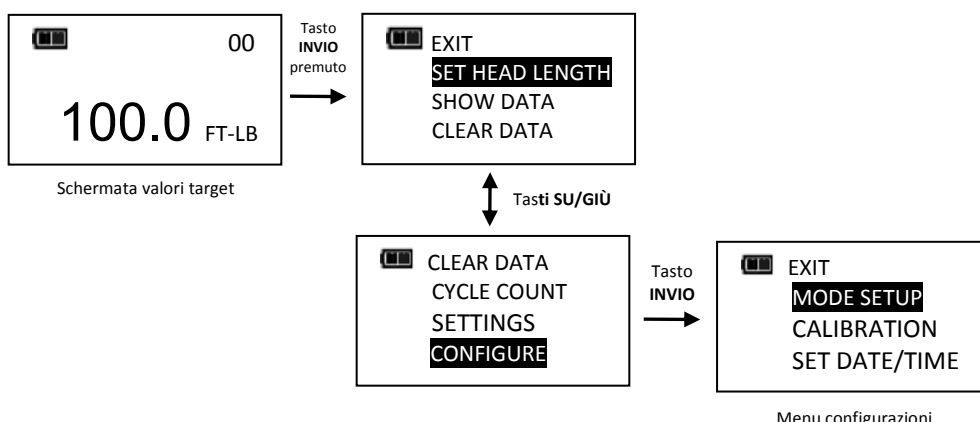

- EXIT - Esce dal menu delle configurazioni e ritorna alla schermata dei valori target della coppia o dell'angolo.
  - MODE SETUP - Visualizza il menu d'impostazione delle modalità della chiave.
  - CALIBRATION - Visualizza il menu di calibrazione della chiave (protetto da una password).
  - SET DATE/TIME - Visualizza la schermata per l'impostazione della data e dell'ora.
  - SET CAL INTRVAL - Visualizza la schermata per l'impostazione dell'intervallo di calibrazione (è necessario regolare la data e l'ora).
4. Per uscire dal menu delle configurazioni e ritornare alla schermata del valore target della coppia o dell'angolo, premere il tasto **INVIO ↵** quando è evidenziata la voce **EXIT** sul menu.



*Nota: tutte le impostazioni configurabili dall'utente sono memorizzate su un supporto non-volatile in modo da essere mantenute anche quando la chiave è spenta.*

## Impostazione modalità





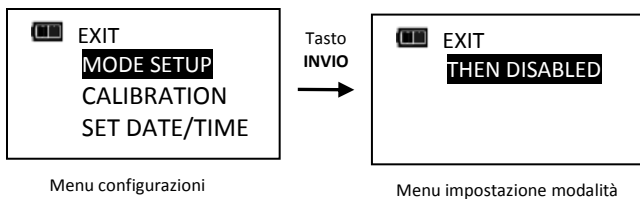

Tramite questo menu è possibile attivare/disattivare la modalità coppia POI quella angolo.

1. Dal menu delle configurazioni, premere il tasto **INVIO**  quando è evidenziata la voce **MODE SETUP**.
2. Appare ora l'omonima schermata.  
Voci del menu:
  - EXIT - Esce dal menu dell'impostazione modalità e ritorna alla schermata configurazioni.
  - THEN DISABLED - Visualizza la schermata per attivare/disattivare la modalità THEN (POI).
3. Utilizzare uno dei tasti **SU** /**GIÙ**  per evidenziare la voce desiderata.
4. Premere il tasto **INVIO**  quando è evidenziata la voce **EXIT** sul menu per ritornare al menu configurazioni.



## Attivazione/Disattivazione della modalità Torque THEN Angle

Tramite questa funzione è possibile attivare o disattivare la modalità Torque THEN (coppia POI).



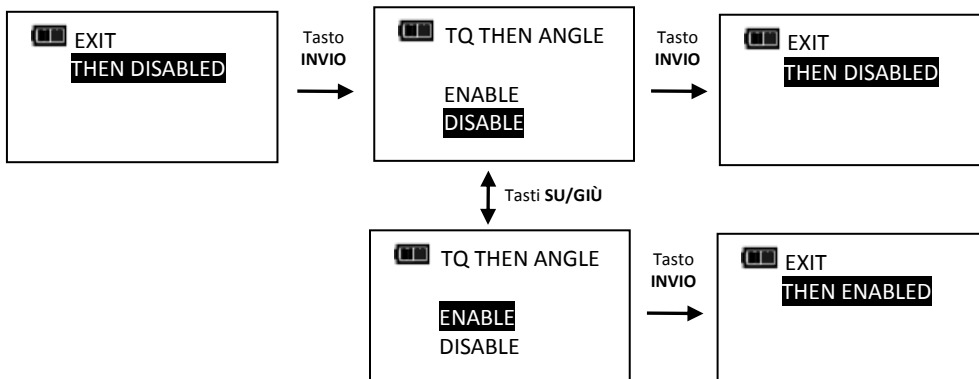



1. Dal menu dell'impostazione modalità, premere uno dei tasti **SU** /**GIÙ**  per evidenziare la voce **THEN DISABLED** (impostazione di fabbrica) e premere il tasto **INVIO**  subito dopo.
2. Appare ora la schermata per attivare/disattivare la modalità TQ THEN ANGLE (coppia poi angolo).
3. Utilizzare uno dei tasti **SU** /**GIÙ**  per evidenziare la voce **ENABLE** (ATTIVA) o **DISABLE** (DISATTIVA).
4. Premere il tasto **INVIO**  per accettare la selezione e uscire sul menu dell'impostazione modalità.



*Nota: la selezione sul menu indica la configurazione attuale (ENABLED o DISABLED, attivata o disattivata).*

## Modalità Torque THEN Angle

Prima di selezionare e impostare la modalità Torque THEN Angle (coppia POI angolo), bisogna impostare un valore target per la coppia con le unità e un valore target dell'angolo. In questa modalità, quando la forza di serraggio raggiunge il valore target della coppia, la chiave passa automaticamente in modalità angolo per la relativa misurazione. Le spie di progressione indicano l'avanzamento della coppia di serraggio applicata mentre quest'ultima viene misurata oppure dell'angolo quando è quest'ultimo ad essere misurato.

1. Dalla schermata valore target della coppia, utilizzare uno dei tasti **SU** /**GIÙ**  per impostare il valore target della coppia e il tasto **UNITÀ** **U** per selezionare l'unità di misurazione e premere il tasto **INVIO**  subito dopo.
2. Appare ora l'omonima schermata. Utilizzare uno dei tasti **SU** /**GIÙ**  per impostare il valore target dell'angolo e premere il tasto **INVIO**  subito dopo.

3. Appare ora la schermata per la modalità Torque THEN Angle (coppia POI angolo).
4. Serrare la vite fino a raggiungere il valore target della coppia e girare la chiave sul valore target dell'angolo.

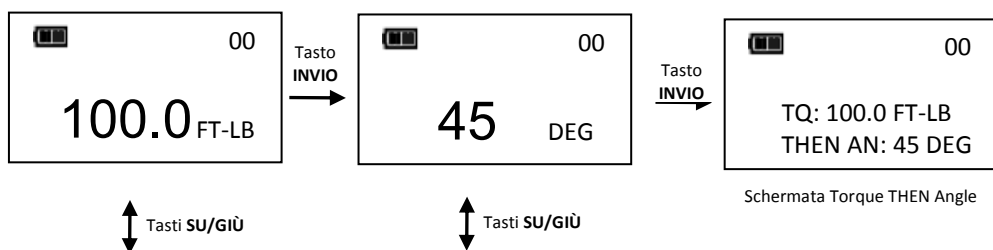

*Nota:* dalla schermata Torque THEN Angle, è possibile utilizzare il tasto **UNITÀ U** per selezionare l'unità di misura per la coppia.

*Nota:* per impostare le preimpostazioni per la modalità Torque THEN Angle basta tenere premuto il tasto Unità quando all'interno dell'omonima schermata. Consultare la sezione "Aggiunta di un valore preimpostato di coppia" e quella "Aggiunta di un valore preimpostato di angolo" per i criteri sui parametri da inserire.

*Nota:* il ciclo di coppia viene registrato in memoria solo quando vengono raggiunti insieme i valori target della coppia e dell'angolo.

*Nota:* le spie di progressione rosse e gialle si accendono quando la coppia supera il 110% su tutta la scala della portata della chiave oppure l'angolo supera il valore target del 4% in modalità manuale.

*Nota:* le spie di progressione rosse e gialle si accendono quando la coppia o l'angolo supera il suo valore massimo in modalità preimpostazione.

### **Calibrazione**

Il menu per la calibrazione è protetto da una password. Contattare il centro Snap-on autorizzato più vicino per informazioni sull'accesso a questo menu.

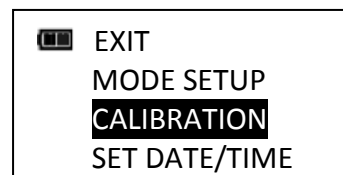

### **Impostazione della data e dell'ora**

Tramite questa funzione è possibile impostare la data e l'ora in modo da avere informazioni precise per quello che riguarda i dati cronologici in memoria, quelli sull'ultima calibrazione e sulla relativa scadenza.

*Nota:* la data e l'ora impostati per la prima volta coincideranno con la data di messa in uso e quella di decorrenza per il calcolo dell'intervallo di calibrazione (vedere "Impostazione dell'intervallo di calibrazione" nella sezione Configurazioni avanzate).

1. Dal menu delle impostazioni, premere uno dei tasti **SU ▲/GIÙ ▼** per evidenziare la voce **SET DATE/TIME** e premere il tasto **INVIO ↵** subito dopo.
2. Appare ora la schermata per l'impostazione della data con evidenziato l'anno.
3. Utilizzare uno dei tasti **SU ▲/GIÙ ▼** per selezionare l'anno e premere il tasto **INVIO ↵** per evidenziare il mese.
4. Utilizzare uno dei tasti **SU ▲/GIÙ ▼** per selezionare il mese e premere il tasto **INVIO ↵** per evidenziare il giorno.
5. Utilizzare uno dei tasti **SU ▲/GIÙ ▼** per selezionare il giorno e premere il tasto **INVIO ↵**.
6. Appare ora la schermata per l'impostazione dell'orario con evidenziata l'ora.
7. Utilizzare uno dei tasti **SU ▲/GIÙ ▼** per selezionare l'ora e premere il tasto **INVIO ↵** per evidenziare i minuti.
8. Utilizzare uno dei tasti **SU ▲/GIÙ ▼** per selezionare i minuti e premere il tasto **INVIO ↵** per evidenziare i secondi.
9. Utilizzare uno dei tasti **SU ▲/GIÙ ▼** per selezionare i secondi e premere il tasto **INVIO ↵**.



10. L'orologio è così impostato e appare ora il menu di configurazione.

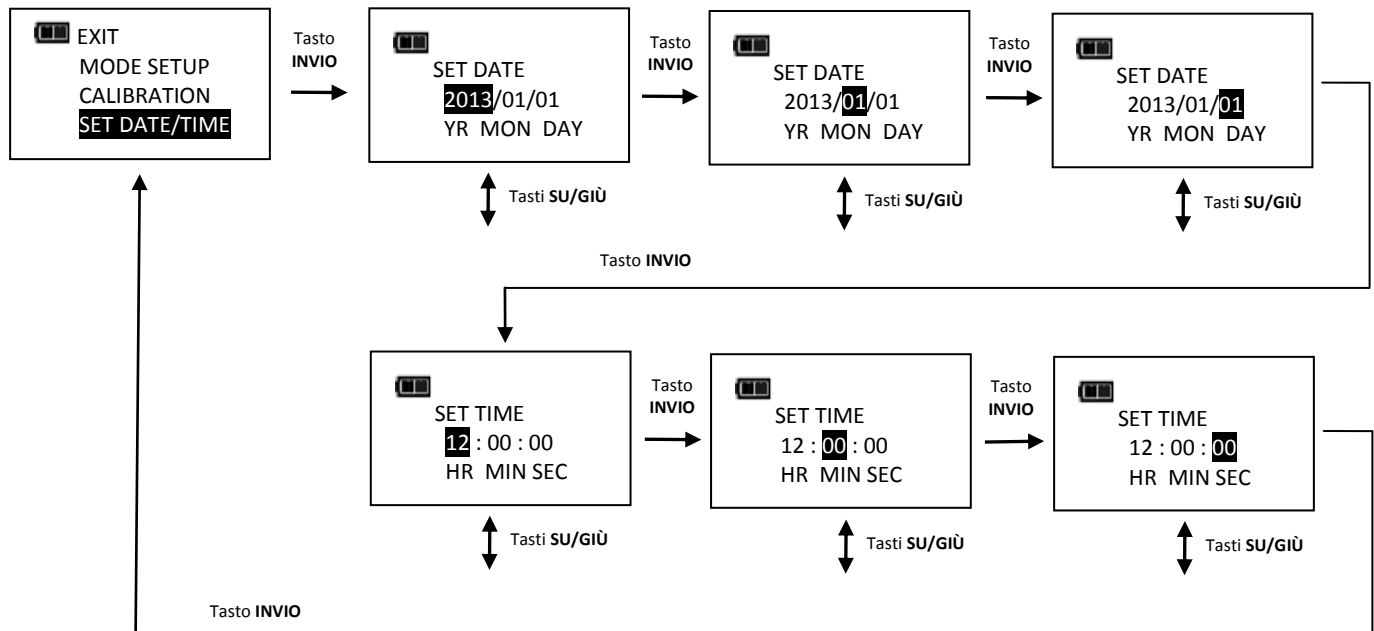

*Nota: la selezione dell'anno parte dal 2013 in poi. La selezione del mese va da 1 a 12. La selezione del giorno da 1 a 31.*

*Nota: la selezione dell'ora va da 0 a 23. La selezione dei minuti e dei secondi va da 0 a 59.*

*Nota: togliendo le batterie per più di 20 minuti, l'orologio si resetta sui valori di fabbrica e bisognerà reimpostare tutti i dati al momento dell'accensione della chiave.*

### Impostazione dell'intervallo di calibrazione

Tramite questa funzione è possibile impostare un intervallo alla cui scadenza verrà visualizzato il messaggio "CAL NEEDED" ad indicare che bisogna ripetere la calibrazione.

1. Dal menu delle impostazioni, premere uno dei tasti **SU ▲/GIÙ ▼** per evidenziare la voce **SET CAL INTRVAL** e premere il tasto **INVIO ↵** subito dopo.
2. Appare ora l'omonima schermata.
3. Utilizzare uno dei tasti **SU ▲/GIÙ ▼** per cambiare l'intervallo di calibrazione.

Intervalli selezionabili:

- DISABLED (disattivato, impostazione di fabbrica)
- 3 MON (3 mesi)
- 6 MON (6 mesi)
- 12 MON (12 mesi)

4. Premere il tasto **INVIO ↵** per accettare la selezione e uscire sul menu delle configurazioni.

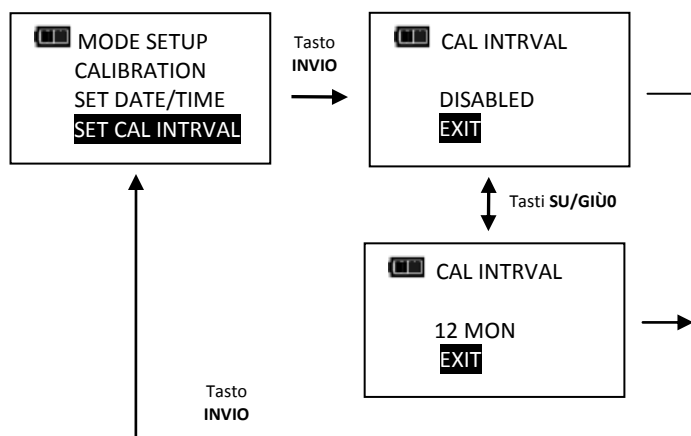

*Nota: prima di poter impostare l'intervallo di calibrazione, bisogna impostare la data e l'ora. Togliendo le batterie per più di 20 minuti, l'orologio si resetta sui valori di fabbrica e bisognerà reimpostare tutti i dati al momento dell'accensione della chiave.*







*Nota: l'intervallo di calibrazione viene calcolato a decorrere dalla data di messa in uso o da quella dell'ultima calibrazione (vedere il menu SHOW INFO) a seconda di quella più recente. Quando la data sull'orologio è posteriore a quella di messa in uso o a quella dell'ultima calibrazione,*





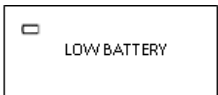

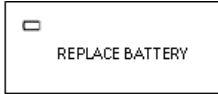

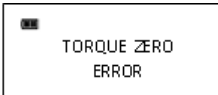
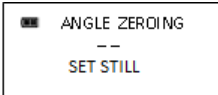
sullo schermo appare il messaggio "CAL NEEDED" al momento dell'accensione o quando si riazzera la chiave. Premendo il tasto **INVIO**  si passa al menu per i valori target. Procedendo con il serraggio della vite con il messaggio "CAL NEEDED" sullo schermo, la chiave procederà immediatamente alla misurazione della coppia o dell'angolo e ritornerà al menu con i valori target a ciclo concluso.

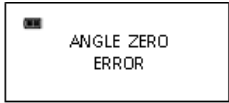
**Nota:** come alternativa alla funzione intervallo di calibrazione, nel menu di calibrazione è disponibile un contatore dei cicli di calibrazione (contattare il centro Snap-on più vicino per informazioni in merito).

## • Risoluzione di problemi

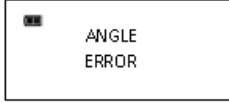
**Nota:** qualora uno dei seguenti problemi perdurasse, portare la chiave a un centro Snap-on autorizzato per la riparazione.

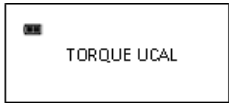
Problema	Probabile diagnosi	Soluzione
La chiave non si accende quando si preme il tasto <b>ALIMENTAZIONE</b> 	Batterie scariche/mancanti	Sostituire le batterie
	Comportamento anomalo del software	Spegnere e riaccendere dal coperchio
Letture della coppia fuori specifica	Bisogna effettuare la calibrazione	Ricalibrare
	È stata indicata una lunghezza della testa errata	Indicare il fattore di correzione della lunghezza della testa esatto
La chiave non ha mantenuto le impostazioni quando sono state estratte le batterie	Le batterie sono state estratte prima del salvataggio delle impostazioni sulla memoria non-volatile	Re-inserire le impostazioni e premere e mantenere premuto il tasto <b>ALIMENTAZIONE</b>  per spegnere la chiave prima di rimuovere le batterie
Viene visualizzato il valore di coppia o dell'angolo quando la chiave non è in tiro	Il valore di coppia o dell'angolo è stato azzerato quando la chiave era in tiro	Mettere la chiave su una superficie stabile senza che sia in tiro e premere il tasto <b>ALIMENTAZIONE</b>  per azzerarla
	Batterie quasi scariche	Premere il tasto <b>INVIO</b>  per continuare a usare la chiave e sostituire le batterie al più presto
	Batterie scariche	Premere il tasto <b>ALIMENTAZIONE</b>  per spegnere la chiave e sostituire le batterie
	La chiave era in tiro quando è stato effettuato l'azzeramento	Rilasciare il tiro della chiave e riazzere
	Il serraggio ha superato i limiti di coppia	Ricalibrare
	La chiave è stata calibrata erroneamente	Ricalibrare
	Guasto al sensore di coppia	Portare la chiave a un centro Snap-on per la riparazione
	La chiave è stata mossa durante l'azzeramento	Mettere la chiave su una superficie stabile
	Sensore giroscopico instabile	Portare la chiave a un centro Snap-on per la riparazione

Problema	Probabile diagnosi	Soluzione
	È stato premuto il tasto <b>ALIMENTAZIONE</b>  durante l'azzeramento dell'angolo (l'azzeramento è stato interrotto per accedere ai menu)	Mettere la chiave su una superficie stabile e premere il tasto <b>ALIMENTAZIONE</b>  per azzerarla
	È stata applicata una coppia di serraggio superiore al 125% su tutta la scala	Spegnere e riaccendere la chiave usando il tasto <b>ALIMENTAZIONE</b>  e ricalibrare
	La chiave è stata ruotata troppo velocemente durante la misurazione dell'angolo	Mettere la chiave su una superficie stabile e premere il tasto <b>ALIMENTAZIONE</b>  per azzerarla
	Guasto alla memoria	Cancellare i dati in memoria
	Coppia non calibrata	Calibrare la coppia
	Angolo non calibrato	Calibrare l'angolo

## ● USO DI RIDUTTORI, PROLUNGHE E DI ACCESSORI UNIVERSALI

Ogni volta che con una chiave dinamometrica si utilizza un riduttore, una prolunga o un accessorio universale tale da alterare la distanza tra l'attacco quadro e la vite calcolata durante la calibrazione, bisognerà correggere la lunghezza della testa per mantenere una lettura accurata della coppia.

Utilizzando una prolunga instabile o un accessorio universale, come fattore di correzione (offset) dall'attacco perpendicolare non superare i 15 gradi. Non utilizzare prolunghe lunghe con attacchi flessibili alla flessione completa.

## ● CALIBRAZIONE

**Contattare un agente di vendita della Snap-on per i servizi di calibrazione.**

## ● OMOLOGAZIONE

Questa chiave TechAngle® è stata calibrata in fabbrica utilizzando strumenti di dislocazione angolare e di misurazione della coppia conformi agli standard N.I.S.T. (National Institute of Standards and Technology). I parametri di coppia sono conformi alle norme ISO 6789-2003 e ASME B107-28-2010. Nota: per le chiavi angolari esistono anche Standard internazionali e normative non U.S.A.

**IMPORTANTE!** Gli interventi di calibrazione sono registrati nella memoria della chiave e fungono da prova per i casi di decadenza dell'omologazione di fabbrica.

## ● MANUTENZIONE / CURA

Pulire la chiave passandoci sopra un panno umido. **NON** utilizzare solventi, diluenti o detersivi per carburatori.

**NON** immergerla in nessun tipo di liquido.

Gli interventi di manutenzione, riparazione e calibrazione devono essere effettuati esclusivamente nei centri autorizzati Snap-on. Contattare l'agente della Snap-on Tools più vicino.

La riparazione del cricchetto in testa alla chiave può essere effettuata da un tecnico Snap-on o dall'utente.

## ● Sostituzione delle batterie

**Per la loro sostituzione, utilizzare esclusivamente tre batterie di tipo "AA".**

- Non tentare di ricaricare le celle delle batterie alcaline.
- Non usare insieme batterie di tipo diverso.
- Sostituire tutte le batterie contemporaneamente.
- Conservare sempre la chiave in un luogo asciutto.
- Estrarre sempre le batterie quando si conserva una chiave per un periodo di inutilizzo superiore a tre mesi.

*Nota: durante la sostituzione delle batterie, le impostazioni data/ora vengono mantenute per 20 minuti.*

*Nota: svitare il coperchio delle batterie in senso antiorario.*

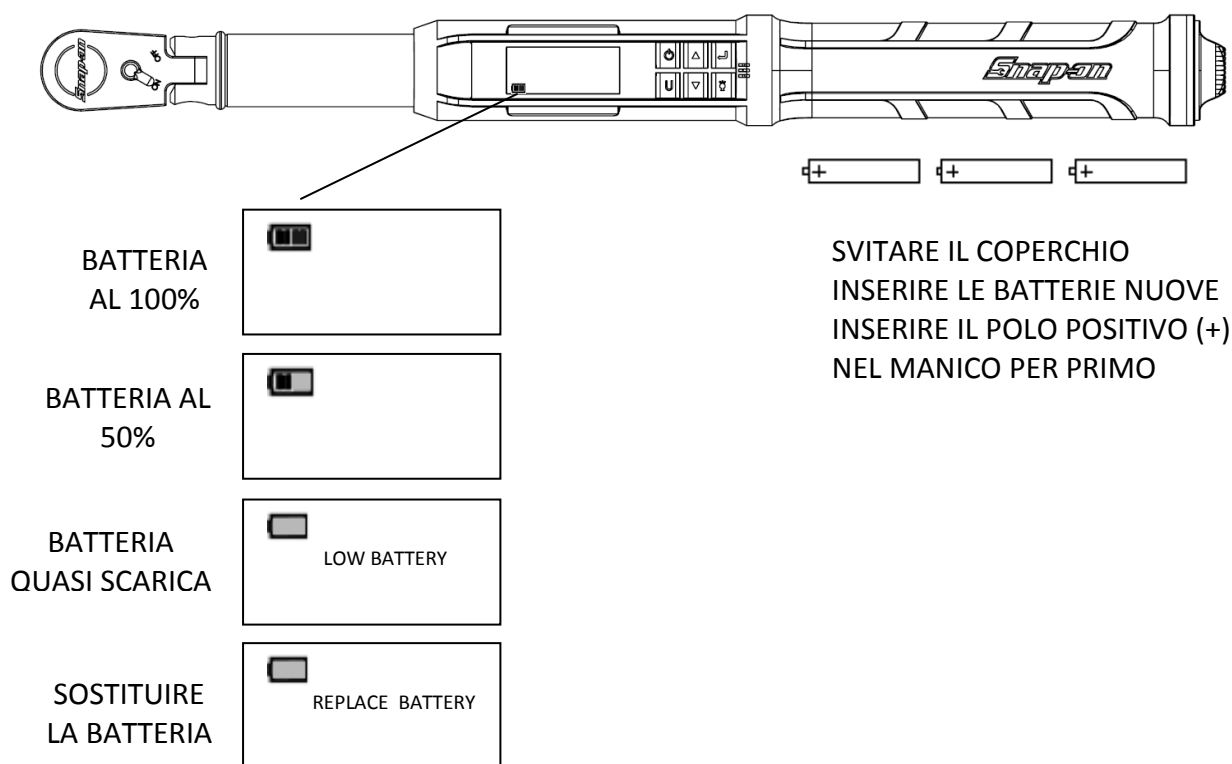

*Nota: quando appare il messaggio "Replace Battery" sullo schermo, la chiave non funziona fino a quando non si sostituiscono le batterie. Funziona solo il tasto **ALIMENTAZIONE**  per spegnere immediatamente la chiave.*

## ● Indicatori di memoria

DATI IN  
MEMORIA

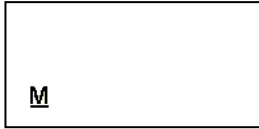

In memoria ci sono meno di 50 cicli di coppia e angolo.

MEMORIA  
PIENA

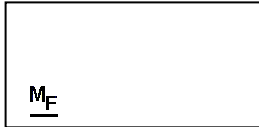

In memoria ci sono 50 cicli di coppia e angolo. Il ciclo più vecchio verrà sostituito da quello più recente.

ERRORE DI  
MEMORIA



Errore di lettura o scrittura in memoria. Rivolgersi a un centro Snap-on autorizzato per la riparazione dopo aver cancellato tutti i dati.

# CENTRI DI RIPARAZIONE SNAP-ON AUTORIZZATI

## USA

**Eastern Repair Center**  
6320 Flank Drive  
Harrisburg, PA 17112  
Telefono: 717-652-7914  
Fax: 717-652-7123

**Northern Repair Center**  
3011 E. State Rt. 176, Dock A  
Crystal Lake, IL 60014  
Telefono: 815-479-6850  
Fax: 815-479-6857

**Western Repair Center**  
2151 Challenger Way  
Carson City, NV 89706-0753  
Telefono: 775-883-8585  
Fax: 775-883-8590

## CANADA

**Western Repair Center**  
7403-48 Street SE  
Calgary, Alberta  
Canada, T2C-4H6  
Telefono: 403-720-0525  
Fax: 403-720-0524

## INTERNAZIONALI

**United Kingdom Repair Center**  
Telford Way  
Telford Way Industrial Estate  
Kettering, Northants  
NN16 8UN England  
Telefono: 44-1-536-413855  
Fax: 44-1-536-413900

**Australia Repair Centre**  
Snap-on Tools Australia PTY.LTD  
Unit 6/110 Station Road  
Seven Hills, NSW 2147  
Australia  
Telefono: 61-2-8937-9155  
Fax: 61-2-9624-2445

**Singapore Repair Center**  
Snap-on Tools Singapore PTE Ltd  
128 Tagore Lane, Blk 4 Singapore  
787554 Republic of Singapore  
Telefono: 011-65-451-5570  
Fax: 011-65-451-5574

**Japan Repair Center**  
Snap-on Tools Japan K.K.  
3-5-12 Konan  
Minato-KU, Tokyo 108  
Japan  
Telefono: 81-3-5463-1280  
Fax: 81-3-5463-1284

**Snap-on/SUN De Mexico**  
S.A. De C.V.  
Avenida Presidente Juarez No.  
2016  
Col Los Reyes Zona Industrial  
Tlalnepantla Edo De Mexico  
CP54070 MEXICO  
Telefono: 52-55-53903122  
Fax: 52-55-53903259

### NOTE IMPORTANTI SULL'IMPATTO AMBIENTALE:

1.  
2.



3. QUESTO UTENSILE POTREBBE  
CONTENERE MATERIALI PERICOLOSI E  
POTENZIALMENTE NOCIVI PER  
L'AMBIENTE.

4. NON GETTARE QUESTO UTENSILE IN  
UNA DISCARICA PUBBLICA.  
CONSEGNARLO INVECE AL  
DISTRIBUTORE O A UN CENTRO DI  
RACCOLTA DIFFERENZIATA.

GRAZIE PER LA VOSTRA COLLABORAZIONE PER IL RISPETTO  
DELL'AMBIENTE!

**Snap-on Tools Company**  
Kenosha, WI 53141-1410 USA



Stampato negli USA

## EC DECLARATION OF CONFORMITY

Manufacturer:  
**Snap-on Specialty Tools**  
19220 San Jose AVENUE  
City of Industry, CA 91748



Series: A-TECH Series  
Type: Type II, Class B Electronic Torque Wrench  
Model No: ATECH1FR240B / ATECH2FR100B / ATECH3FR250B

These products are in conformity with the provisions of the following EC directives when installed in accordance with the installation instructions contained in the product documentation.

2004/108/EC Test Report # 3325 - EMC Directive

---

And that the standards referenced below have been applied:

EN 61326-1:2006	Electrical equipment for measurement, control and laboratory use. EMC requirements. General requirements.
Cispr 11 ed. 5.1 :2010	Industrial, scientific and medical equipment. Radio-frequency disturbance characteristics. Limits and methods of measurement. Radiated Emissions.
EN 61000-4-2:2008-12	Electromagnetic compatibility (EMC) - Part 4-2: Testing and measurement techniques – Electrostatic discharge immunity test.
EN 61000-4-3 ed. 3-2: 2010-04	Electromagnetic compatibility (EMC) - Part 4-3: Testing and measurement techniques – Radiated, radio-frequency, electromagnetic field immunity test
EN 61000-4-8: 2009-09	Electromagnetic compatibility (EMC) – Part 4-8: Testing and measurement techniques – Power frequency magnetic field immunity test

---

Company Authorized to Compile the Technical File:

**Snap-on Tools Company**  
2801 80<sup>th</sup> Street  
Kenosha, WI 53141-1410, U.S.A.

The authorized representative located within the community is:

**Matthew Law**  
**Snap-on Tools LTD.**  
Telford Way Industrial Estate  
Kettering, Northants  
NN16 8SN  
United Kingdom

Signature: \_\_\_\_\_

  
**Director, Engineering: Nathan Lee**  
**Snap-on Specialty Tools**  
19220 San Jose AVENUE  
City of Industry CA, 91748  
June 2013

# **AUTHORIZED SNAP-ON REPAIR CENTERS**

## **USA**

### **Eastern Repair Center**

6320 Flank Drive  
Harrisburg, PA 17112  
Phone: 717-652-7914  
Fax: 717-652-7123

### **Northern Repair Center**

3011 E. State Rt. 176, Dock A  
Crystal Lake, IL 60014  
Phone: 815-479-6850  
Fax: 815-479-6857

### **Western Repair Center**

2151 Challenger Way  
Carson City, NV 89706-0753  
Phone: 775-883-8585  
Fax: 775-883-8590

## **CANADA**

### **Western Repair Centre**

7403-48 Street SE  
Calgary, Alberta  
Canada, T2C-4H6  
Phone: 403-720-0525  
Fax: 403-720-0524

## **INTERNATIONAL**

### **United Kingdom Repair Center**

Telford Way  
Telford Way Industrial Estate  
Kettering, Northants  
NN16 8UN England  
Phone: 44-1-536-413855  
Fax: 44-1-536-413900

### **Australia Repair Centre**

Snap-on Tools Australia PTY.LTD  
Unit 6/110 Station Road  
Seven Hills, NSW 2147  
Australia  
Phone: 61-2-8937-9155  
Fax: 61-2-9624-2445

### **Singapore Repair Center**

Snap-on Tools Singapore PTE Ltd  
128 Tagore Lane, Blk 4 Singapore  
787554 Republic of Singapore  
Phone: 011-65-451-5570  
Fax: 011-65-451-5574

### **Japan Repair Center**

Snap-on Tools Japan K.K.  
3-5-12 Konan  
Minato-KU, Tokyo 108  
Japan  
Phone: 81-3-5463-1280  
Fax: 81-3-5463-1284

### **Snap-on/SUN De Mexico**

S.A. De C.V.  
Avenida Presidente Juarez No. 2016  
Col Los Reyes Zona Industrial  
Tlalnepantla Edo De Mexico  
CP54070 MEXICO  
Phone: 52-55-53903122  
Fax: 52-55-53903259

#### **IMPORTANT ENVIRONMENTAL NOTES:**



1. THIS EQUIPMENT MAY CONTAIN HAZARDOUS MATERIALS WHICH CAN BE HARMFUL TO THE ENVIRONMENT.
2. DO NOT DISPOSE OF THIS EQUIPMENT AS MUNICIPAL WASTE. RETURN IT TO DISTRIBUTOR OR A DESIGNATED COLLECTION CENTER.

**THANK YOU FOR CARING ABOUT OUR ENVIRONMENT!**

## **Snap-on Tools Company**

Kenosha, WI 53141-1410 USA



**Printed in USA**  
14-05